

**MODEL 9933  
9934**

**UTILITY SHELF**

- Model 9933 – 4 Hooks/3 Holders **Bradex™**
- Model 9934 – 5 Hooks/4 Holders **Bradex™**

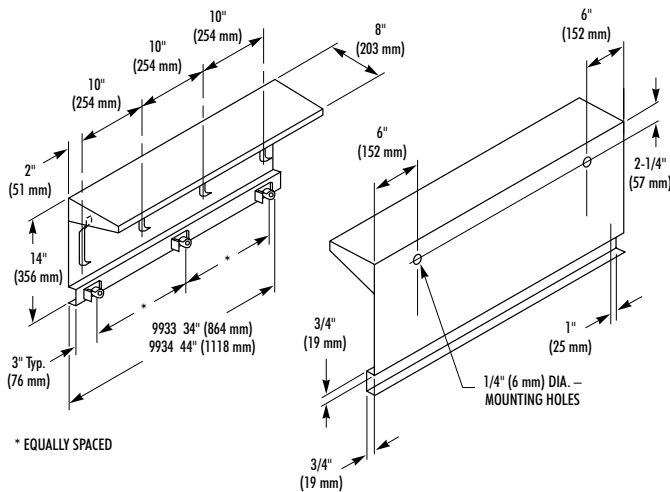
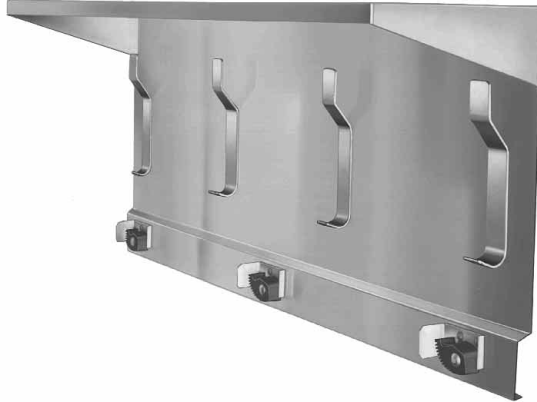

**CONSTRUCTION:**

- **SHELF AND BRACKET** fabricated of type 304 (18-8), 18 gauge stainless steel with exposed surfaces in architectural satin finish.
- **GUSSETS AND HOOKS** fabricated of type 304 (18-8), 16 gauge stainless steel with exposed surfaces in architectural satin finish.
- **HOLDERS** consist of spring activated rubber cams on plated steel retainers.

**OPERATION:**

Weight of mop or broom holds handle in place.

**INSTALLATION:**

Secure to wall with mounting screws (included) at holes provided.

**GUIDE SPECIFICATION:**

Surface mounted utility shelf shall be fabricated of type 304 (18-8), 18 gauge stainless steel in satin finish. Hooks shall be of 16 gauge stainless steel. Holders shall be with spring activated rubber cams.

Surface Mounted Utility Shelf shall be Bradley Model 9933 (9934).