

SOAP DISPENSER

- Recess Mounted
- Model 645 – Powdered Soap **Bradex™**

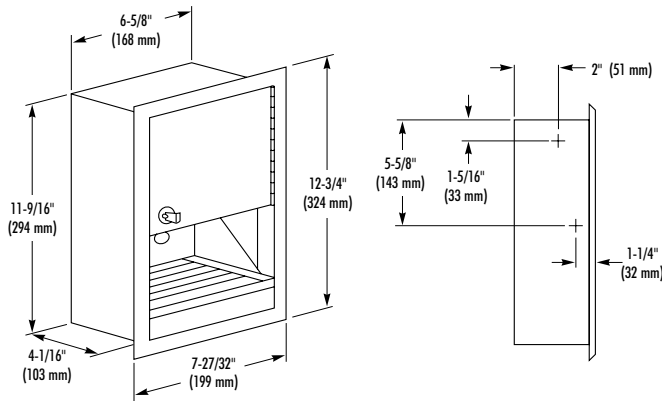

CONSTRUCTION:

- **FLANGE** fabricated of type 304 (18-8), 22 gauge stainless steel with exposed surfaces in architectural satin finish. One piece seamless construction, 3/4" wide with beveled edges.
- **CABINET** fabricated of type 304 (18-8), heavy gauge stainless steel with exposed surfaces in architectural satin finish.
- **DRIP TRAY** fabricated of type 304 (18-8), heavy gauge stainless steel with exposed surfaces in architectural satin finish.
- **SOAP DISPENSER** is die-cast zinc, heavy chrome plated.

CAPACITY:

40 oz. powdered soap.

OPERATION:

Soap dispenser is mounted on back of door and fills from top. Powdered soap is dispensed by pushing plunger up. Slotted base and waste tray are removable.

INSTALLATION:

Requires rough wall opening 7-1/8"W x 12-1/6"H x 4-9/16"D. Secure to framing with mounting screws (included) at holes provided. Shim at screw points as required.

GUIDE SPECIFICATION:

Recessed powdered soap dispenser shall be fabricated of type 304 stainless steel with exposed surfaces in satin finish. Base and waste tray shall be removable for cleaning. Capacity: 40 oz. powdered soap.

Overall dimensions: 7-27/32"W x 12-3/4"H x 4-1/16"D.

Recessed Powdered Soap Dispenser shall be Bradley Model 645.