

HAND/HAIR DRYER

- Surface Mounted
- Model 2877-28 **Bradex™**
Hand Dryer-Chrome Plated
- Model 2887-28 – Hand Dryer-Color
(Specify color _____)
- Model 2878-28
Hair Dryer-Chrome Plated
- Model 2888-28 – Hair Dryer-Color
(Specify color _____)

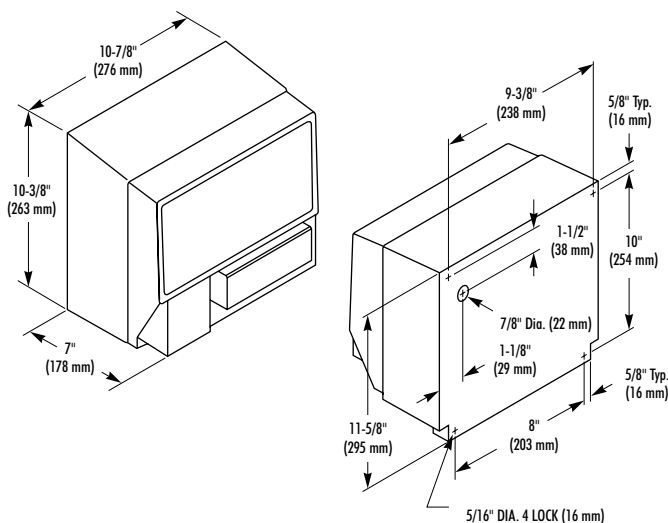

MODEL 2877-28/2887-28 2878-28/2888-28

CONSTRUCTION:

- **COVER, NOZZLE AND PUSHBUTTON:** Fabricated of rust and corrosion free diecast zinc with satined chrome over nickel finish.
- **MOTOR:** PSC induction motor (brushless), 1/10 HP, thermally protected, self aligning quiet bearings, resilient ring motor mounts; no field lubrication required. 120 volt, 17 amp, 60 hz standard.
- **HEATING ELEMENT:** 2000 watt nickel chromium heating element blower, inlet mounted (inaccessible through nozzle), protected by self resetting disc thermostat.
- **SWITCH TIMER:** 25 ampere rating, enclosed switch. 30 second timer Model 2877/2887; 80 second timer Model 2878/2888; all timers are impedance protected.
- **BLOWER:** Operates at 3450 RPM delivering 100 CFM at 130 deg. F. and average velocity of 5000 LFM.
- **BASE PLATE:** Diecast aluminum.
- **AIR INLET:** Integrally cast in cover.
- **COVER LOCKING:** 1/4 inch diameter socket head safety screws; special wrench provided.
- **ENTIRE UNIT:** Is U.L. listed and guaranteed against defects in material and/or workmanship for ten (10) years.

OPERATION:

Press button and release to activate dryer.

INSTALLATION:

Secure base plate to wall with four 1/4" dia. fasteners suitable to the wall construction. Base knockouts allow either rear or front wiring. Connect electrical service to terminal board per cover mounted wiring diagram. Attach cover to base before energizing dryer at breaker panel.

OPTIONAL FEATURES:

Feature	Suffix
<input type="checkbox"/> 208 Volt 10 amp, 60 hz	-29
<input type="checkbox"/> 240 Volt 8.5 amp, 60 hz	-53
<input type="checkbox"/> White epoxy finish	-33
<input type="checkbox"/> 220 Volt 7.5 amp, 50 hz	-48
<input type="checkbox"/> 240 Volt 7 amp, 50 hz	-49

GUIDE SPECIFICATION:

Surface mounted hand (hair) dryer cover shall be fabricated of rust and corrosion free diecast zinc with fixed nozzle. Motor of PSC induction type with self aligning, self lubricating, quiet bearings; thermally protected. Automatic reset thermostat protecting heating element. Dryer shall produce 100 CFM at 130 F and 5000 LFM average velocity for 30 sec. (80 sec. for hair). Entire Unit U.L. listed and guaranteed against defects in material and/or workmanship for 10 years. Overall dimensions: 10-7/8"W x 10-3/8"H x 7"D (to tip of nozzle).

Surface Mounted Hand (Hair) Dryer shall be Bradley Model _____ (insert model number).