

HAND/HAIR DRYER

- Recess mounted
- Model 2875-28 **Bradex™**
Hand Dryer-Chrome Plated
- Model 2885-28 – Hand Dryer-Color
(Specify color _____)
- Model 2876-28 – Hair Dryer-Chrome Plated
- Model 2886-28 – Hair Dryer-Color
(Specify color _____)

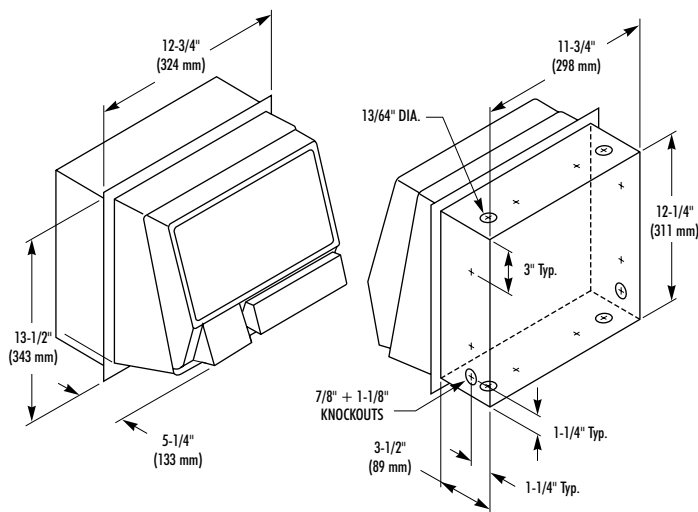

MODEL 2875-28/2885-28 2876-28/2886-28

CONSTRUCTION:

- **COVER, NOZZLE AND PUSHBUTTON:** Fabricated of rust and corrosion-free diecast zinc with satined chrome over nickel finish.
- **DRESS FLANGE:** Fabricated of stainless steel; neoprene gasket seal between cover and flange.
- **MOTOR:** PSC induction motor (brushless), 1/10 HP, thermally protected, self aligning quiet bearings, resilient ring motor mounts; no field lubrication required. 120 volt, 17 amp, 60 hz standard.
- **HEATING ELEMENT:** 2000 watt nickel chromium heating element blower and inlet mounted (inaccessible through nozzle), protected by self resetting disc thermostat.
- **SWITCH TIMER:** 25 ampere rating, enclosed switch. 30 second timer Model 2875/2885; 80 second timer Model 2876/2886; all timers are impedance protected.
- **BLOWER:** Operates at 3450 RPM delivering 100 CFM at 130 deg. F. and average velocity of 5000 LFM.
- **BASE PLATE:** Diecast aluminum.
- **AIR INLET:** Integrally cast in cover.
- **COVER LOCKING:** 1/4 inch diameter socket head safety screws; special wrench provided.
- **ENTIRE UNIT:** Is U.L. listed and guaranteed against defects in material and/or workmanship for ten (10) years.

OPERATION:

Press button and release to activate dryer.

INSTALLATION:

Requires rough wall opening 11-3/4"W x 12-1/2"H. Minimum recessed depth required is 3-1/2" from finished wall surface. Secure mounting box to rough-in with nails or screws; 2 attachment holes provided on sides, top and bottom of box. Bring wire into mounting box through electrical knockouts. Fasten base plate to wall box (fasteners provided with box). Connect electrical service to terminal block per cover mounted wiring diagram. Attach cover to base before energizing dryer at breaker panel.

OPTIONAL FEATURES

Feature	Suffix
<input type="checkbox"/> 208 Volt 10 amp, 60 Hz	-29
<input type="checkbox"/> 240 Volt 8.5 amp, 60 Hz	-53
<input type="checkbox"/> White epoxy finish	-33
<input type="checkbox"/> 220 Volt, 7.5 amp, 50 Hz	-48
<input type="checkbox"/> 240 Volt, 7 amp, 50 Hz	-49

GUIDE SPECIFICATION:

Recessed mounted hand (hair) dryer cover shall be fabricated of rust and corrosion free diecast zinc with fixed nozzle. Dress flange to be stainless steel with neoprene seal between flange and cover. Motor of PSC induction type with self aligning, self lubricating, quiet bearings; thermally protected. Automatic reset thermostat protecting heating element. Dryer shall produce 100 CFM at 130 F and 5000 LFM average velocity for 30 sec. (80 sec. for hair). Entire Unit U.L. listed and guaranteed against defects in material and/or workmanship for 10 years.

Overall dimensions: 12-3/4"W x 13-1/2"H x 5-1/4"D (to tip of nozzle).

Recess Mounted Hand (Hair) Dryer shall be Bradley Model _____
(insert model number).