

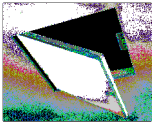

SESAME ACCESS DOOR MODEL KSTDW For Drywall Ceilings

DATE



KARP ASSOCIATES, INC.
54-54 43rd Street, Maspeth, NY 11378

SPECIFICATIONS

GENERAL SCOPE:

Access doors shall be Karp Type KSTDW as manufactured by Karp Associates, Inc., Maspeth, N.Y. Sizes shall be as indicated on the drawings.

CONSTRUCTION:

1. Frame shall be 20 gage galvanized steel.
2. Door shall be 20 gage galvanized steel and shall be lined with 3/8" mineral fiberboard.
3. Gasketing shall be flame retardant polyurethane.
4. Locks shall have plastic grommets and shall be square head key wrench operated.
5. Hinge shall be concealed pivot with a controlled action device (CAD), except for size 12" x 12".

STANDARD SIZES

DOOR SIZE H x W (INCHES)	SHIPPING WT. (LBS.)
12 x 12	8.2
18 x 18	16.7
24 x 24	17.6
36 x 24	44.4
48 x 24	32.6

PROJECT DATA					
Project Name:					
Architect:					
Contractor:					
Agent/Customer Name:					
Tagging Instructions:					
Special Instructions:					

PROJECT SCHEDULE					
Qty.	H	W	No. of Latches	Finish	Remarks

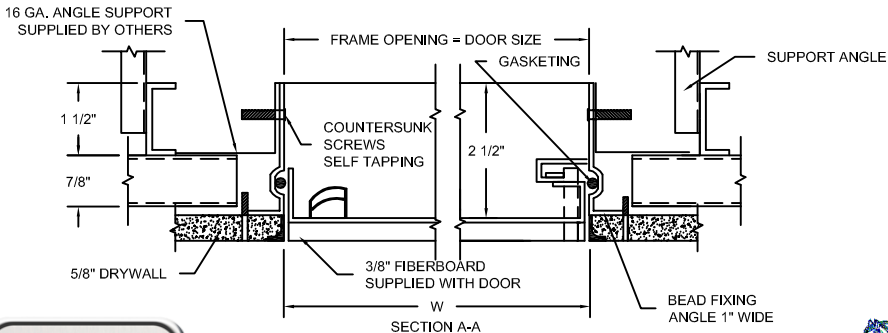
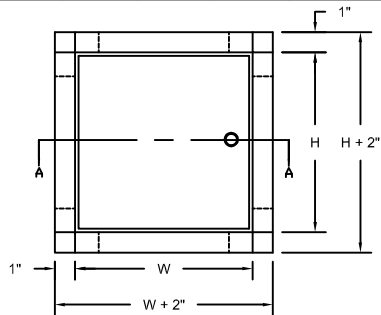

Distributed by
www.Ameraproducts.com
Phone: (800) 608-6568
Fax: (409) 840-5545
info@ameraproducts.com



Made with Union Labor