

SUBMITTAL: SECURITY/DETENTION FIRE EXTINGUISHER, VALVE AND HOSE CABINETS

JL security and detention cabinets for fire extinguishers, fire hoses or fire department valves are constructed to meet maximum security requirements in areas where fire protection is required. All recessed models have heavy-duty masonry anchors welded to the frame.

Door & Trim: 12 gauge (0.27 cm) steel or 14 gauge #4 satin finish stainless door. Flush cabinet doors are mounted in a 5/8" door stop and attached by a heavy-duty continuous hinge. Non-rated cabinets have 1-1/2" face trim on frame.

Trim Style & Depth: 1-1/2" trim on frame. Available in *Recessed* with flat trim, *Semi-recessed* with 2-1/2" square trim or *Surface-mount* model with square edge.

Tub: Steel models have 14 gauge steel with white powder coat primer finish. Stainless steel models have 14 gauge stainless tub. Heavy duty masonry anchors provided on recessed & semi recessed models

Lock Prep: Detention deadlock, detention slam lock or mortise cylinder. Select Below.

Fire-Rated: This cabinet is available as fire-rated. See the



SFC11 with Optional Detention Deadbolt DDI5010 Installed

STEP 1: Select Door & Trim Materials From Chart on Page 2

STEP 2: Select Lock Prep (Included in Price)

___ (DDP) Detention Deadlock Prep. (lock by others) Specify Type: _____

___ (DSP) Detention Slam Lock Prep. (lock by others) Specify Type: _____

___ (MP) Mortise Cylinder Cam Prep. (no additional cost unless brass ret. ring is required)

Specify Type: _____

STEP 2 A: If Lock Prep Not Select Above: Select Optional Lock by JL at Additional Cost:

___ (MDP) Mortise Deadbolt Prep. (lock by others) Specify Type: _____

___ Mortise Cylinder Cam Lock Installed : ___ (MP-SL-AMP) or ___ (MP-SL-1E74) ___ Other*

___ Mortise Deadbolt Installed: ___ (MDP-SL-AMP) or ___ (MDP-SL-1E74) ___ Other*

___ (DDI5010) Detention Deadlock Installed– example of key at right

___ (DDI5017) Detention Slam Lock Installed – example of key at right



*Other - Specify Mfg, Model and Keycut (if needed): _____

STEP 3: SELECT OTHER OPTIONS AT ADDITIONAL COST:

___ Red Powder Coat Finish for Steel Cabinets

___ Red Fire Extinguisher Lettering

___ Black Fire Extinguisher Lettering

___ Stainless Steel - 12 gauge # 4 Satin Finish. This model features stainless steel door, trim and tub.

___ **Customer-supplied Lock Installed.** Be Sure to Select Lock Prep

Above and Specify Mfg, Model: _____

___ #0646 Brass Retaining Ring for MP (may be required for locks by others)

 ACTIVAR INC. Construction Products Group	Distributor:	Quantity:
	Contractor:	Approved By:
	Model #:	Architect:
	Project:	Date: Copyright 2015 Activar

SHC, SVC AND SVC ARE TRADEMARKS OF ACTIVAR
PLEASE DOWNLOAD MOST CURRENT SUBMITTAL FROM WEBSITE BEFORE ORDERING

Distributed by
www.Ameraproducts.com
 Phone: (800) 608-6568
 Fax: (409) 840-5545
 info@ameraproducts.com

TRIM & DOOR MATERIAL & SERIES		TUB I.D. W x H x D in Inches			FRAME O.D. W x H in Inches		WALL OPENING			K.O. LOCATIONS		APPROX SHIP WT	RECOMMENDED HOSE, RACK & EXTINGUISHER			
QTY	STEEL	QTY	STAINLESS	TRIM STYLE	A	B	C	E	F	Width	Height	Depth		J	G	LBS
SECURITY FIRE EXTINGUISHER CABINETS (SFC)														View Fire Extinguisher Information		
	SFC-11		SSFC-31	Flat Trim	10-1/2	24	7	12-1/2	26	11-1/2	25	7 1/2	--	--	25	Cosmic & Galaxy 2.5-10, Mercury 2.5-5, Sentinel 5
	SFC-12		SSFC-32	2-1/2" Square Trim	10-1/2	24	7	12-1/2	26	11-1/2	25	5	--	--	26	
	SFC-13		SSFC-33	Surface Mount Sq.	13	26-1/2	8	13	26-1/2	--	--	--	--	--	26	
	SFC-15		SSFC-35	Flat Trim	12	27	8-1/2	14	29	13	28	9	--	--	33	Any Cosmic, Galaxy, Mercury, Saturn 15, Sentinel 5
	SFC-16		SSFC-36	2-1/2" Square Trim	12	27	8-1/2	14	29	13	28	6-1/2	--	--	34	
	SFC-17		SSFC-37	Surface Mount Sq.	14-1/2	29-1/2	10	14-1/2	29-1/2	--	--	--	--	--	34	
SECURITY VALVE CABINETS (SVC)																
	SVC-11		SSVC-31	Flat Trim	18	18	8-1/2	20	20	19	19	9	5	5	32	1-1/2" or 2-1/2" Fire Department Valve
	SVC-12		SSVC-32	2-1/2" Square Trim	18	18	8-1/2	20	20	19	19	6-1/2	4-1/4	4-1/4	33	
	SVC-13		SSVC-33	Surface Mount Sq.	20-1/2	20-1/2	10	20-1/2	20-1/2	--	--	--	--	--	33	
SECURITY HOSE CABINETS (SHC)																
	SHC-11		SSHC-31	Flat Trim	32-3/4	34-3/4	8	34-3/4	36-3/4	33-3/4	35-3/4	8-1/2	4	4	88	1-1/2" or 2-1/2" Hose Rack, & Extinguisher, or F. D. Valve & Extinguisher*
	SHC-12		SSHC-32	2-1/2" Square Trim	32-3/4	34-3/4	8	34-3/4	36-3/4	33-3/4	35-3/4	6	4	4	95	
	SHC-13		SSHC-33	Surface Mount Sq.	36-3/4	38-3/4	8	36-3/4	38-3/4	--	--	--	--	--	104	



SVC-13 With Optional Color

New—Deeper SFC 11 & 12, SSFC 31 & 32 Cabinet Now Fits 10 lb Cosmic and Galaxy!!

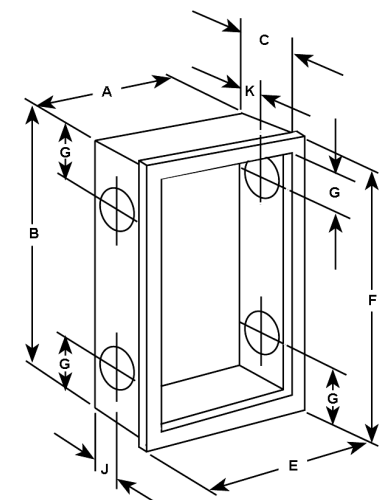

All Model Number Shown in **Blue Text** are ADA-Compliant

Distributed by
www.AmeraProducts.com
Phone: (800) 608-6568
Fax: (409) 840-5545
info@ameraproducts.com