



**STRIKE FIRST
CORPORATION**

K

SERVICE MANUAL (v1)

UL / ULC

WET CHEMICAL – HAND PORTABLE RESTAURANT KITCHEN FIRE EXTINGUISHERS

Model: SF-6LK / WBDL-6LK

All fire extinguishers should be installed, inspected & maintained in accordance with the National Fire Protection Association (NFPA) 10, 2007 Edition "Standard for Portable Fire Extinguishers" and the local authorities having jurisdiction.

When installation, inspection or maintenance is required, Strike First Corporation strongly recommends the work to be performed by NFPA 10 (2007) certified personnel. Fire extinguishers are pressure vessels and must be treated with respect and handled with care. They are mechanical devices and require periodic maintenance to be sure that they are ready to operate properly and safely.

Strike First Corporation makes O.E.M. parts available to insure proper maintenance. Substituting O.E.M. parts voids the Strike First warranty, as well as the UL & ULC Listings. **DO NOT SUBSTITUTE.**

Strike First Corporation does not service, maintain or recharge fire extinguishers. This manual is published as a guide to assist qualified service personnel in the inspection, maintenance and recharge of Strike First fire extinguishers only. **This service manual should be used in conjunction with the appropriate Parts Lists/Pictograms for each unit being serviced.** No service manual can anticipate all the possible malfunctions that may be encountered in the service of fire extinguishers. Due to the possibility that prior service performed on this equipment may have been improperly done, it is extremely important that all warnings, cautions and notes in this manual be carefully observed. Failure to heed these instructions could result in serious injury.

Strike First Corporation assumes no liability for service, maintenance or recharge of fire extinguishers by publishing this service manual.

For installation instructions of Strike First portable fire extinguishers please refer to all of the following:

1. Owner's Manual - included with the unit
2. NFPA 10 "Standard for Portable Fire Extinguishers – 2007 Edition
3. Local authorities having jurisdiction

For operation instructions on Strike First portable fire extinguishers please refer to one or all of the following:

1. Fire Extinguisher Nameplate/Label
2. Owner's Manual – included with the unit
3. NFPA 10 "Standard for Portable Fire Extinguishers – 2007 Edition
4. Your local authorized Strike First Distributor

WARNING: ALWAYS WEAR EYE PROTECTION WHEN SERVICING PRESSURIZED WET CHEMICAL FIRE EXTINGUISHERS.

CAUTION: PERSONS EXPECTED TO USE THIS FIRE EXTINGUISHER SHOULD BE TRAINED IN INITIATING ITS OPERATION AND IN THE PROPER FIRE FIGHTING TECHNIQUE.

RECHARGE FIRE EXTINGUISHERS IMMEDIATELY AFTER ANY USE





INSPECTION* (ref. 7.2 - NFPA 10, 2007)

The inspection procedures outlined below may not be sufficient for every jurisdiction or location and should be used in conjunction with the NFPA 10 Standard for Portable Fire Extinguishers, 2007 Edition.

Fire extinguishers shall be manually inspected when initially placed in service. The inspection is intended to give reasonable assurance that the extinguisher is fully charged and operable. This is done by seeing that it is in its designated place, has not been actuated or tampered with, and there is no obvious physical damage or condition to prevent operation.

WARNING: FOR SAFETY PURPOSES, IF AN EXTINGUISHER SHOWS SIGNS OF CORROSION OR MECHANICAL DAMAGE, IT SHALL BE SUBJECTED TO A HYDROSTATIC PRESSURE TEST OR REPLACED.

PERIODIC INSPECTION PROCEDURE

(Monthly or more often if circumstances dictate)

Periodic inspection of the fire extinguisher shall include a check of at least the following items:

1. Location in designated place
2. No obstruction to access or visibility
3. Fullness determined by weighing or hefting
4. Seal and tamper indicators not broken or missing
5. Operating instructions on nameplate are legible and facing outward
6. Examine for obvious physical damage, corrosion, leakage, or clogged hose and/or nozzle.
7. Pressure gauge is in the "green" operable area.

MAINTENANCE (ref. 7.2 & 7.3 - NFPA 10, 2007)

Maintenance, servicing & recharging shall be performed by trained and certified persons having available the appropriate servicing manual, the proper types of tools, recharge materials, lubricants, and Strike First O.E.M. replacement parts.

Fire extinguishers shall be subjected to maintenance at intervals of not more than 1 year, at the time of hydrostatic test, or when specifically indicated by an inspection. Extinguishers taken out of service for maintenance or recharge shall be replaced by spare extinguishers of the same type and at least an equal rating.

MAINTENANCE PROCEDURE

1. Clean extinguisher to remove dirt, grease or foreign material. **Avoid the use of solvents around the pressure gauge. This could damage the plastic face.** Check to make sure that the instruction nameplate and UL/ULC manifest are securely fastened and legible. Inspect the cylinder for corrosion, abrasion and dents. If any of these conditions are found or you doubt the integrity of the cylinder, hydrostatically test to factory test pressure, using the proof pressure method and a suitable cage, in accordance with CGA Pamphlet C-1 and The National Fire Protection Association (NFPA) Pamphlet No. 10 "Standard for Portable Fire Extinguishers" 2007 Edition.
2. Inspect the extinguisher and replace any parts that are damaged, missing, corroded or O.E.M. substitute parts. Only factory O.E.M. replacement parts are approved for use on Strike First fire extinguishers.
3. Weigh the extinguisher. Extinguisher weight MUST fall within the + / - tolerance of the total charged weight limits in the "MAINTENANCE" section on the label. Any extinguisher not falling within the tolerance limits shall be properly recharged.
4. Check the date of manufacture stamped on the hanger loop or the date of last hydrostatic test on the label affixed to the extinguisher. Cylinder must be hydrostatically tested every 5 years to test the pressure indicated on the nameplate. **Recharge with OEM Strike First wet chemical after hydrotest.**
5. Inspect the pressure gauge for damage. Depressurize and replace if necessary. If the pressure gauge indicator is below the green "RECHARGE" it may indicate a leak or discharge. If the pressure indicator is above the green "OVERCHARGED" it may indicate a faulty gauge or excess nitrogen. In both cases, depressurize and follow the recharge instructions.
6. Check pull (locking) pin for freedom of movement. Replace if bent or if removal appears difficult.
7. Check the discharge lever and rivets for freedom of movement. Inspect carrying handle and rivets for proper installation. If either is damaged, replace with OEM Strike First parts.
8. Remove hose assembly and inspect valve body interior for damage. Replace the hose if cut or cracked, or if threaded couplings are damaged. Blow air through the hose and nozzle assemblies using air or nitrogen at 50 psi (345 kPa) or less to insure that the passage is clear of foreign material.
9. Inspect valve assembly for corrosion or damage. Valve removal and / or valve part replacement should be made only after completely discharging the contents of the cylinder.
10. Reinstall hose assembly into the valve body. Hand tighten only.
11. Install new tamper seal and record service data on the extinguisher inspection tag.
12. Install the extinguisher on the wall hanger bracket in its proper location. Check for correct fit – replace bracket if necessary.

RECHARGING PROCEDURE

RECHARGING [NFPA 10, 7.4, 2007] IS THE REPLACEMENT OF THE EXTINGUISHING AGENT AND EXPELLANT FOR THIS TYPE OF EXTINGUISHER.

1. Discharge all remaining pressure and wet chemical, making sure there is no remaining pressure. Do not reuse or top off wet chemical.
2. Remove the valve assembly from the cylinder. Unscrew the spring retainer, using a wrench, from the valve assembly and remove the spring and valve stem assembly. Remove the collar o-ring from the valve assembly.
3. Thoroughly rinse all the parts with clean water and pat dry with a clean soft cloth. Blow air or nitrogen through the valve assembly. Inspect the collar o-ring, valve stem and valve assembly and replace worn or damaged parts. Lubricate the collar o-ring and the small valve stem o-ring with Parker O-Lube. Do not lubricate the Valve Stem Seal. Inspect the siphon tube and replace if damaged.
4. Remove the fill tube. Rinse the cylinder with clean water and inspect the interior according to CGA Visual Inspection Standard, Pamphlet C-6. Replace fill tube.
5. Recharge using Strike First wet chemical Part XXXX, following the instruction on the label.
6. Place a "Verification of Service" collar around the neck of the cylinder. Install the valve assembly and siphon tube to the cylinder and align with nameplate.
 - a. The valve assembly collar nut should only be hand tightened to a maximum of 125 in./lb. Over tightening with a wrench will damage the valve.
7. Fasten the recharge adaptor to the valve assembly and pressurize with nitrogen to 100 psi (690 kPa). The pressure regulator should be set at no more than 125 psi (862 kPa). Remove the recharge adaptor.
8. Carefully inspect the collar o-ring, gauge face and threads, cylinder welds and valve stem for leaks using leak detection fluid or a soapy water solution. Using air or nitrogen, blow out the leak detection fluid and wipe the extinguisher dry.
9. Install the hose assembly into the valve assembly. Hand tighten and install in hose band.
10. Install the pull pin with the loop at the front of the extinguisher. Install a new tamper seal. Record the recharge date on the new tag and attach to the extinguisher.
11. Weight the extinguisher to verify compliance within the parameters indicated on the extinguisher nameplate (label).

TROUBLESHOOTING GUIDE

WARNING: BEFORE ATTEMPTING TO CORRECT ANY LEAKAGE PROBLEM, BE SURE THAT THE EXTINGUISHER IS COMPLETELY EMPTY AND DEPRESSURIZED.

Note: Check to determine the source of the leak before the extinguisher is empty. Leakage repairs will require that the extinguisher be completely empty and the valve assembly removed.

When re-installing the valve assembly, the cylinder must be placed in a suitable securing vice and valve installed hand tight.

PROBLEM	CORRECTIVE ACTION
1. Leak at collar o-ring	Remove valve assembly, clean collar thoroughly and install new collar o-ring. Lubricate with Parker O-Lube.
2. Leak through valve	Remove spring and valve stem assembly. Install new OEM valve stem assembly. Check valve seat for scratches or foreign matter.
3. Leak around gauge threads	Once de-pressurized, remove gauge. Clean threads and re-install gauge using Teflon tape on gauge threads.
4. Defective gauge	Once de-pressurized, remove gauge. Install new OEM gauge using Teflon tape on gauge threads.
5. Restricted or intermittent discharge of chemical	Check hose assembly and nozzle for dirt, sediment or obstruction. Clean and replace parts as necessary.
6. Defect in the cylinder*	Contact a Strike First dealer if under warranty, otherwise – mark "CONDEMNED" and remove from service or return to owner.



LIMITED WARRANTY

STRIKE FIRST CORPORATION ("STRIKE FIRST") warrants its fire extinguishers ("Products") to be free from defects in material and workmanship for a period of six (6) years from the date of manufacture. Strike First's responsibility for defects in material or workmanship are limited to repair or replacement of the products for the original retail purchaser ("Consumer") only. This limited warranty does not cover defects resulting from modification, abuse, accident, alteration, misuse, exposure to corrosive conditions, or improper installation or maintenance. STRIKE FIRST is not responsible for the installation or the maintenance of the Products.

Defective Products for which a valid claim has been made shall be returned to STRIKE FIRST's facility at Scarborough, ON (416) 299-7767 for repair or replacement (or to other repair facilities pursuant to STRIKE FIRST's prior written authorization), and transportation costs to such locations shall be paid by Consumer.

STRIKE FIRST DOES NOT ACCEPT LIABILITY BEYOND THE REMEDIES PROVIDED IN THIS LIMITED WARRANTY, WHETHER BASED ON CONTRACT, NEGLIGENCE, STRICT LIABILITY OR OTHERWISE, INCLUDING WITHOUT LIMITATION DAMAGES FOR ANY PERSONAL INJURY, PROPERTY DAMAGE, OR ANY DIRECT, INDIRECT, SPECIAL, CONSEQUENTIAL, INCIDENTAL, EXEMPLARY OR PUNITIVE DAMAGES, AND INCLUDING WITHOUT LIMITATION ANY LIABILITY FOR THIRD PARTY CLAIMS, IN EACH CASE EVEN IF STRIKE FIRST HAS BEEN ADVISED OF THE POSSIBILITY THEREOF. LAWS OF SOME JURISDICTIONS DO NOT ALLOW THE DISCLAIMER OF CONSEQUENTIAL OR OTHER TYPES OF DAMAGES, AND CONSUMERS MAY ALSO HAVE OTHER RIGHTS WHICH VARY FROM JURISDICTION TO JURISDICTION. UNDER SUCH CIRCUMSTANCES, THIS LIMITED WARRANTY AND THE LIMITATIONS AND DISCLAIMERS HEREIN SHALL BE TO THE GREATEST EXTENT PERMITTED BY LAW.

THIS LIMITED WARRANTY CONTAINS THE ENTIRE WARRANTY PROVIDED BY STRIKE FIRST, AND SHALL BE IN LIEU OF ANY AND ALL OTHER WARRANTIES OR CONDITIONS, WHETHER EXPRESS OR IMPLIED, STATUTORY OR OTHERWISE, INCLUDING WITHOUT LIMITATION, IMPLIED WARRANTIES AND CONDITIONS OF MERCHANTABILITY AND FITNESS FOR A PARTICULAR PURPOSE.

Neither the Product distributor nor any other third party is authorized to make any conditions, representations or warranties on STRIKE FIRST's behalf. STRIKE FIRST neither assumes nor authorizes any representative or other person to assume for it any obligation or liability other than as expressly set forth herein.

Any disputes regarding or relating to this limited warranty will be resolved in the sole discretion of STRIKE FIRST.

REFERENCES IN THIS MANUAL:

NFPA 10	Standard for Portable Fire Extinguishers 2007 Edition
*CGA C-1	"METHODS FOR HYDROSTATIC TESTING OF COMPRESSED GAS CYLINDERS"
CGA C-6	STANDARD FOR VISUAL INSPECTION OF COMPRESSED GAS CYLINDERS

AVAILABLE FROM:

National Fire Protection Association P.O. Box 9101 Quincy, MA 02269-9101 www.nfpa.org
Compressed Gas Assoc., Inc. 1235 Jefferson David Hwy., Suite 501 Arlington, VA 22202 www.cganet.com





STRIKE FIRST CORPORATION

SERVICE MANUAL:
PART No. C250600

WET CHEMICAL (6L)

UL/ULC Rating: 1A : K

Models: SF-6LK & WBDL-6LK

ITEM #	PART #	DESCRIPTION
1	C160210	Hose Band
2	W162680	Wet Chem. Hose Assembly (Incl. Nozzle)
3	-	Cylinder
4	W163600	Siphon Tube Assembly
5	W160600	Wall Hook
6	W163650	Fill Tube
7	W163605	Brass Spring Retainer
8	W161630	Spring
9	W161628	Valve Stem Assembly
10	W161645	Valve Body O-ring
11	-	Valve Body
12	-	Valve Body Collar
13	W162603	Carry Handle Rivets
14		Top Lever Rivet
15	W160695	Carry Handle
16	W160614	Top Lever
17	C110230	Pull Pin Retaining Strap
18	C951236	Large Pull Pin
19	GW100PSI	Wet Chem. Gauge - 100PSI
20	W31161	Wet Chem Valve Assembly - Complete
21	SF-3LK	Wet Chem Recharge (3L) - Not shown
22	SF-18LK	Wet Chem Recharge (18L) - Not shown

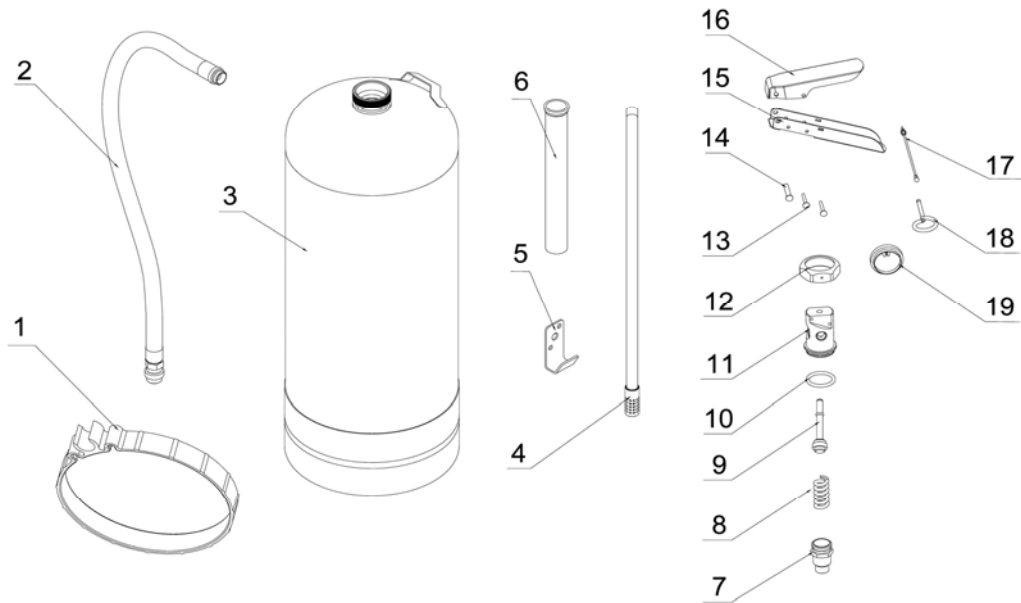

*** NOTE - Valve Body Assemblies include: Top Lever, Carry Handle, 3 x Rivets, Valve Body, Gauge, Valve Body Collar, O-Ring, Pull Pin & Retaining Strap**

Distributed by
www.Ameraproducts.com
 Phone: (800) 608-6548
 Fax: (409) 840-3341
info@ameraproducts.com

