



A WATTS Brand

9989-000000 Universal Changing Table

- Surface-mounted/Floor-mounted
- Automatic retracting feature stops operation and reverses direction if it detects an obstruction (requires weight to be on tray for feature to work)
- Color is silver and white
- Adjustable Height 16" to 39"
- ADA compliant

Product Materials

Bacterial resistant and free of added chemicals. The unit is a 304 brushed stainless steel shroud, vacuum formed ABS changing surface with a powder coated steel frame.

STRENGTH NOTE: Unit able to support a static load of up to 500 lbs. Certified to UL 962 and CSA C22.2 NO.68

Installation

Reference Pre-Installation Guide and Assembly Instructions for more detailed information, including recommended blocking. Engineered to mount to most existing walls.

Convenient plug-in (120v 20A GFCI outlet) feature requires a GFCI outlet / GFCI protected circuit or hardwire depending on installation needs.

WARNING: Be sure to use reinforced backing behind wall where mounting screws or anchoring devices are installed to ensure adequate support for the Universal Changing Table. All anchoring devices must be appropriate for specific wall construction. Severe personal injury and/or property damage may result from improper mounting.

Guide Specification

Surface mounted Universal Changing Table with (2) control buttons (on tray and side of shroud) allows for a smooth open and close. Features a soft-plunge tray, safety sensor, indicator lights, sound warning and back up battery system.

Overall dimensions:

Closed: 76.75"W x 69"H x 9.5"D

Open: 76.75"W x 69"H x 41"D

Usable Tray Size: 70.5"W x 30.125"D

Overall table surface size: 76.6"W x 34.75"D

Complementary Bradley Products

- [Childcare Solutions](#)
- [Paper Towel & Waste](#)
- [Mirror & Shelves \(w/ Hooks\)](#)
- [Diplomat Hand Sanitizer](#)

Orders composed of products indicated as **Bradex**® will be available to ship in three days after receipt of order at the factory. There is no pricing penalty for this service from Bradley.

Page 1 of 1

2/3/2025

This information is subject to change without notice.

Bradley_UniversalChangingTable_9989

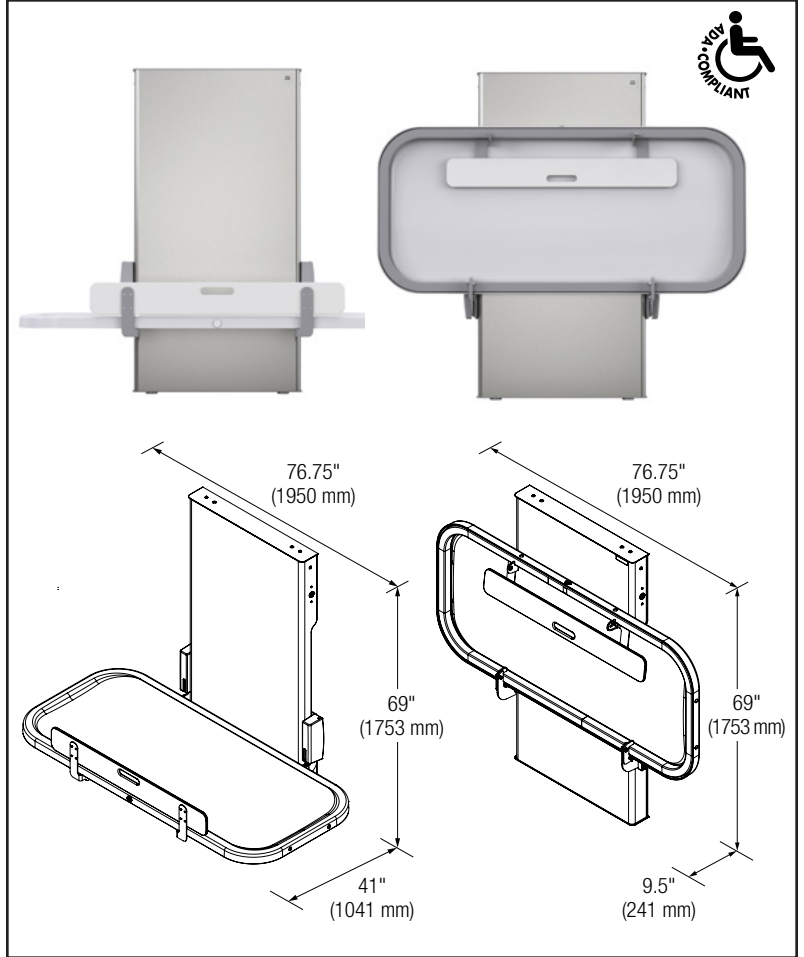

Product Compliance

- Consult local and national accessibility codes for proper installation guidelines.
- Conformity and compliance to local and national codes is the responsibility of the installer.

Complies with:

- UL 962 and CSA C22.2 NO.68
- IPX6 Ingress Rating
- IK10 Impact Rating
- IBC 2024
- ADA Compliant



Service Parts Available

No service parts available at this time.

