



INSTALLATION INSTRUCTIONS

9569 SEATS

IMPORTANT: PROPER BACKING MATERIAL AND MOUNTING HARDWARE MUST BE USED TO MOUNT THIS SHOWER SEAT FOR SAFE USE AND AS REQUIRED BY A.D.A. GUIDELINES.

ADA regulations specify a finished seat height 17" to 19" above the finished floor and 1½" of clearance between the seat edge and the side wall.

PLEASE READ THESE INSTALLATION INSTRUCTIONS THOROUGHLY PRIOR TO INSTALLING THIS SHOWER SEAT

IMPORTANT: THIS PRODUCT SHOULD ONLY BE INSTALLED BY QUALIFIED AND TRAINED PERSONNEL

FAILURE TO FOLLOW THESE INSTRUCTIONS COULD LEAD TO IMPROPER INSTALLATION OF THE SHOWER SEAT, STRUCTURAL AND/OR WATER DAMAGE TO THE WALL AND IN-WALL SUPPORT STRUCTURES, AND/OR SERIOUS BODILY INJURY IN USE. IN ADDITION, ALL WARRANTIES, EXPRESS OR IMPLIED, WILL BE NULL & VOID DUE TO IMPROPER INSTALLATION OF THIS PRODUCT. THE MANUFACTURER DOES NOT ASSUME ANY LIABILITY FOR DAMAGE RESULTING FROM SERVICES PERFORMED BY OTHERS, OR FAULTY INSTALLATION, MISUSE OR MISAPPLICATION OF GOODS.

THIS PRODUCT IS DESIGNED TO MEET OR EXCEED ALL LOAD REQUIREMENTS ESTABLISHED IN THE AMERICANS WITH DISABILITIES (ADA) ACT AND/OR FEDERAL SPECIFICATION WW-P-541/8b AT 250 POUNDS OF FORCE. THE PERFORMANCE OF THIS PRODUCT IS SIGNIFICANTLY IMPACTED BY THE STRENGTH AND CONSTRUCTION OF THE WALL TO WHICH IT IS ATTACHED.

TO ASSURE PROPER AND SAFE INSTALLATION, BE SURE TO USE REINFORCED BACKING BEHIND WALL WHERE MOUNTING SCREWS OR ANCHORING DEVICES ARE INSTALLED TO ENSURE ADEQUATE SUPPORT FOR THE SHOWER SEAT. ALL ANCHORING DEVICES (SUPPLIED BY INSTALLER) MUST BE APPROPRIATE FOR SPECIFIC WALL CONSTRUCTION.

1. Determine desired shower seat location and seat configuration.

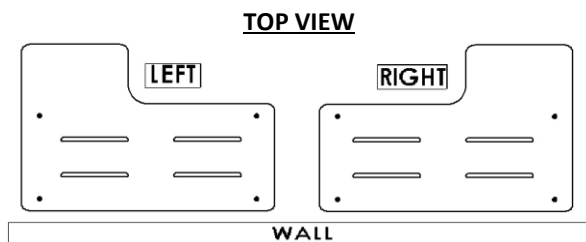

Determine desired location for the shower seat and corresponding seat configuration; left or right.

SEAT CONFIGURATION

2. Mounting the seat top to the frame.

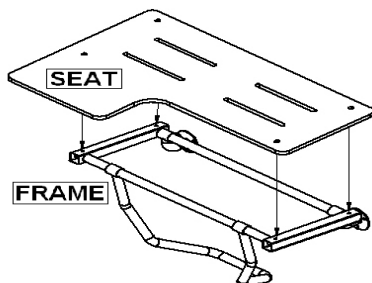

Mount the seat top to the frame in the desired configuration. Using four (4) ¼"-20 x 2" Phillips Flat Head machine screws and (4) ¼"-20 Nylon Lock Nuts (supplied by manufacturer), secure the seat top to the frame. Torque screws to 20 ft-lbs.



3. Determine seat height from the floor and location relative to the inside back wall.

ADA regulations specify a finished seat height 17" to 19" above the finished floor and 1-1/2" clearance between the seat edge and the inside back wall. Check local building codes for additional requirements.

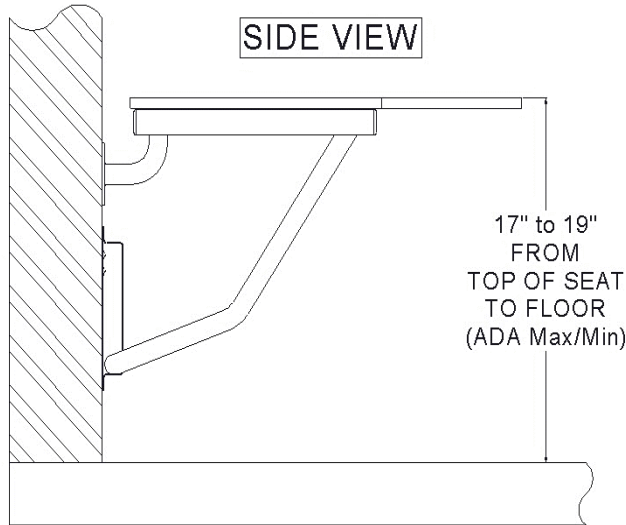

Diagram A

Place the seat against the wall where minimum 2" thick, solid wood in-wall backing material is located and ensure the appropriate finished seat height is at the desired height and is level. (See Diagram A)

Verify that the seat edge is at the desired distance from the side wall and is level and plumb, and the sliding leg bracket fits flush against the wall and is clear from the floor.

Upon selecting the height & location of the seat, mark the three (3) holes on each of the 3" diameter mounting flanges (six [6] holes total) on the wall where the seat will be mounted. Use the Shower Seat Mounting Flange Template (supplied by manufacturer) as necessary.

Using a 1/8" Carbide tip drill bit (not provided), drill at all six (6) locations.

Use clear silicone sealer at each hole location to prevent water damage to existing structures as desired.

4. Mounting the seat to the wall.

Holding the seat assembly in an upright and raised position against the wall, tightly secure the two mounting flanges to the wall **AND INTO 2" THICK, SOLID WOOD IN-WALL BACKING MATERIAL**, using six (6) appropriate anchoring devices (supplied by Installer).

*Tighten screws completely **AFTER** all screws are in place.*

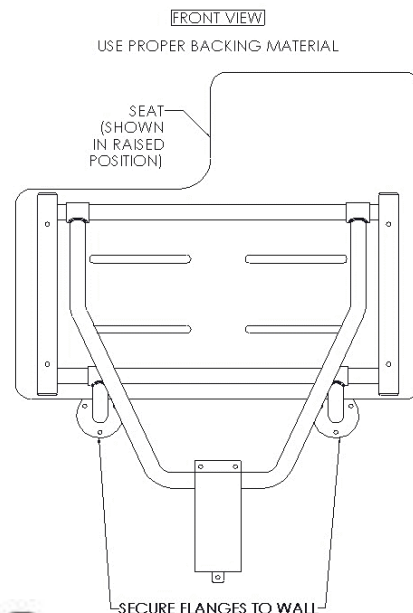

5. Determining the Location of the mounting holes for the Sliding Leg Bracket:

- Place the Sliding Leg Bracket around the Leg Support tube and affix the Sliding Leg Bracket against the wall on the established centerline of the seat. Rotate the seat top from down (horizontal) to up (vertical) positions to ensure the Sliding Leg Bracket is positioned properly. Mark the two top holes and the bottom hole in the Sliding Leg Bracket. (See Diagram 3A)
- Using a 3/32" Carbide tip drill bit (not provided), drill the two top mounting holes and the bottom tab mounting hole for the Sliding Leg Bracket.
- Secure the Sliding Leg Bracket to the wall **AND INTO 2" THICK, SOLID WOOD IN-WALL BACKING MATERIAL**, using (3) appropriate anchoring devices (supplied by Installer).

EXAMPLE:

For a 34-1/2" wide seat with hard-surface (Phenolic) seat top, see Diagram 3A

ADA regulations specify a finished seat height 17" to 19" above the finished floor and 1-1/2" clearance between the seat edge and the inside back wall.

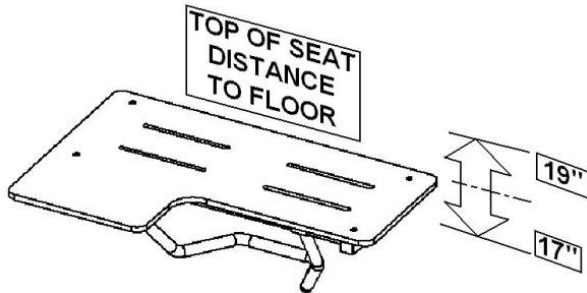

Measure and mark the appropriate finished Seat Height (Line "A" on Diagram 3A). The top of the seat should be straight and level. Locate the side edge of the seat top at 1-1/2" from the inside back wall. Mark the hole locations for the mounting flanges and the sliding leg bracket as described in steps 3, 4 and 5.

Example: *Finished seat height: 19" & width of the seat: 34-1/2"
 Maximum distance from the inside back wall to the edge of the seat: 1 1/2".
 Therefore, the center of the seat will be: 1/2 (34-1/2) + 1 1/2" = 18-3/4" from the side wall.*

6. Check Seat for:

- | | |
|----------------------------------|--------------------------------|
| 1) Proper up and down operation. | 3) Correct distance from wall. |
| 2) Correct finished height. | 4) Weight bearing. |



THIS COMPLETES THE INSTALLATION OF THE 9569 SHOWER SEAT.



Hardware provided:

(4) 1/4"-20 X 2" Phillips Flat Head machine screws and (4) 1/4"-20 Nylon Lock Nuts

Tools required:

Tape measure, masking tape, power drill, 1/8" and 3/32" Carbide tip drill bit, marking pen/pencil, level.

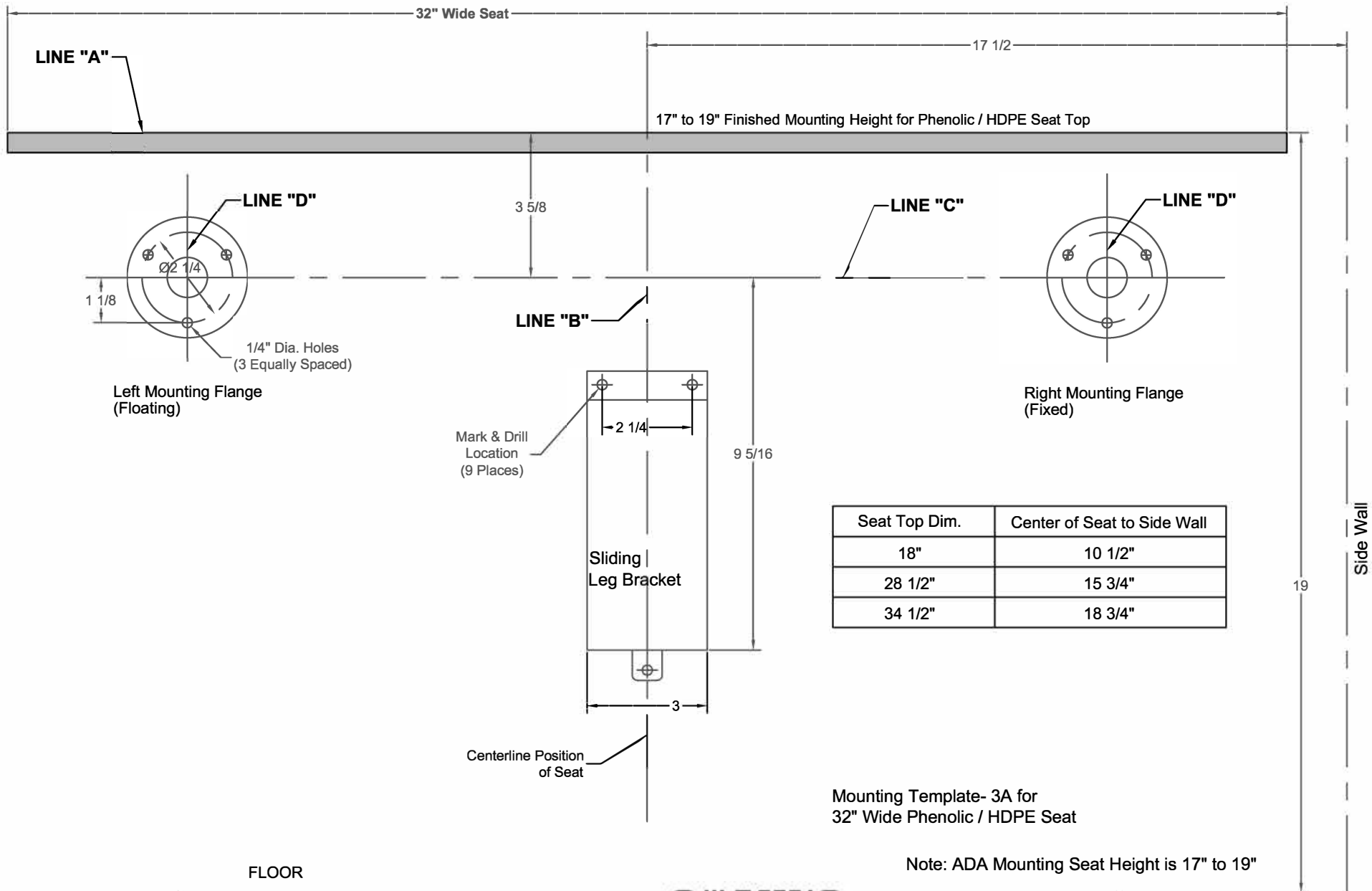

Seat Top Dim.	Center of Seat to Side Wall
18"	10 1/2"
28 1/2"	15 3/4"
34 1/2"	18 3/4"

Mounting Template- 3A for
32" Wide Phenolic / HDPE Seat

Note: ADA Mounting Seat Height is 17" to 19"

Example Only:
Sample Seat Size = 32" Wide Hard Surface (Phenolic/HDPE) Seat Top



Distributed by
www.Ameraproducts.com
Phone: (800) 608-6548
Fax: (409) 840-5545
info@ameraproducts.com

DIAGRAM #3A

Installation Instructions
3/29/2024

17" to 19" Finished Mounting Height for Phenolic / HDPE Seat Top

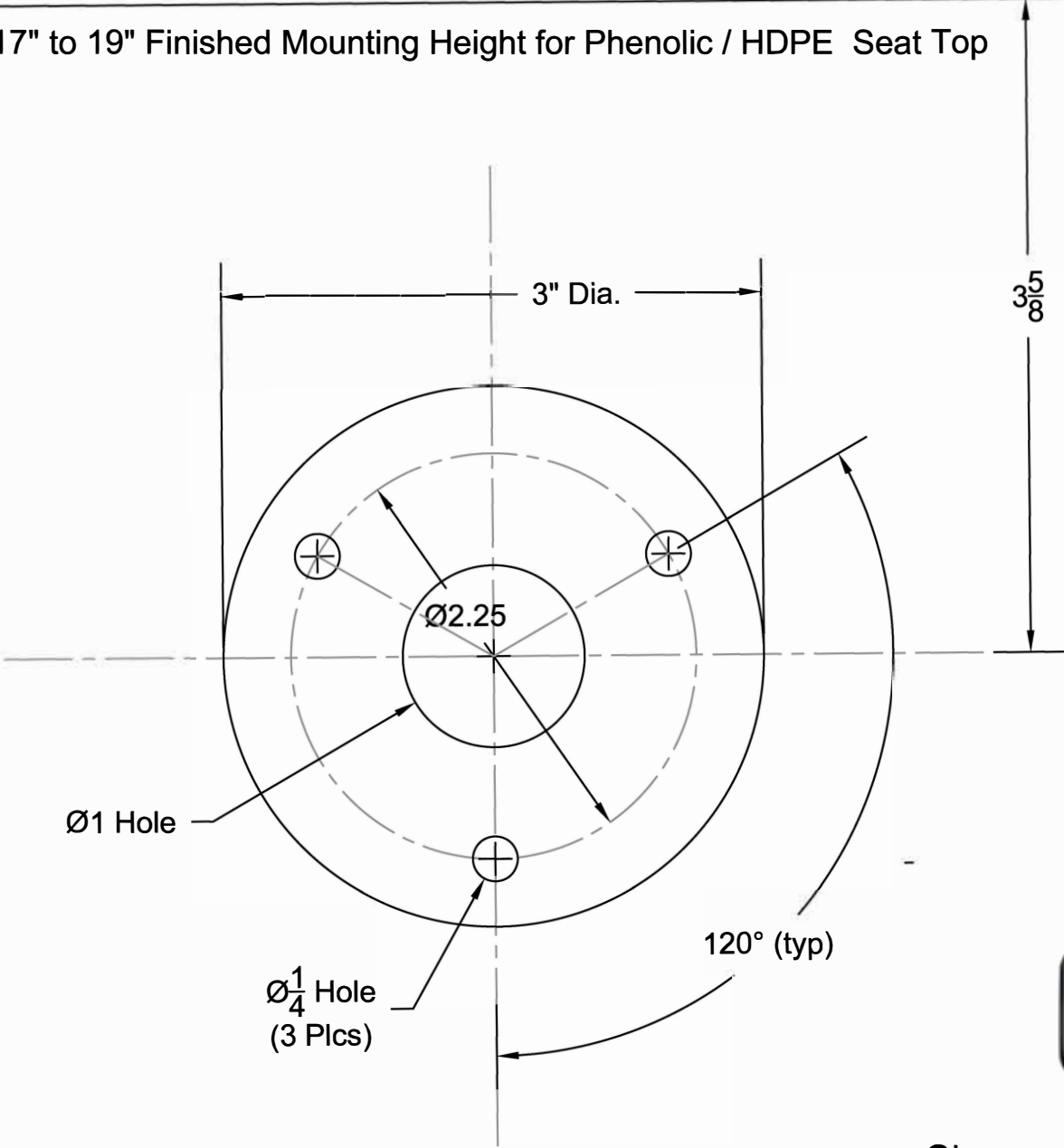

Distributed by
www.Ameraproducts.com
Phone: (800) 608-6568
Fax: (409) 840-3541
info@ameraproducts.com



Shower Seat Mounting Flange Template