

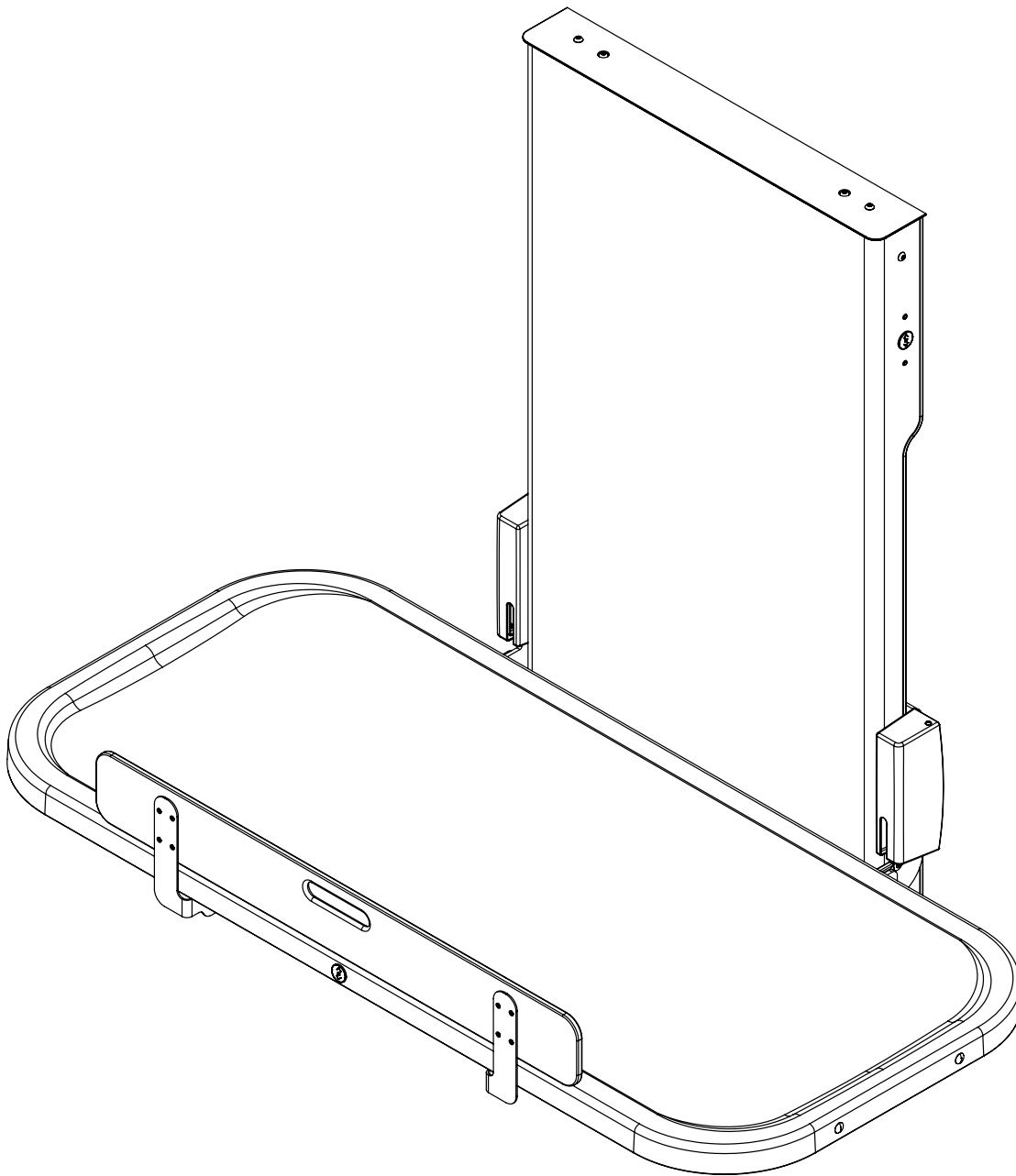







Ascent™ Universal Changing Table 800SS-01



Distributed by
www.AmeraProducts.com
Phone: (800) 608-6568
Fax: (409) 840-5542
info@ameraproducts.com

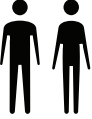

SYMBOLS

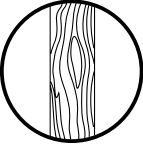
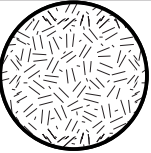
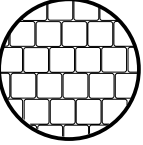
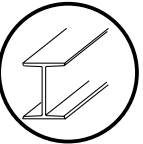
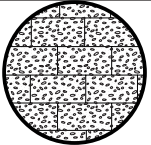
	CAUTION: This symbol indicates that caution is necessary when operating the device or control close to where the symbol is placed, or to indicate that the current situation needs operator awareness or operator action in order to avoid undesirable consequences.
	WARNING: This symbol indicates a hazardous situation which could result in serious injury or even death if not avoided.
	WARNING: This symbol indicates a hazard relating to electricity/voltage.
	2 PERSON ASSEMBLY: This symbol indicates step must be performed with two people.
	To signify an auditory indicator.
	To signify a prohibited action.
	To signify an acceptable action.
	Wood stud wall.
	Drywall.
	Tile covered wall. *Installation not UL evaluated
	Metal stud wall.
	Block or concrete wall. *Installation not UL evaluated



IMPORTANT SAFETY INSTRUCTIONS

READ ALL INSTRUCTIONS BEFORE USING THIS PRODUCT.

When using a Motorized Universal Changing Table, basic precautions should always be followed, including the following:

FURTHER WARNINGS AND CAUTIONS MAY BE SPECIFIED IN THE RELEVANT CHAPTERS THROUGHOUT THIS DOCUMENT.

WARNING

Review the assembly instructions to confirm that the appropriate critical components and accessories are being used with the product.

These instructions must be read and understood before installing or using this equipment. Failure to comply with these instructions may result in accidents resulting in serious personal injury or the product being damaged.

No modification of this equipment is allowed without express authorization from Foundations. If you suspect that any individual parts may be damaged contact Foundations. Do not remove, attempt to repair, or install parts yourself unless directed to do so by Foundations Technical Support.

CAUTION

This product must be installed by a knowledgeable contractor. Foundations cannot be held liable for injury to persons or damage to property caused by faulty installation.

Environmental Factor	Operating Range
Temperature	40°F to 95°F (5°C to 35°C)
Relative Humidity	0% to 80% @ 85°F (30°C) (non condensing)
Height Above Sea Level	Max 9,800 ft



IMPORTANT SAFETY INSTRUCTIONS

WARNING

To avoid the risk of electric shock, this equipment must be used with a GFCI Class A type outlet or GFCI Class A protected circuit.

The height adjustable changing table is powered by a 24VDC control system with battery backup. The battery enables the use of the changing table in the event of a main power loss. It is crucial that the main power supply is on at all times to maintain the charge of the backup battery. The backup battery needs to always remain connected to the rest of the system, the battery is connected during product installation and should not be accessed by user.

WARNING

TO REDUCE THE RISK OF BURNS, FIRE, ELECTRIC SHOCK, OR INJURY
TO PERSONS:

1. Unplug from the outlet before putting on or taking off parts.
2. Close supervision is necessary when this product is used by, or near children, invalids, or disabled persons.
3. Use this product only for its intended use as described in these instructions. Do not use attachments not recommended by the manufacturer.
4. Never operate this product if it has a damaged cord or plug, if it is not working properly, if it has been dropped or damaged, or dropped into water. Contact customer service for examination and repair.
5. Keep the cord away from heated surfaces.
6. Never drop or insert any object into any opening.
7. Do not use outdoors.
8. Do not operate where aerosol (spray) products are being used or where oxygen is being administered.









WARNING - RISK ON INJURY

Do not use where children or people with cognitive disabilities could be present and unsupervised

WARNING

RISK OF ELECTRIC SHOCK -Connect this product to a properly grounded outlet ONLY.

PRODUCT INFORMATION

Pb	The battery used in this product contains Lead.
IPX6	This product has been tested for water ingress in accordance with IPX6. * Compliance for this rating was evaluated by a third-party lab, not UL.
IK10	This product has been tested for external mechanical impacts in accordance with IK10.
	The maximum working load for this product is 500 lbs (227 kg).
	Parts of this product can be recycled.
	Parts of this product must be separated when being disposed of.
	The lifting range of this product is 16" (400 mm) to 39" (990 mm).
	This product is for indoor use only.
	Made in the USA using domestic and international components.





PRE-INSTALLATION GUIDE

CAUTION

- Only installations to drywall, wood, and steel studs is UL Evaluated. All other attachment methods and recommendations for blocking are considered as guidelines only, as each application is unique and should be reviewed by an architect, structural engineer or knowledgeable contractor.
- Foundations cannot be held responsible for reinforcements made in a faulty manner.
- The recommendations for concrete are based on manufacturer's experience and internal test results.
- Information is subject to change without further notice.

ANCHOR MAXIMUM LOAD CAPACITY

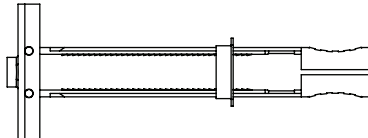
Anchor	Maximum Load
#14 x 3" (Part A) 	Wood Stud: 469 lbf
Alligator Anchor A10 with #14 SMS x 3" long (Part C) 	3.5 KSI Poured Concrete: 1168 lbf
	Concrete Block (Solid Section): 600 lbf
Snap Toggle Anchor (Part D) 	5/8" Drywall & 25 Gauge Steel Stud: 576 lbf
	1/2" Drywall & 25 Gauge Steel Stud: 466 lbf
	5/8" Drywall & 7/16" OSB Fiber Board: 800 lbf
	Concrete Block (Hollow Section): 1745 lbf

STANDARD ASSEMBLY

This unit has been designed for easy retro fitment for certain pre-existing wall applications. The requirement for this is 3 wood studs / metal studs (25 gauge) spaced 16 inches on center or block/concrete walls. For walls using stud construction, please contact an architect or structural engineer to ensure the wall is load bearing and can support the forces that this unit will exert on the wall.

BLOCKING WHEN REQUIRED

The options shown below are to install this unit when the layout of the restroom does not allow for the unit to be aligned with 3, 16" on center studs. The reinforcement of walls should always comply with all applicable building codes and be installed by a knowledgeable contractor.



REINFORCEMENT OF WALL WITH WOOD

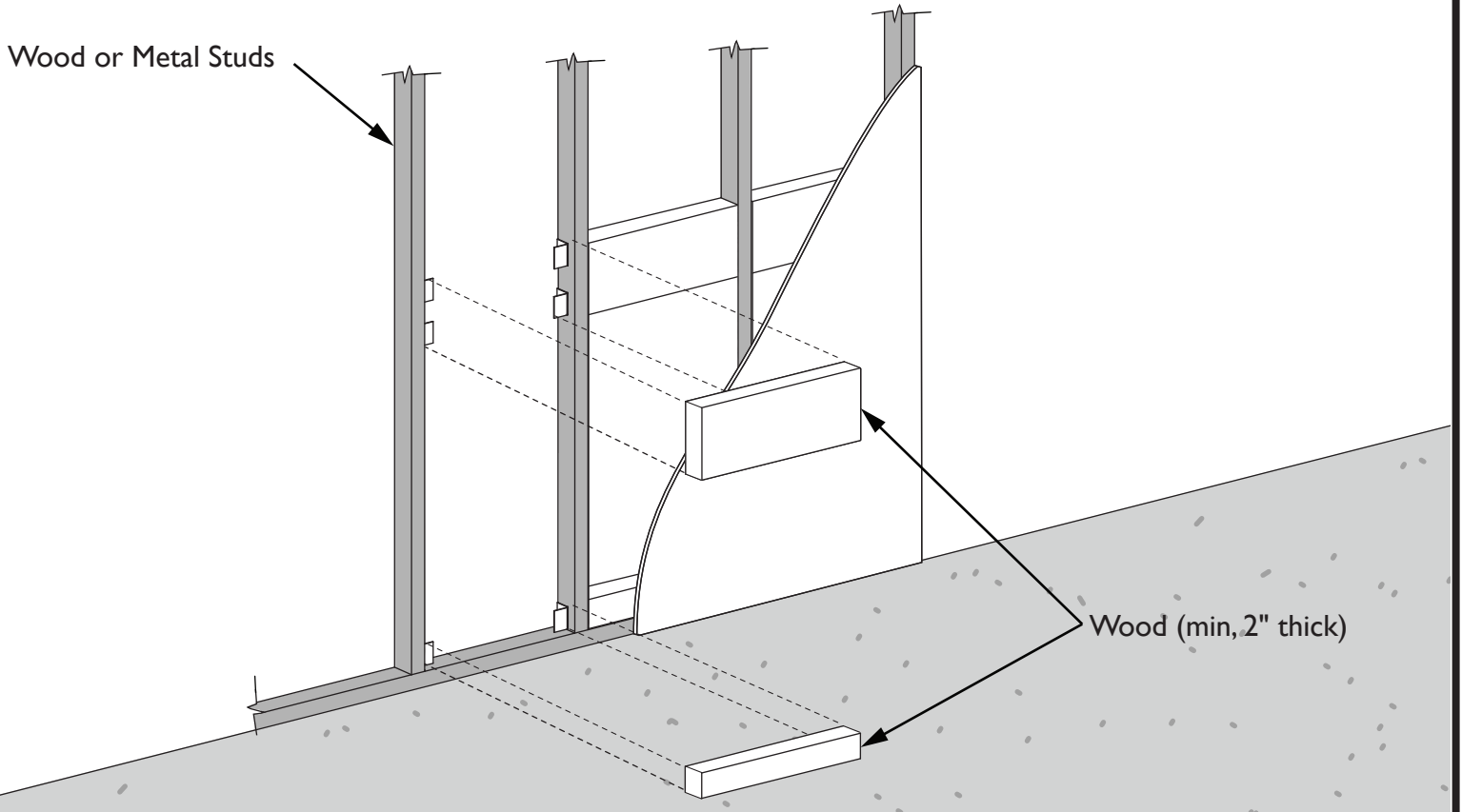

REINFORCEMENT OF WALL WITH PLYWOOD

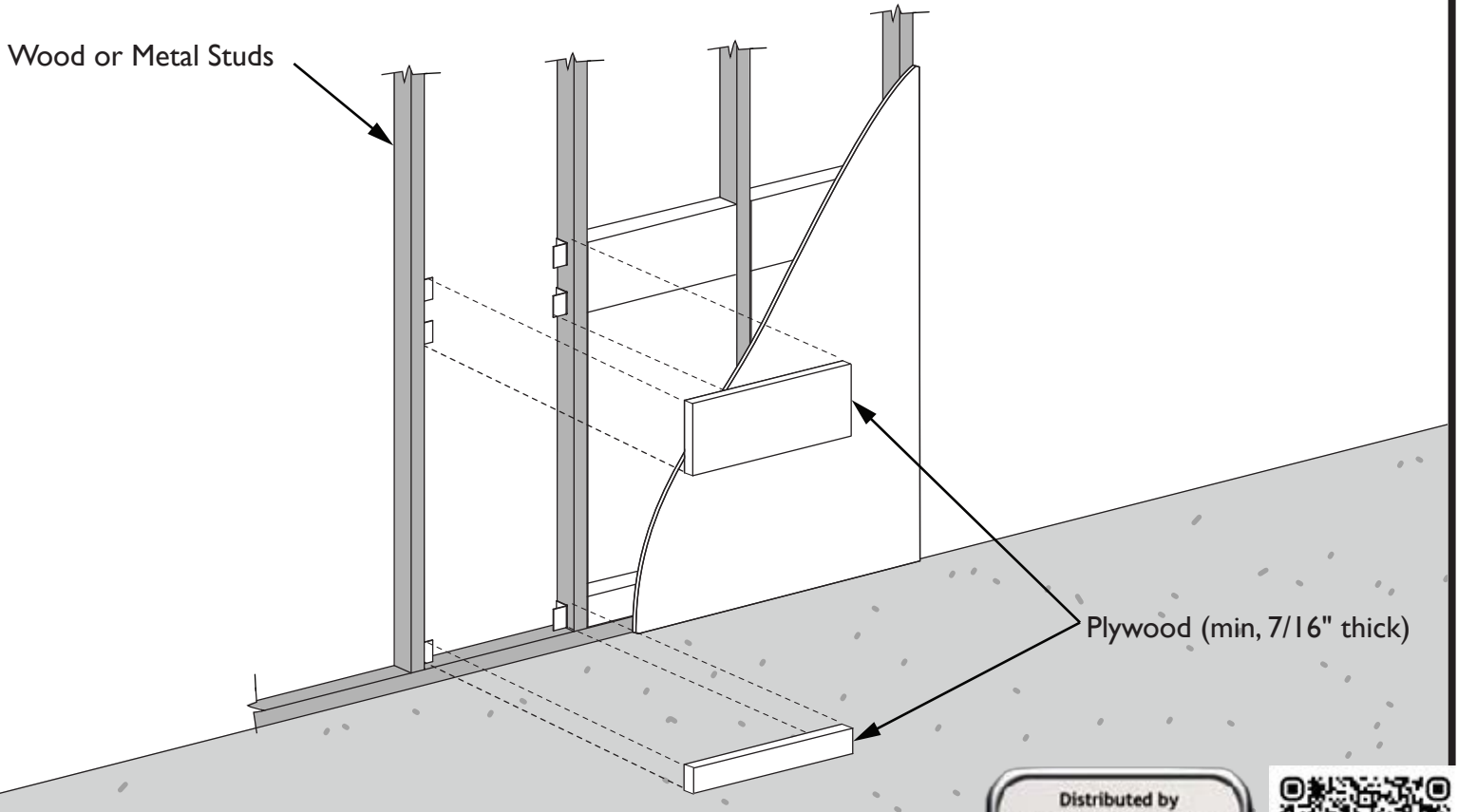

Distributed by
www.Ameraproducts.com
Phone: (800) 608-6548
Fax: (409) 640-5541
info@ameraproducts.com



WIRING OF UNIT



POWER REQUIREMENTS

Always ensure that the circuit is disconnected before altering existing construction to reduce the risk of electrical shock.

- Input ratings: 100-240V, 60Hz, 3.9 max
- 100-240 VAC, 50/60 Hz, -15% / +10%.
- Duty cycle: 10% - 2/18 min. on/off continuous use.



PLUGGING UNIT INTO MAIN POWER

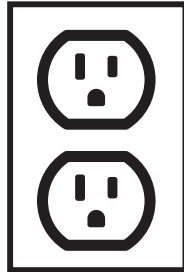
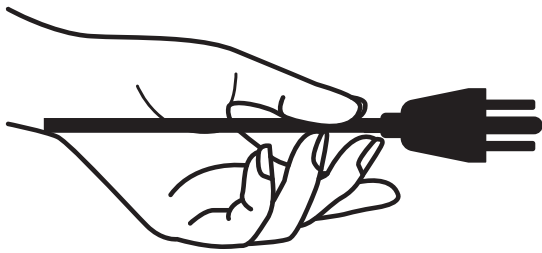

Unit needs to be plugged into a 120v 20A GFCI outlet. If a duplex outlet is being used the installer needs to ensure it is part of a GFCI protected circuit. Always use a qualified electrician to verify the componentry meets requirements and installation is done per all applicable building codes. To maintain a water ingress rating, ensure an appropriate While-in-use cover is installed on the outlet box. See Fig. I (page 8) for outlet location



HARDWIRING UNIT

Any modification to the product including modification of the supply cord or connecting means will invalidate and void the UL Listing, and does not comply with the National Electrical Code.



GROUNDING REQUIREMENTS

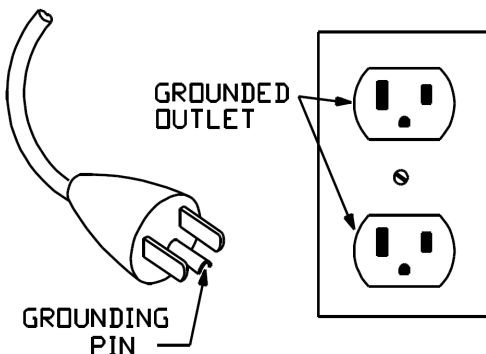

This product is for use on a nominal 120-volt circuit and has a grounding plug that looks like the plug illustrated below. Make sure that the product is connected to an outlet having the same configuration as the plug. No adapter should be used with this product.



OUTLET AND HOLE LOCATIONS (FIG. 1)

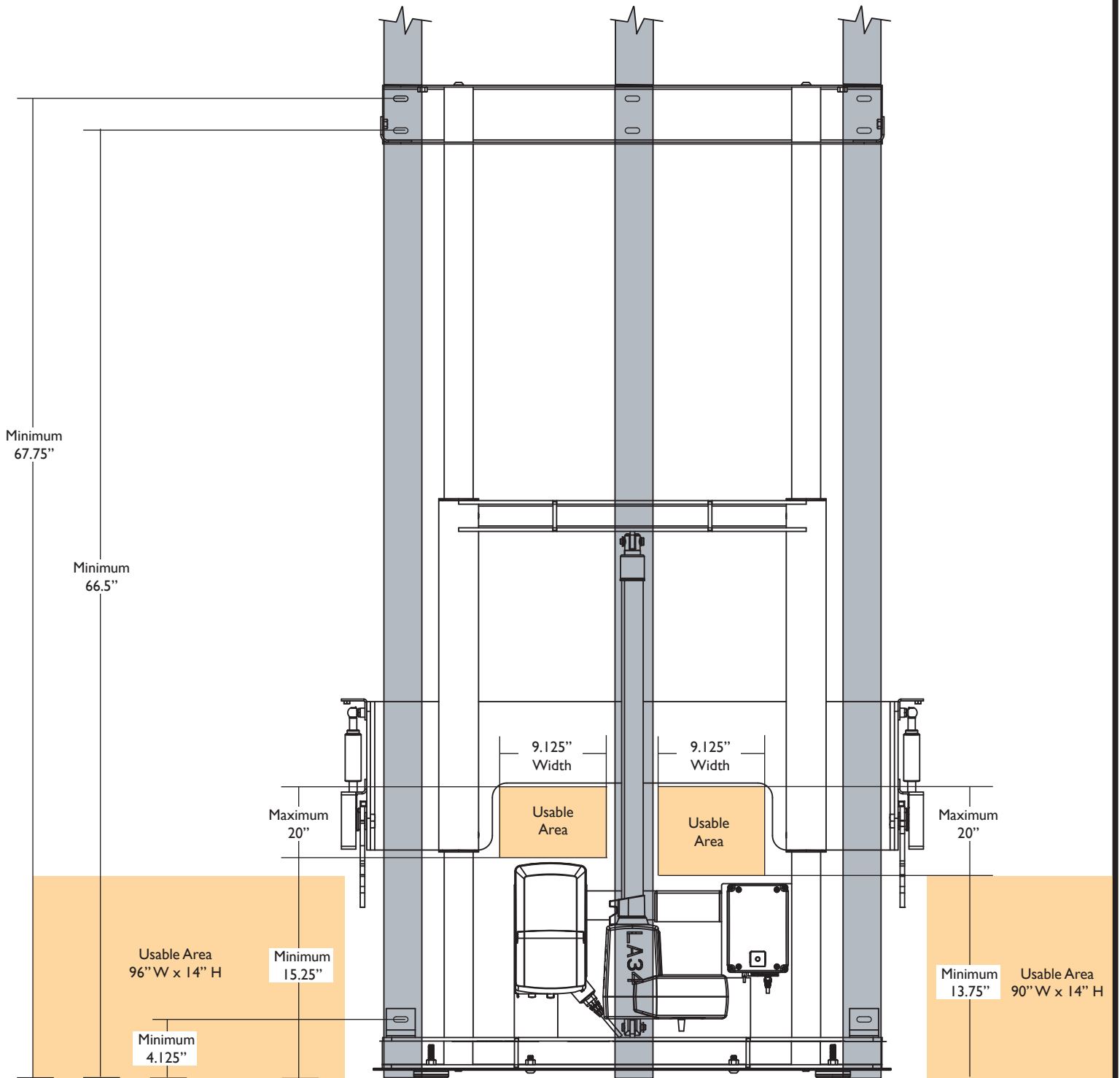

Distributed by
www.Ameraproducts.com
Phone: (800) 608-6548
Fax: (409) 640-5541
info@ameraproducts.com



TOOLS NOT INCLUDED

Distributed by
www.Ameraproducts.com
 Phone: (800) 608-6548
 Fax: (407) 840-9942
info@ameraproducts.com

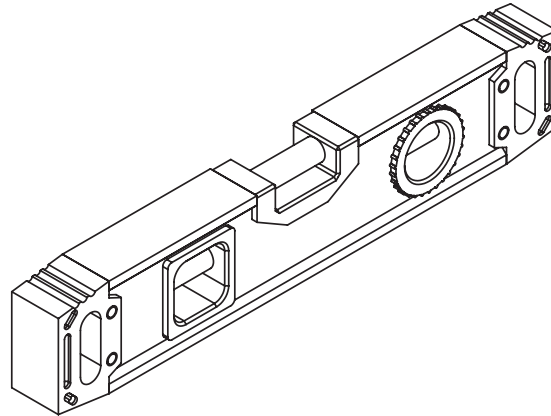
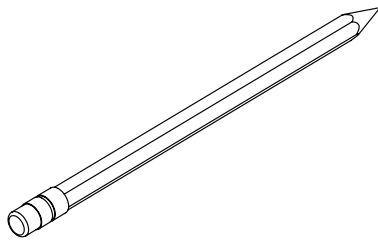
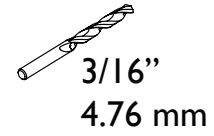
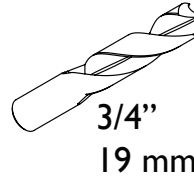
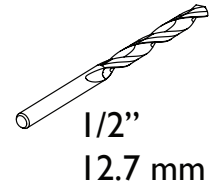
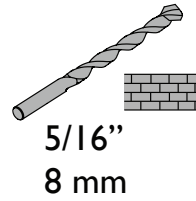
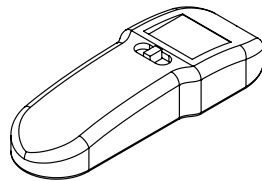
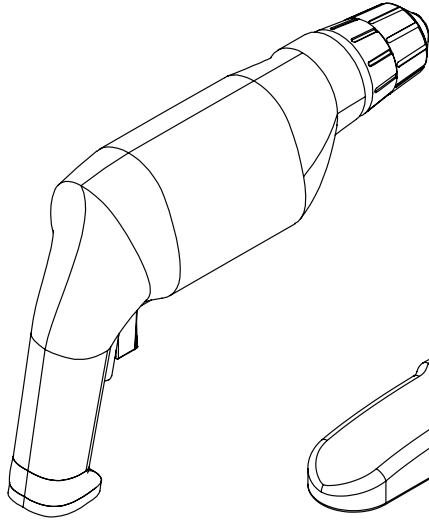
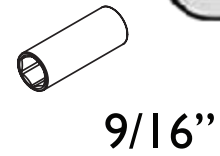
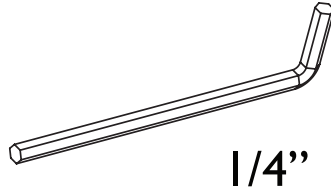

Part Description	Quantity Needed
#3 Phillips Head Bit	1
1/4" Allen Key/Bit	1
9/16" Socket Wrench	1
Electric Drill	1
Stud Finder	1
5/16" Drill Bit	1
1/2" Drill Bit	1
3/4" Drill Bit	1
3/16" Drill Bit	1
Pencil	1
Level	1

INCLUDED HARDWARE

Distributed by
www.Ameraproducts.com
 Phone: (800) 608-6548
 Fax: (409) 840-5541
info@ameraproducts.com

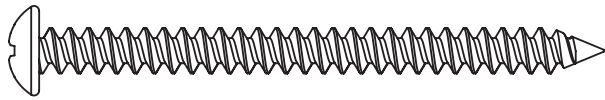

A

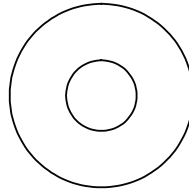

B

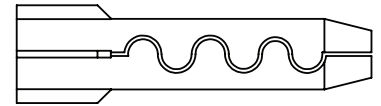

C

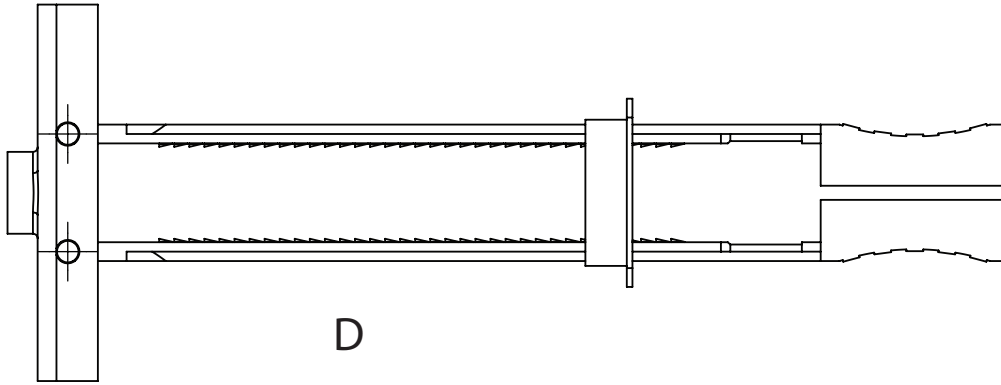

D

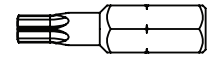

F

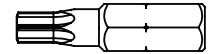

G



H

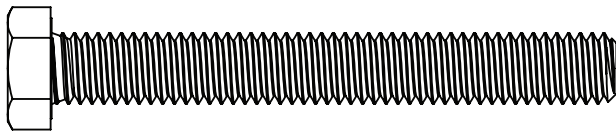

E

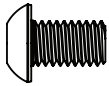

I



J

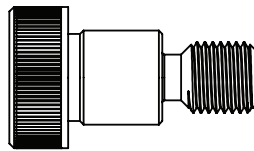

K

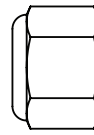

L

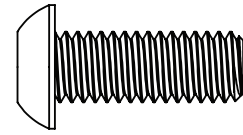

M

Part Description	Part Number	Quantity
A - #14, 3" Long SMS	11201069	8
B - 3/4" Flat Washer	AO52	8
C - Alligator Anchor	11300194	8
D - Snap Toggle Anchor	11201653	8
E - 3" Long Hex Head Bolt	11201654	8
F - T25 Bit	11201650	1
G - T27 Bit	11201651	1
H - T45 Bit	11201652	1
I - M6 x 1mm x 10mm - Bolt for Pivot Covers	11201643	4
J - M5 x .9mm x 8mm - Bolt for Wire Cover	11201609	3
K - Tray Shoulder Bolt	11201460	4
L - Nylon Locknut	11201461	4
M - 3/8" - 16 x 1" Security Torx Bolt	11201448	2



INCLUDED PARTS



N



O

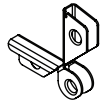

P

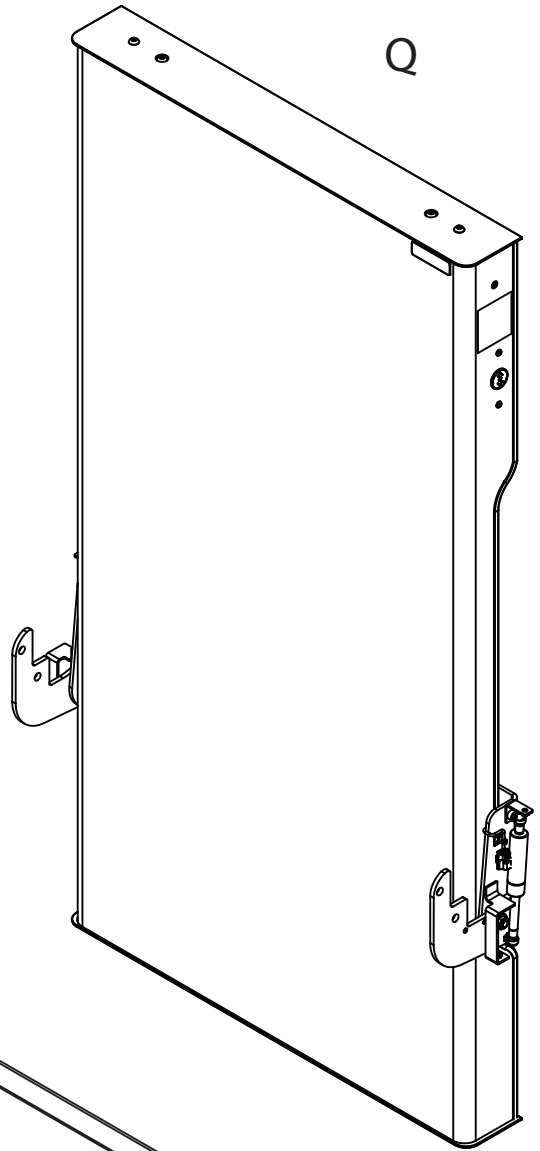

Q

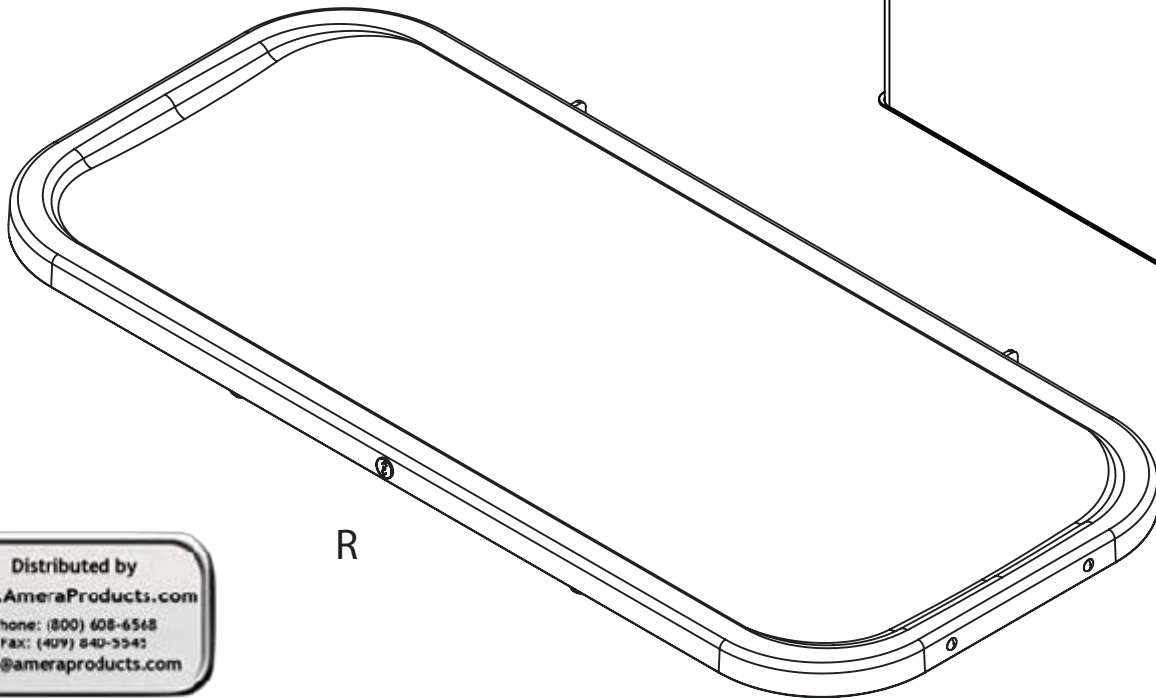

R

Distributed by
www.AmeraProducts.com
 Phone: (800) 608-6548
 Fax: (407) 840-9942
info@ameraproducts.com



Part Description	Part Number	Quantity
O - Right Hand Bracket Cover	11300181	1
N - Left Hand Bracket Cover	11300182	1
P - Wire Cover	11201606	1
Q - Wall Assembly	51100064	1
R - Tray	51100083	1

1A

Remove Torx Security bolts using T45 Bit (H).
Remove top cap.

Q x 1
H x 1

Retain for later steps.

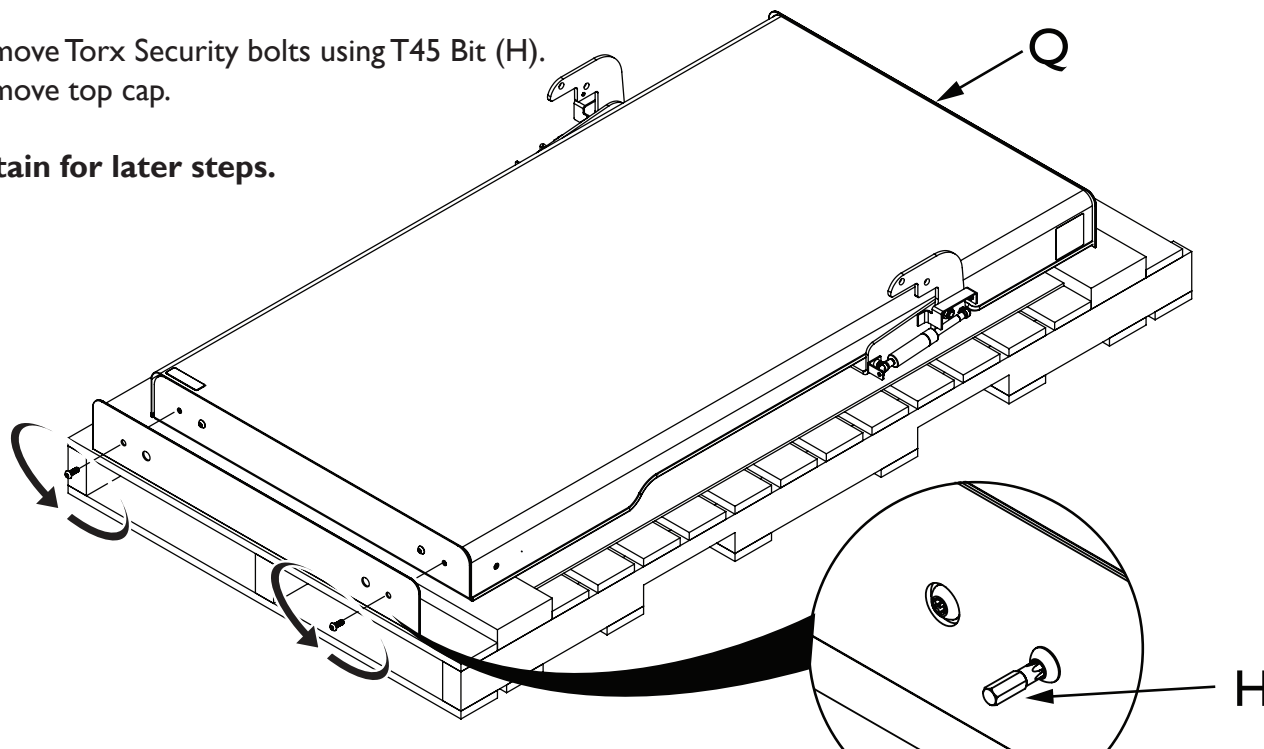

1B

Remove the shroud from "Q"
and place it to the side.

Retain for later steps.

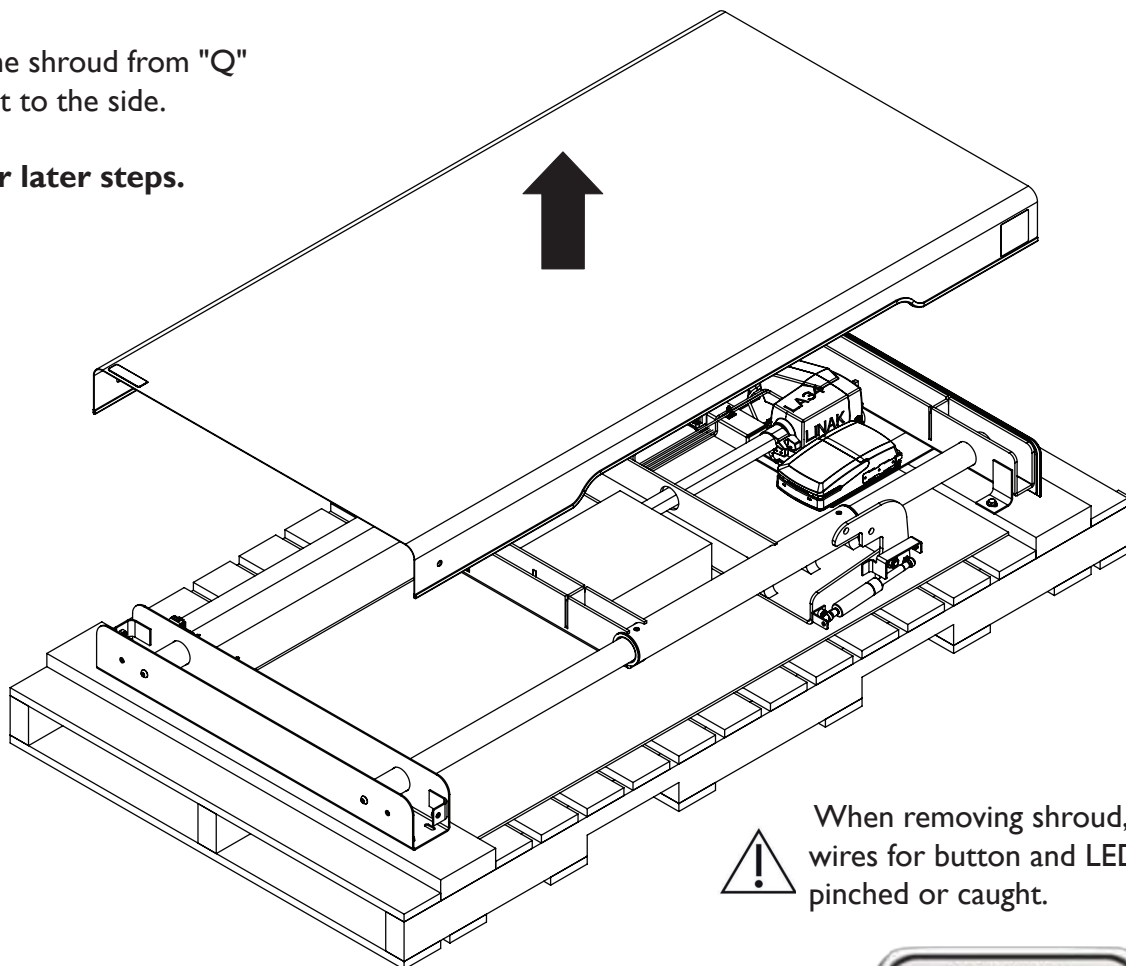

When removing shroud, ensure the wires for button and LEDs do not get pinched or caught.



2

Q x 1

Remove Hardware Box, Retain for Mounting and Step 14B.

Remove bolts and washers with 9/16" socket that fasten "Q" to the pallet, discard bolts and washers.

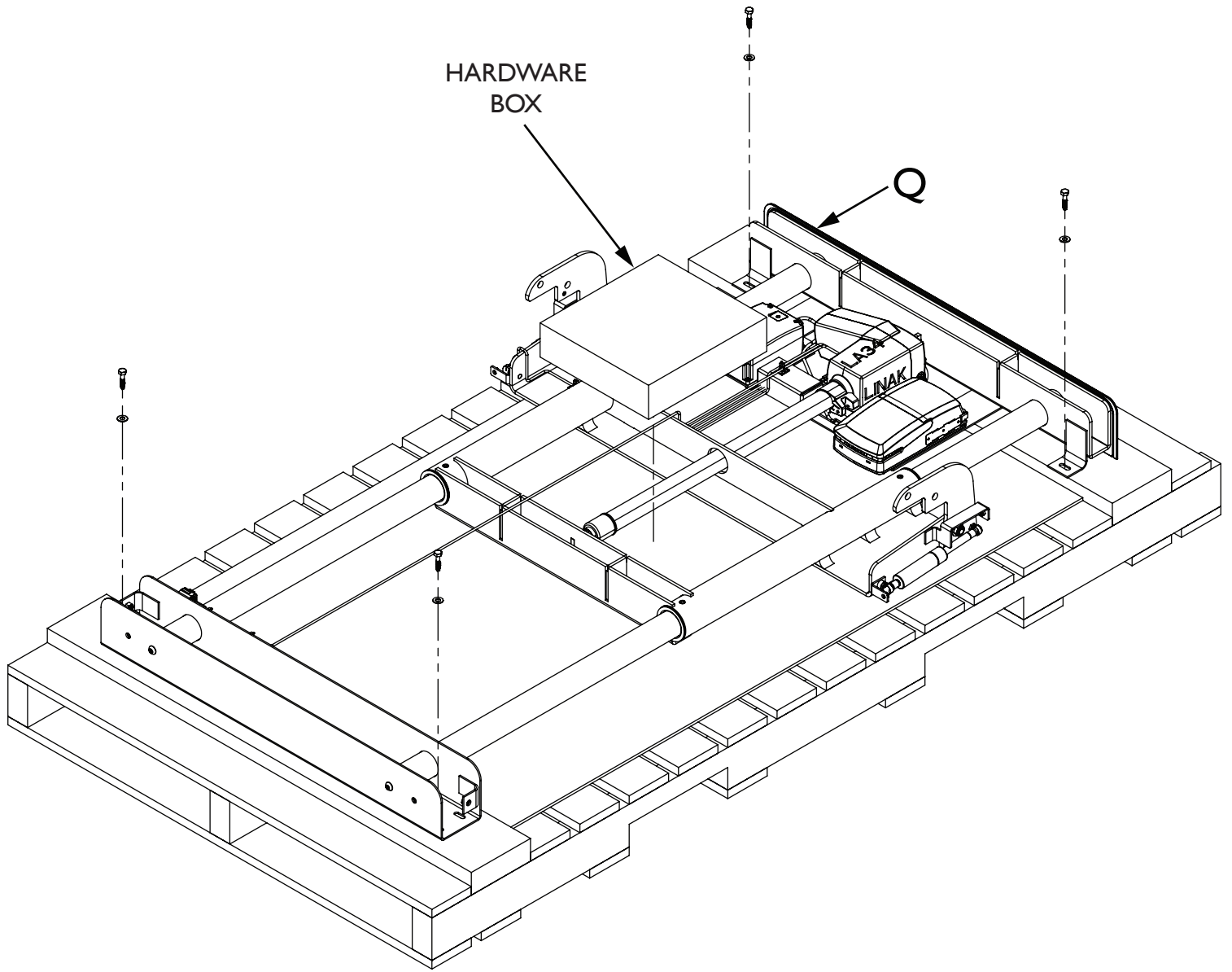

Distributed by
www.AmeraProducts.com
Phone: (800) 608-6548
Fax: (409) 640-5540
info@ameraproducts.com



3A

Locate and mark studs.

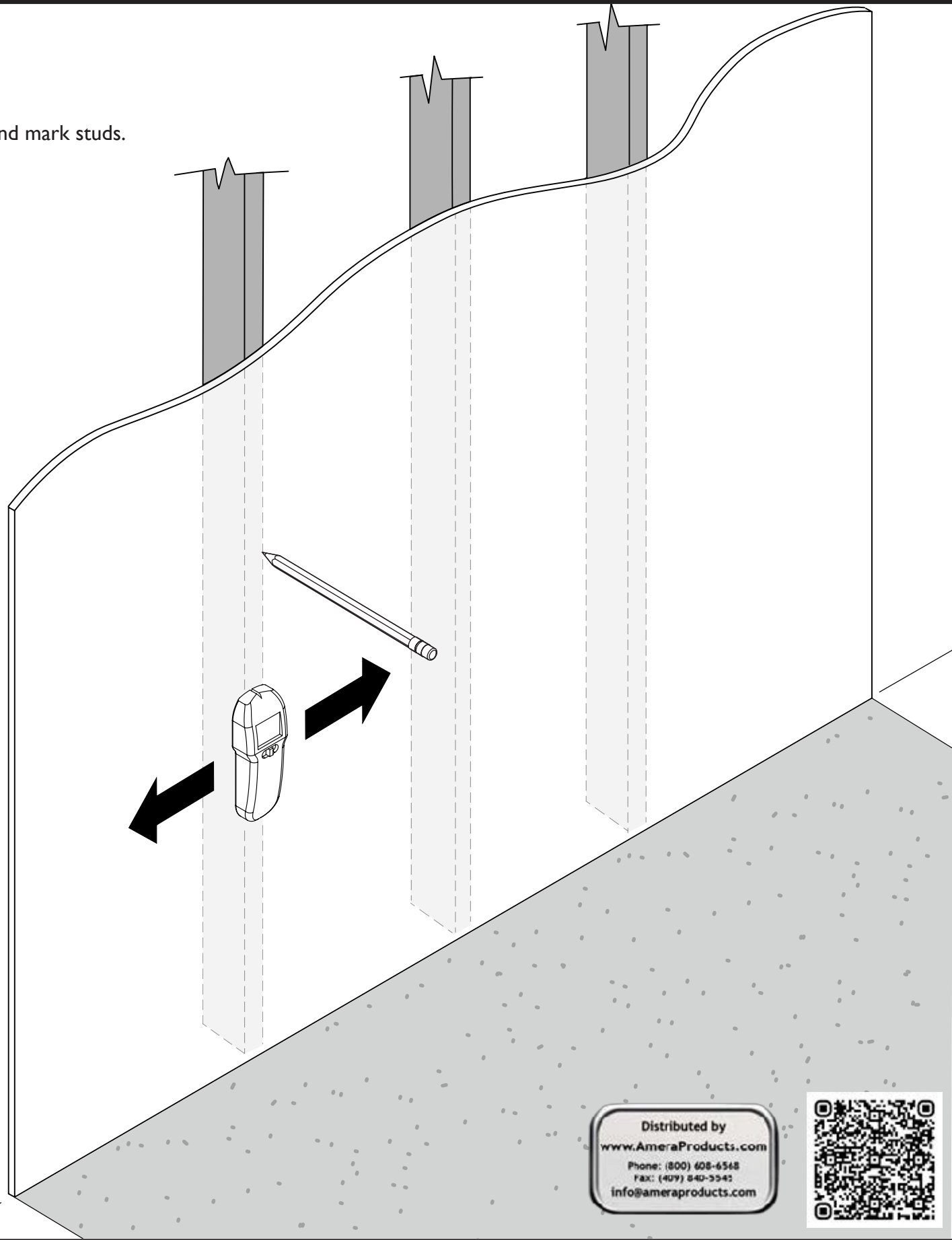

Distributed by
www.AmeraProducts.com
Phone: (800) 608-6568
Fax: (409) 840-5541
info@ameraproducts.com



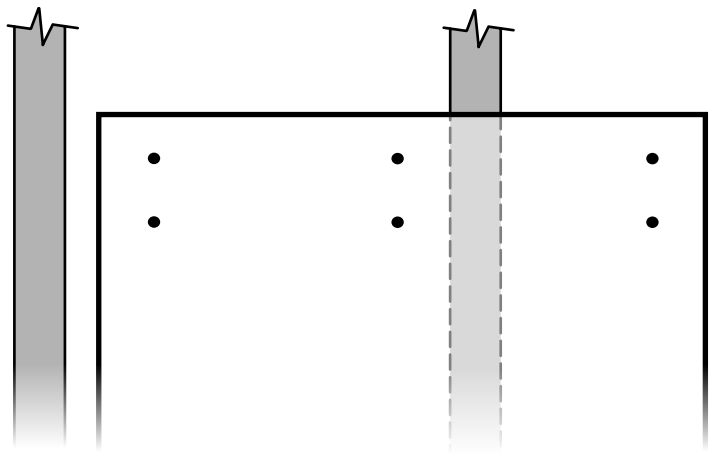
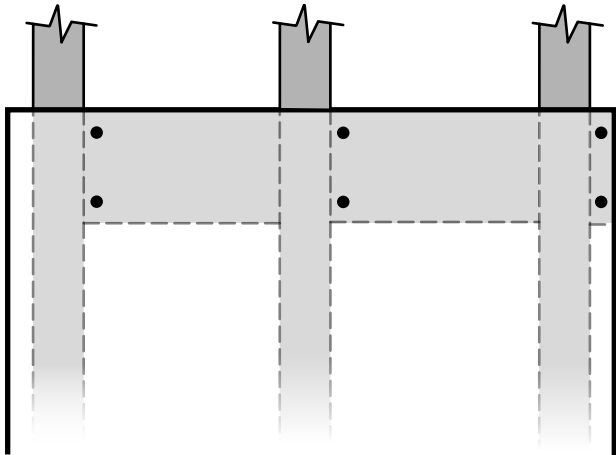
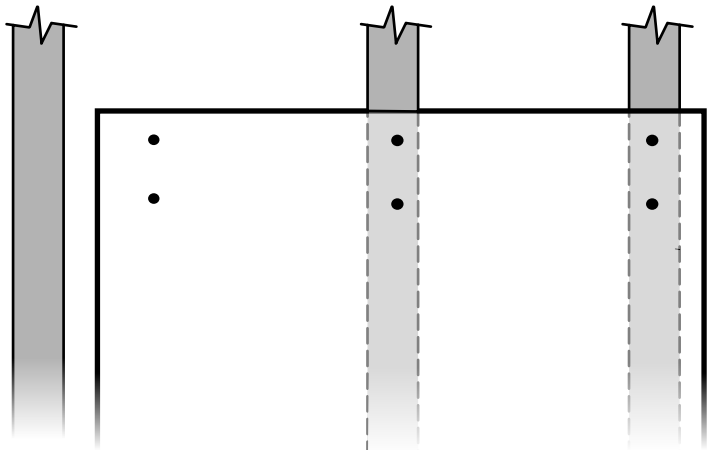
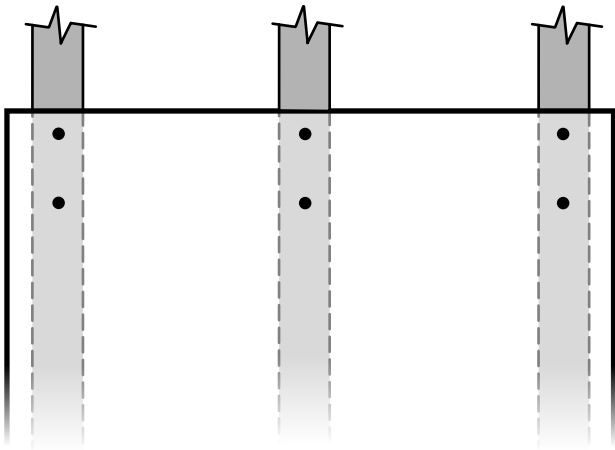

REMINDER - PLEASE REFER TO PAGES 5-6 ABOUT PRE-INSTALLATION REQUIREMENTS



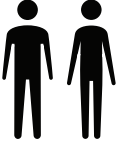

2 Align unit on marked stud location then mark 8 mounting holes.

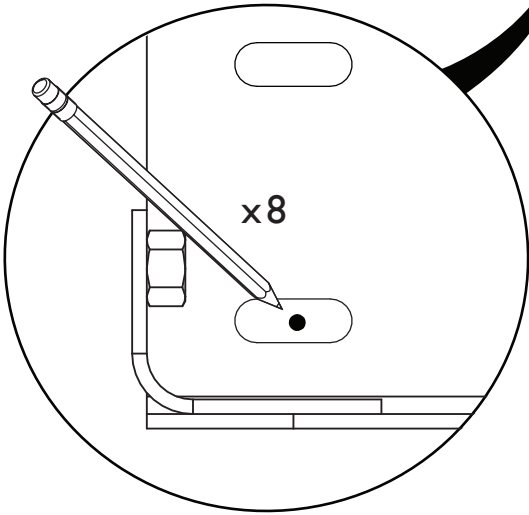

1 Level unit as needed with feet.

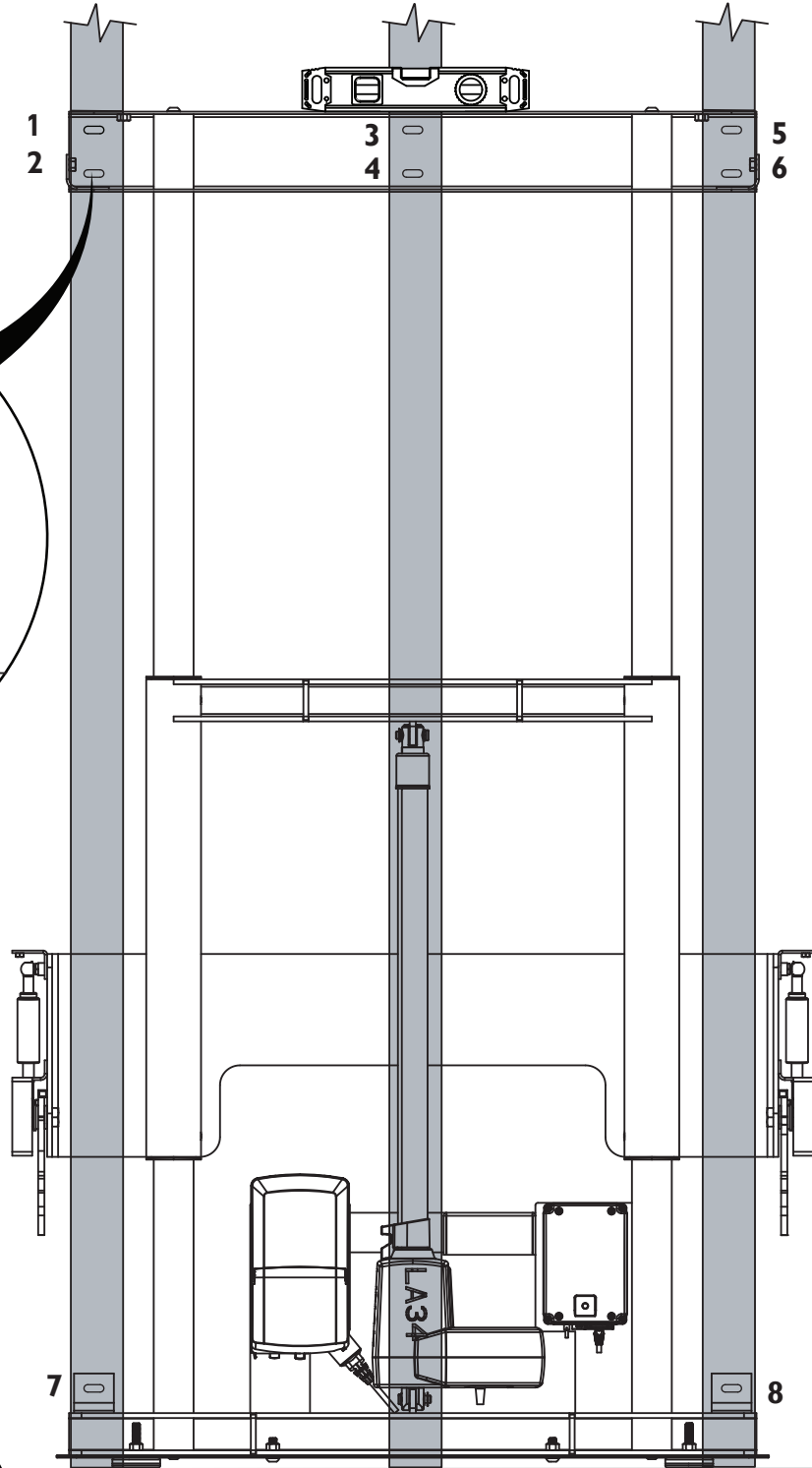
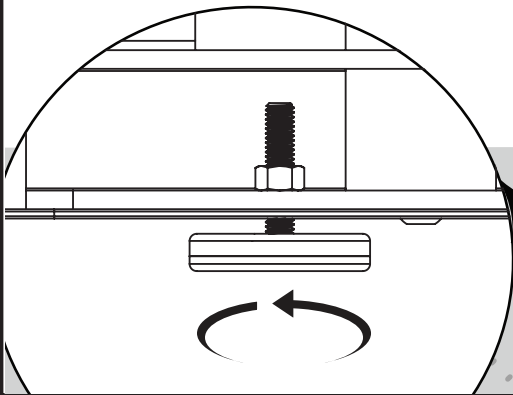

Distributed by
www.AmeraProducts.com
 Phone: (800) 608-6568
 Fax: (409) 840-5540
info@ameraproducts.com



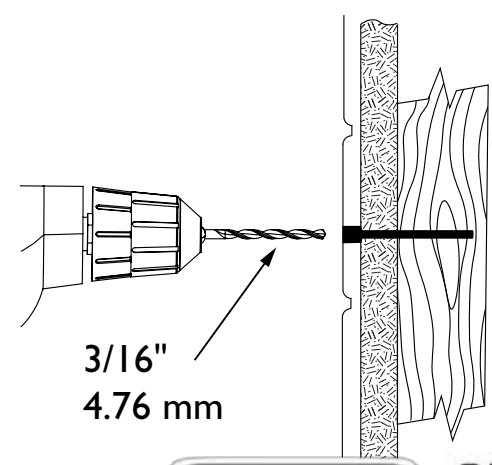
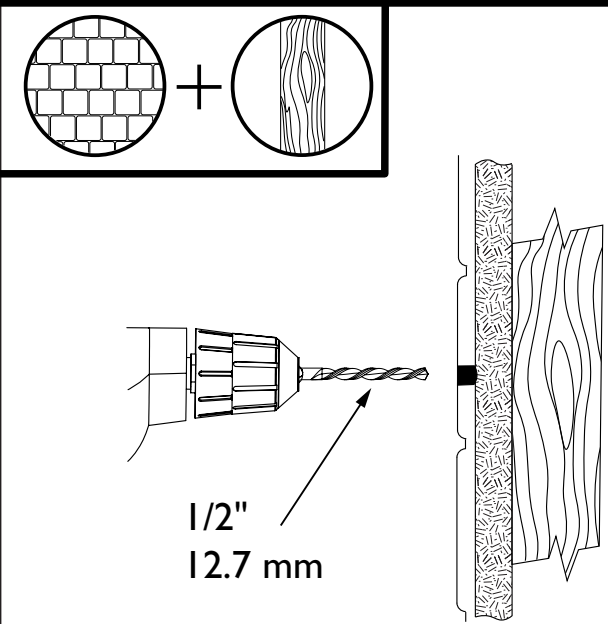
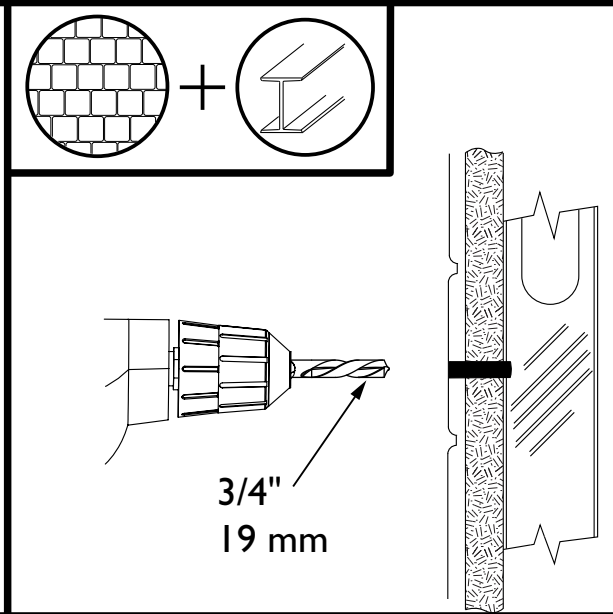
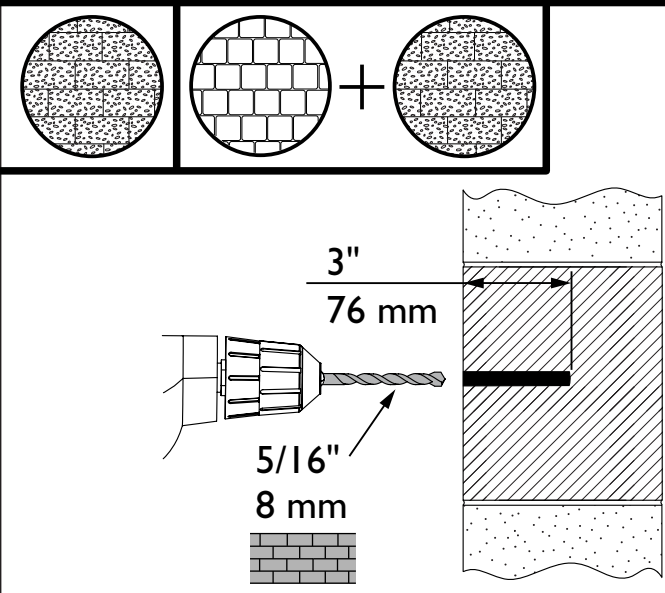
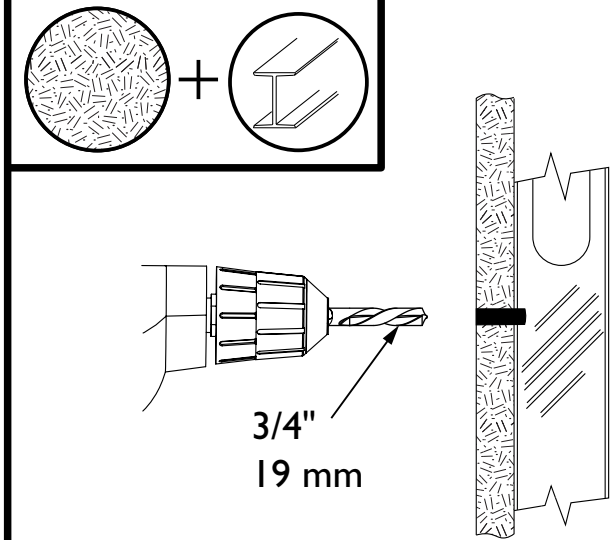
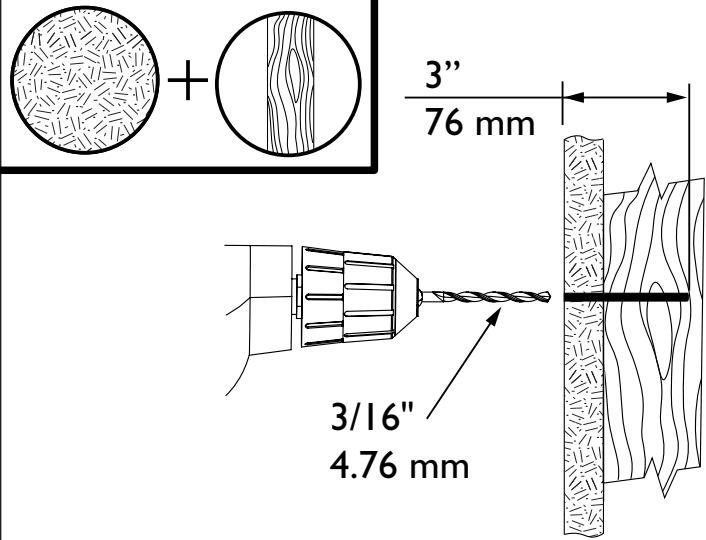

Distributed by
www.Ameraproducts.com
Phone: (800) 608-6548
Fax: (409) 640-5540
info@ameraproducts.com



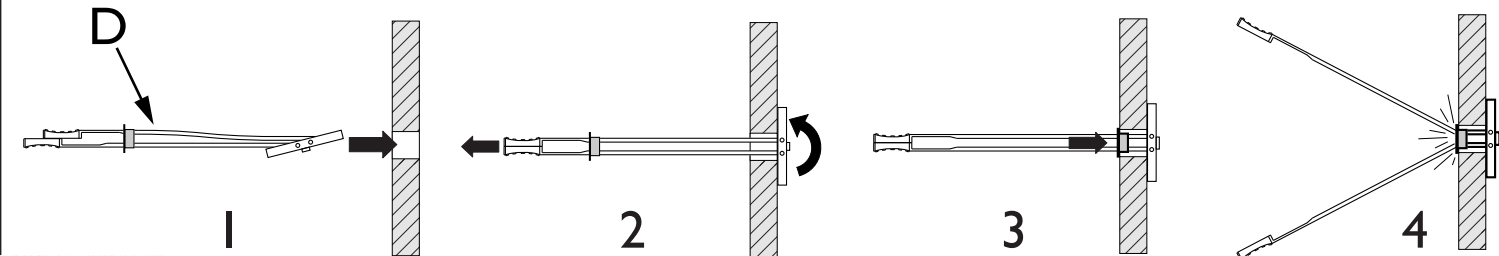
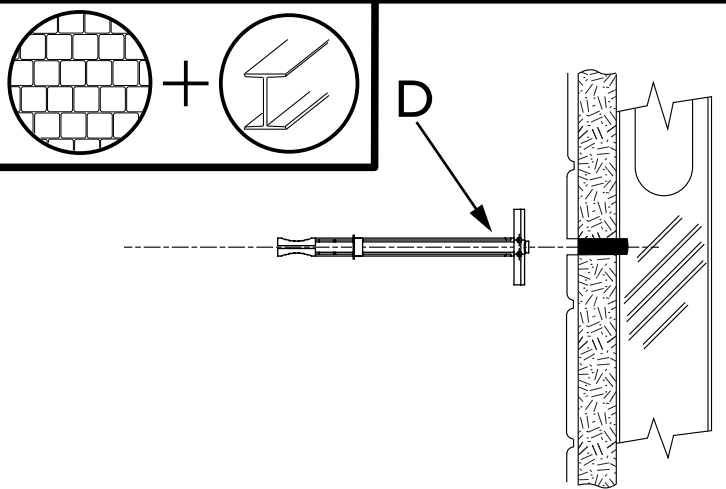
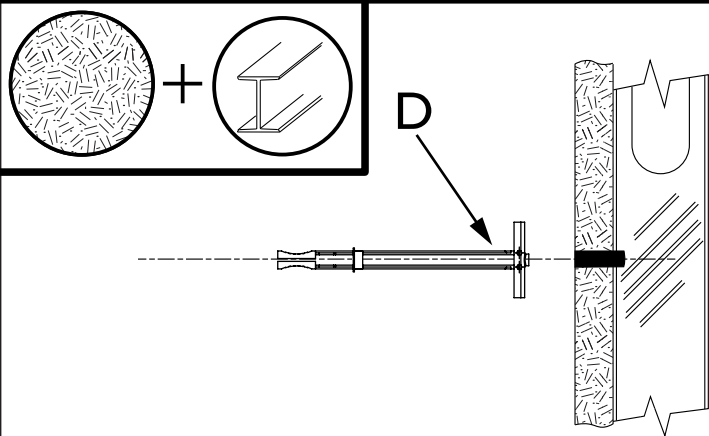
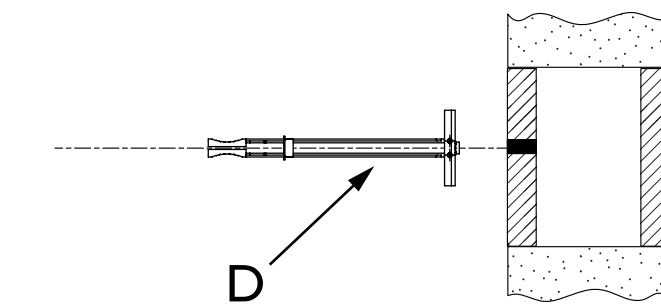
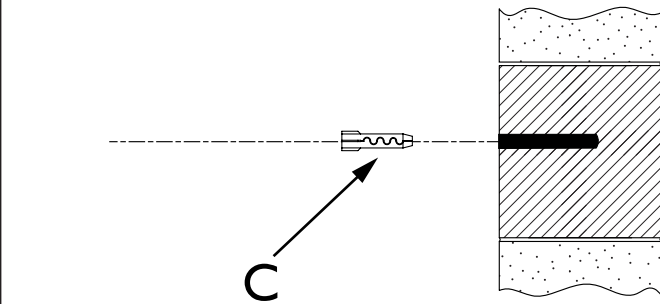
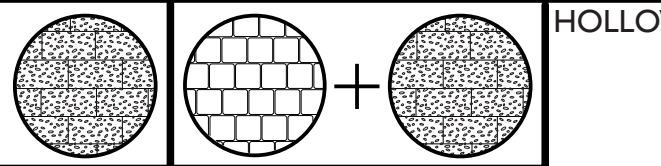
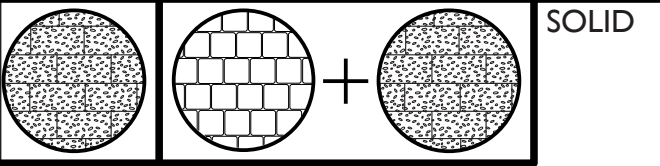
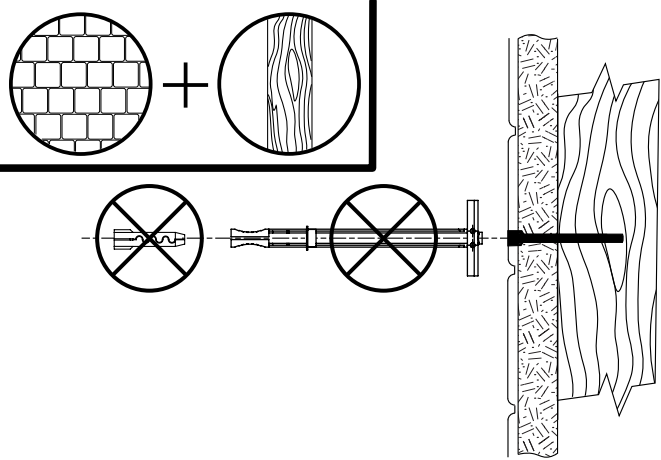
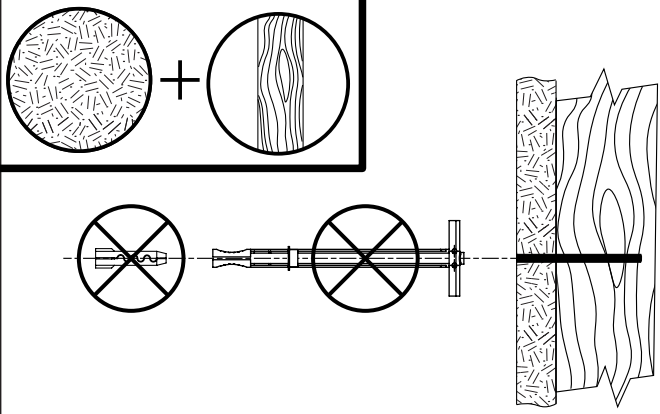

 DO NOT OVERTIGHTEN

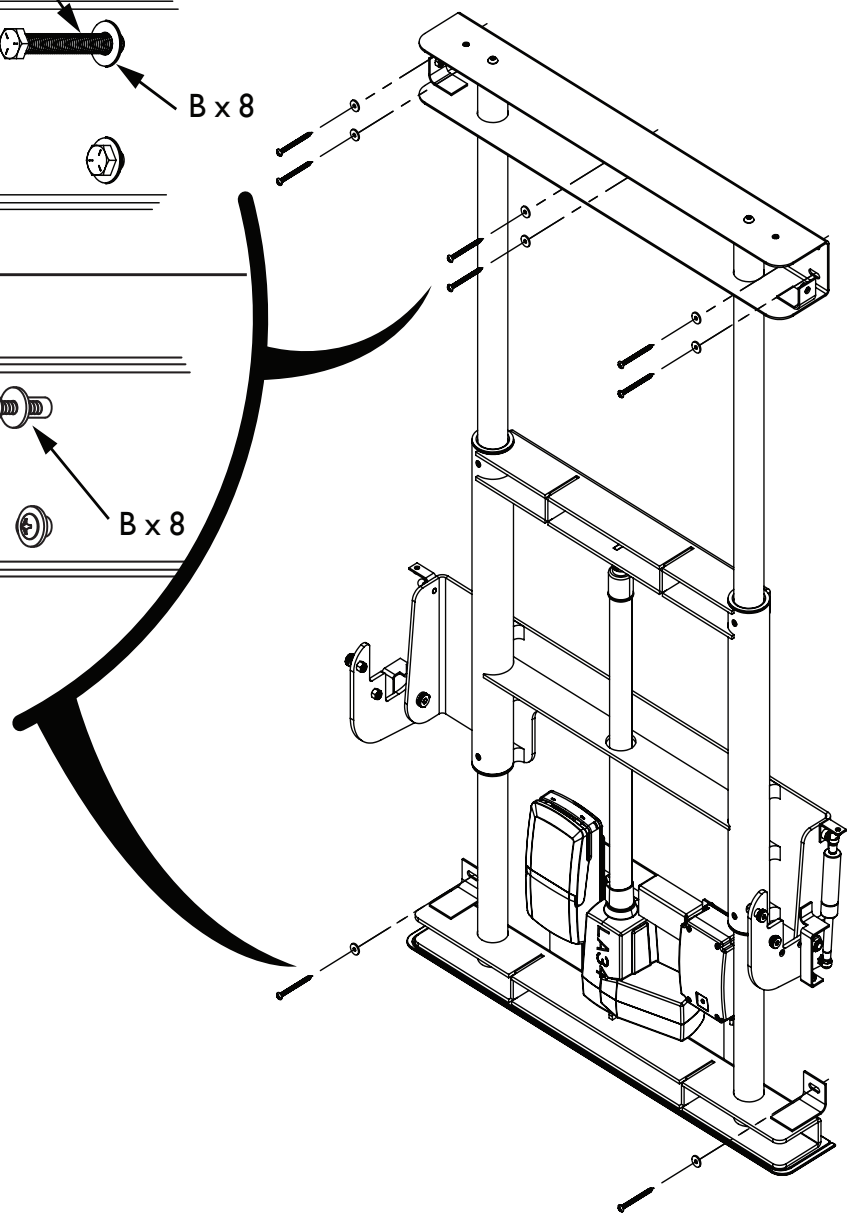
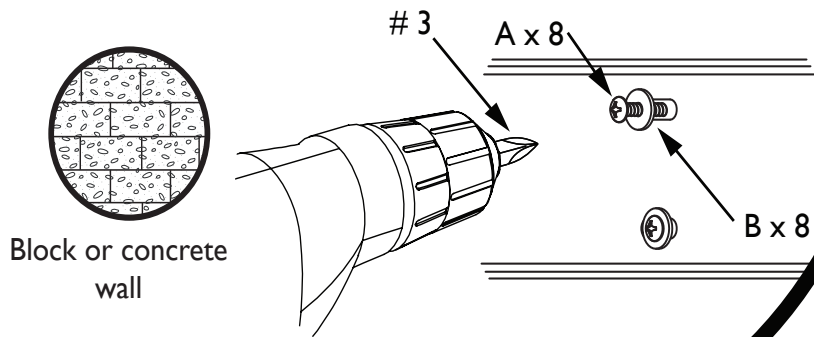
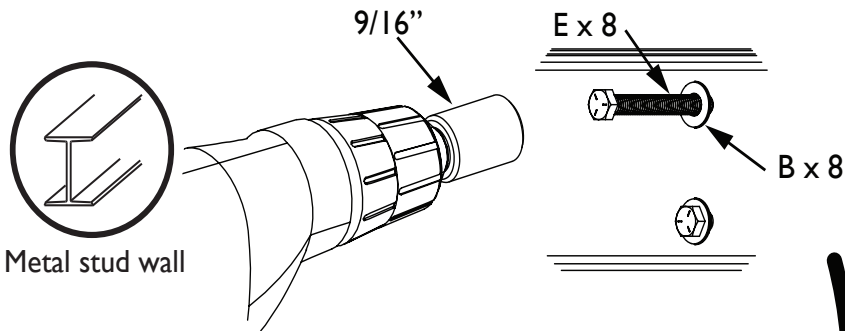
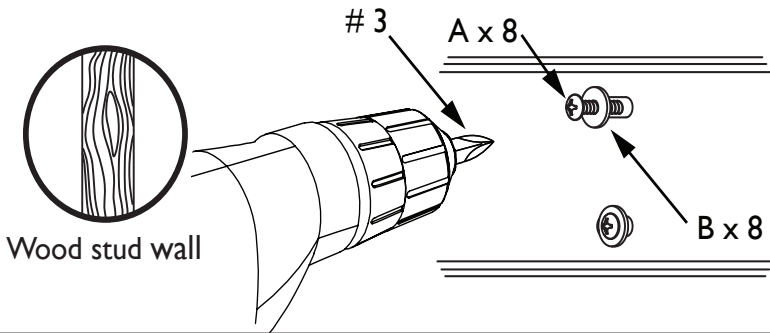

Distributed by
www.AmeraProducts.com
Phone: (800) 608-6548
Fax: (409) 840-5545
info@ameraproducts.com



WIRE UNIT INTO MAIN POWER

For more information, please see pages 7-8

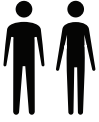

Q x 1

While holding the shroud, connect the 6 wire quick connectors near the top of "Q." Ensure wires are not pulled on to make connection, Do not let the shroud hang by the wire connection during assembly.

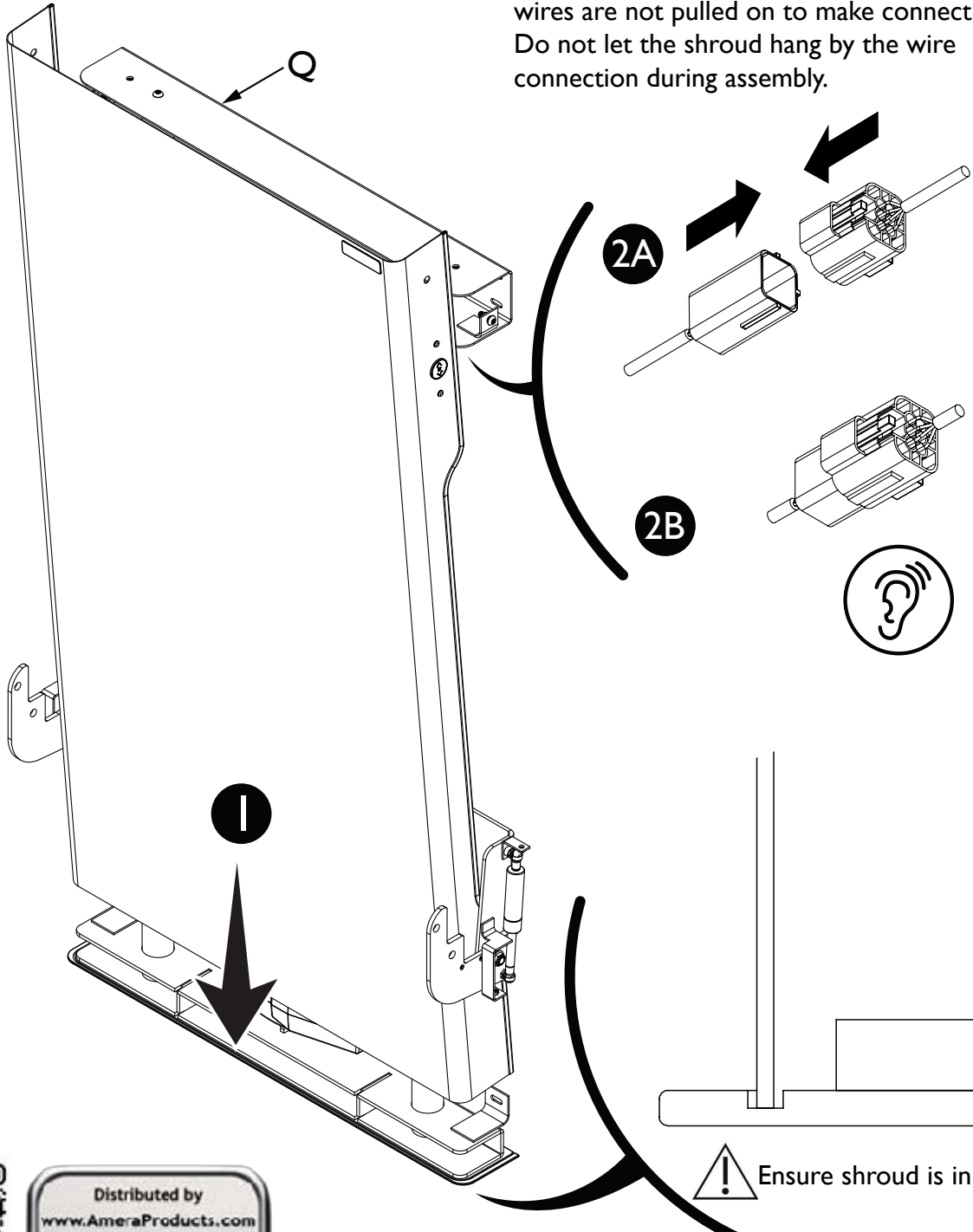

Ensure shroud is in nested in channel



Distributed by
www.AmeraProducts.com
 Phone: (800) 608-6548
 Fax: (409) 840-5542
info@ameraproducts.com

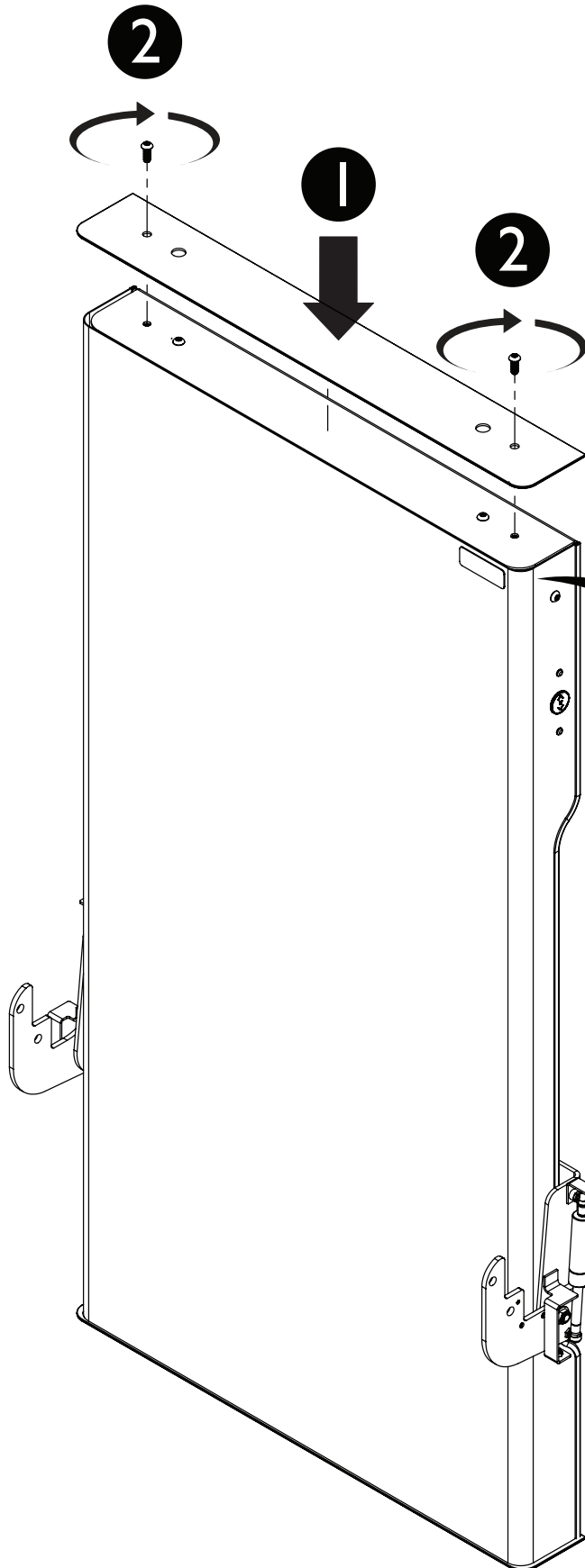

Secure Top Cap to "Q" using Torx security bolts (x2) removed from Step I using T45 bit (H).



Ensure shroud is seated inside groove in cap

Distributed by
www.AmeraProducts.com
Phone: (800) 608-6568
Fax: (409) 840-5545
info@ameraproducts.com



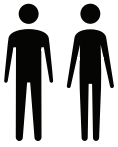

M x 2
H x 1

Secure Shroud to "Q" using Torx security bolts (x2).

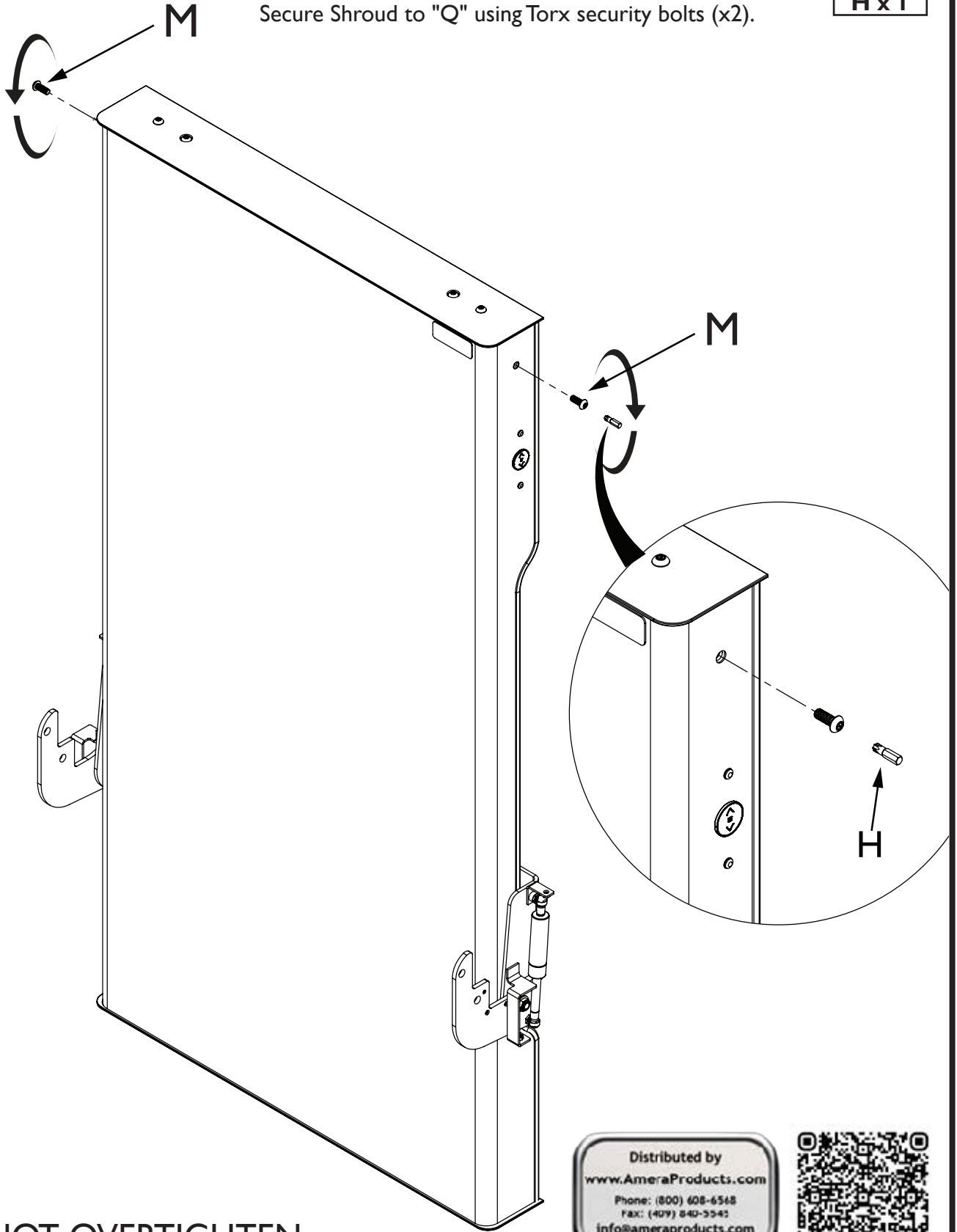

DO NOT OVERTIGHTEN

Distributed by
www.AmeraProducts.com
Phone: (800) 608-6548
Fax: (409) 840-5542
info@ameraproducts.com



12A

R x 1

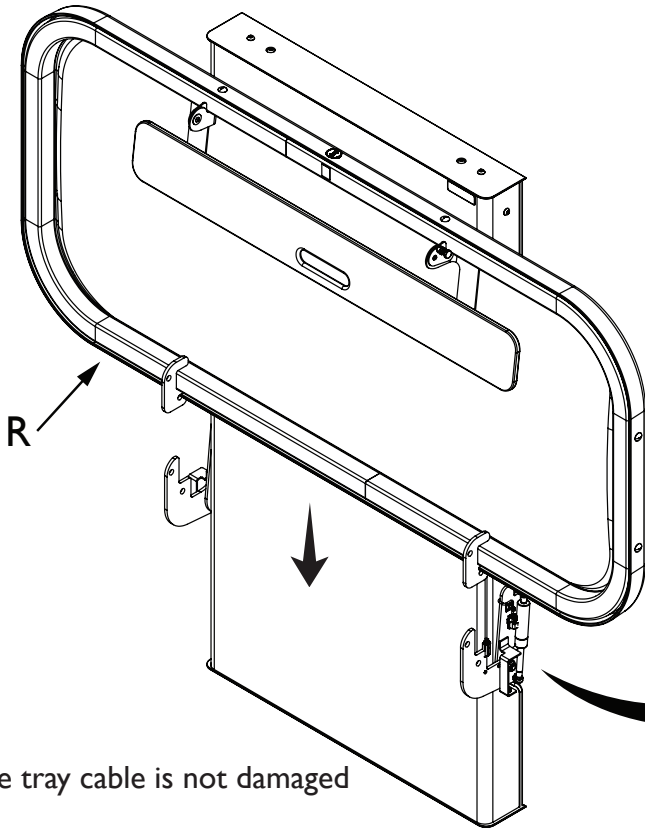
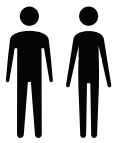

Ensure "Q" arms are inside "R" bracket

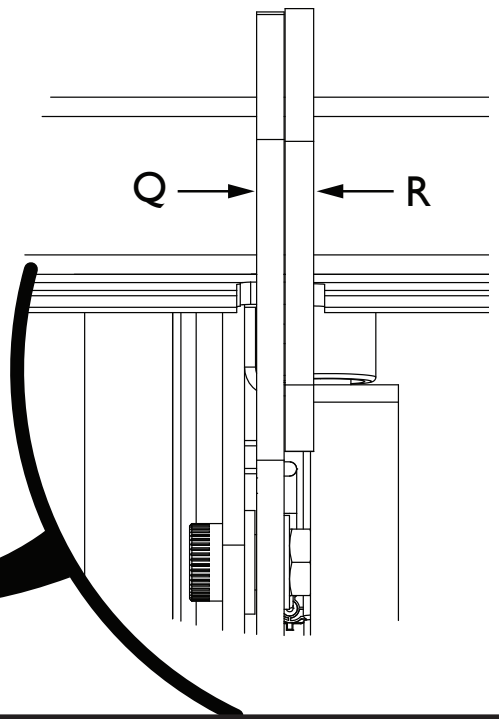

Ensure tray cable is not damaged

12B

K x 4
L x 4

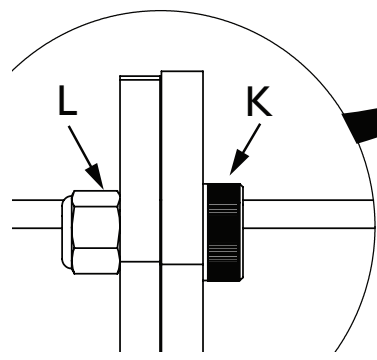
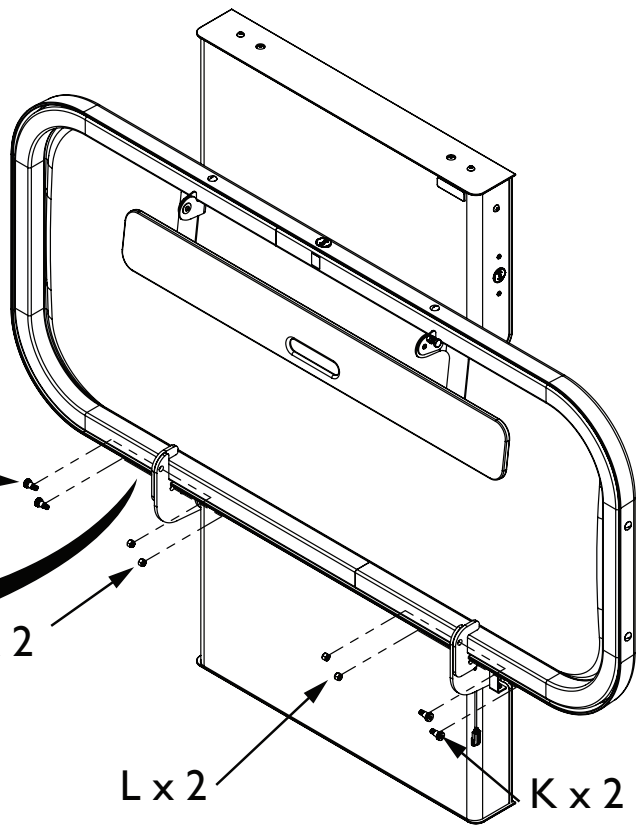
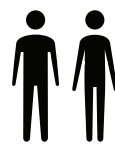

Distributed by
www.AmeraProducts.com
Phone: (800) 608-6548
Fax: (409) 840-5545
info@ameraproducts.com



13A

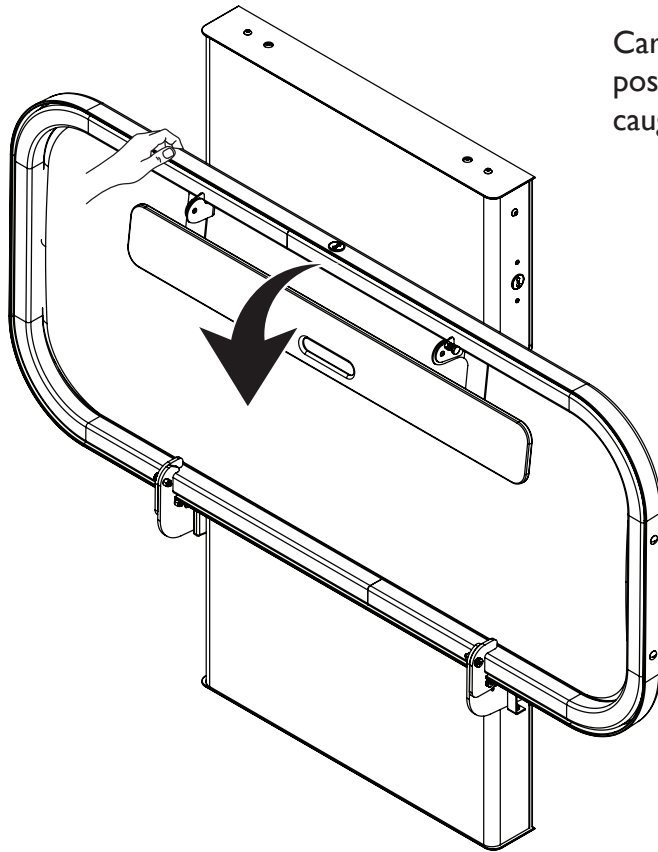

Carefully open tray to in use position, ensuring no wiring gets caught or pinched.

13B

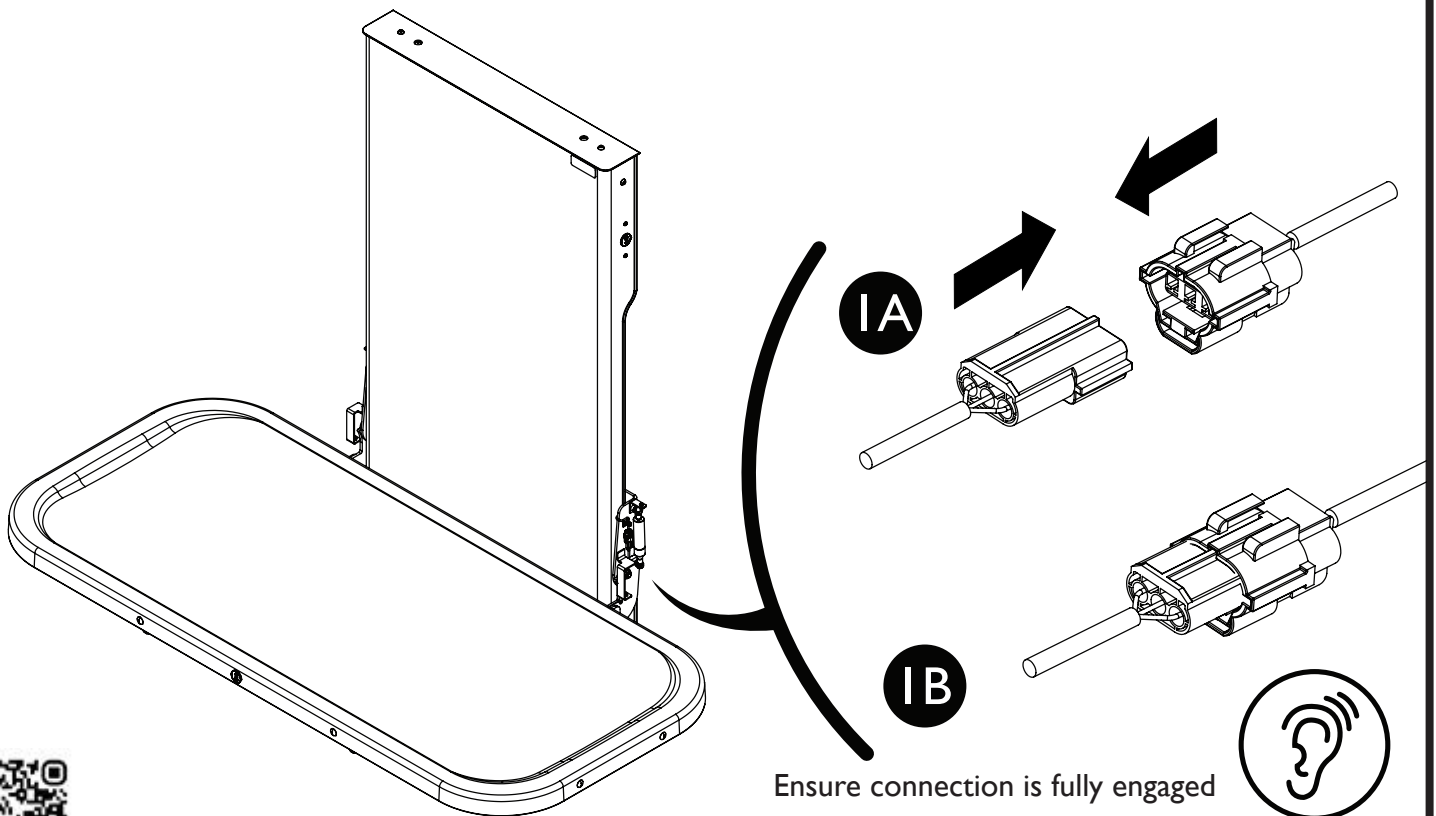

Ensure connection is fully engaged



14A

WIRE
ROUTING

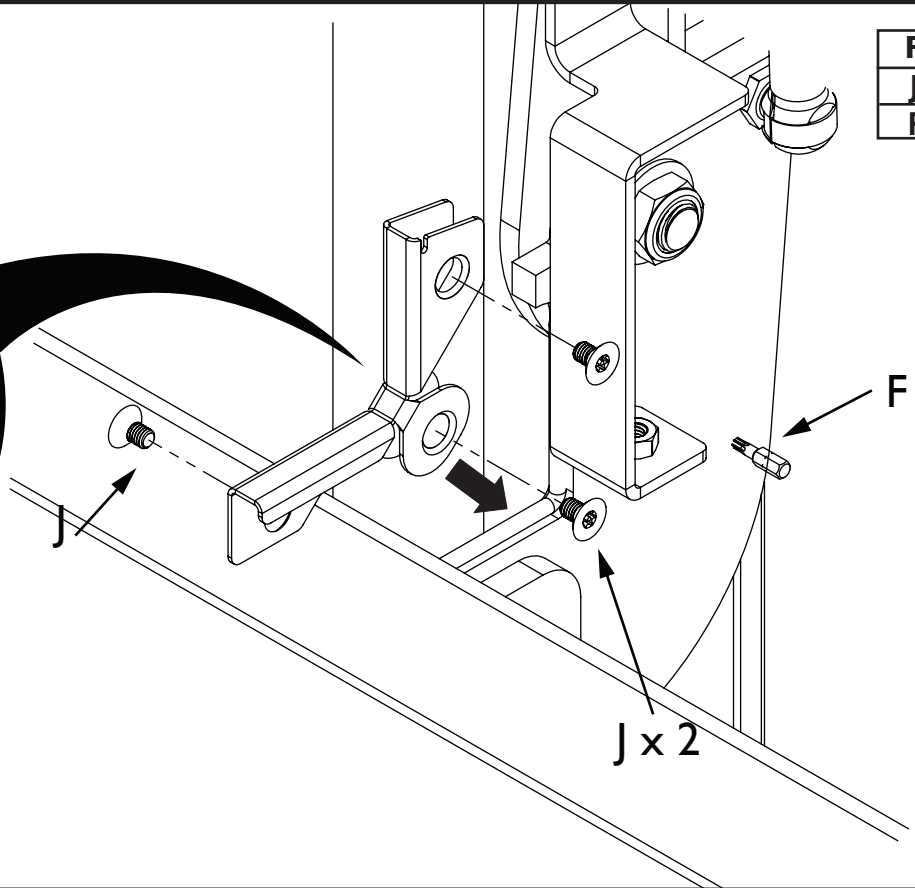

P x 1
J x 3
F x 1

14B

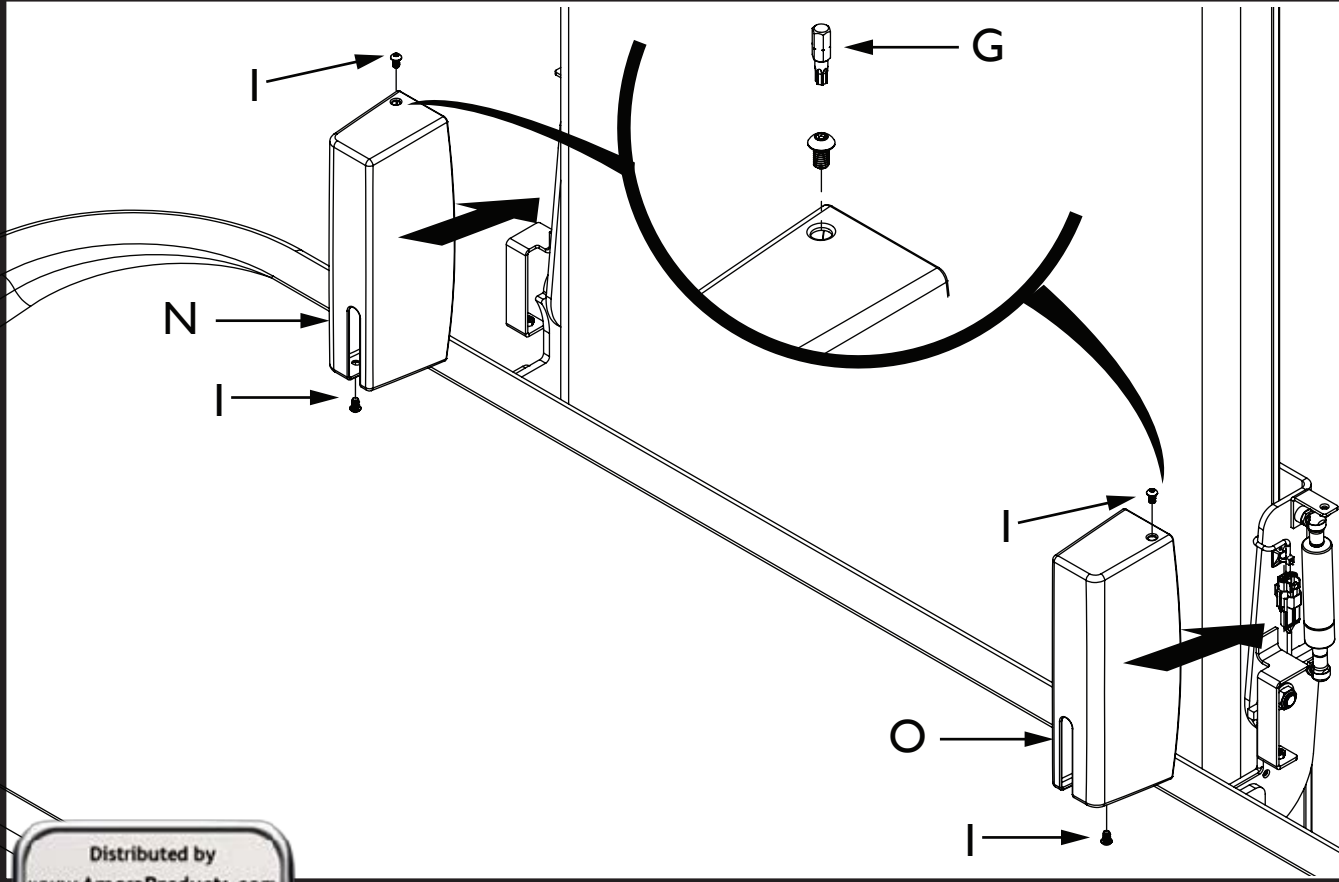

N x 1
O x 1
L x 4
G x 1

Distributed by
www.AmeraProducts.com
 Phone: (800) 608-6568
 Fax: (407) 840-5542
info@ameraproducts.com



CHECK FUNCTIONALITY



Move tray up and down at least 2 times, using EACH button. QR code shows video tutorial of button locations and how to use product.

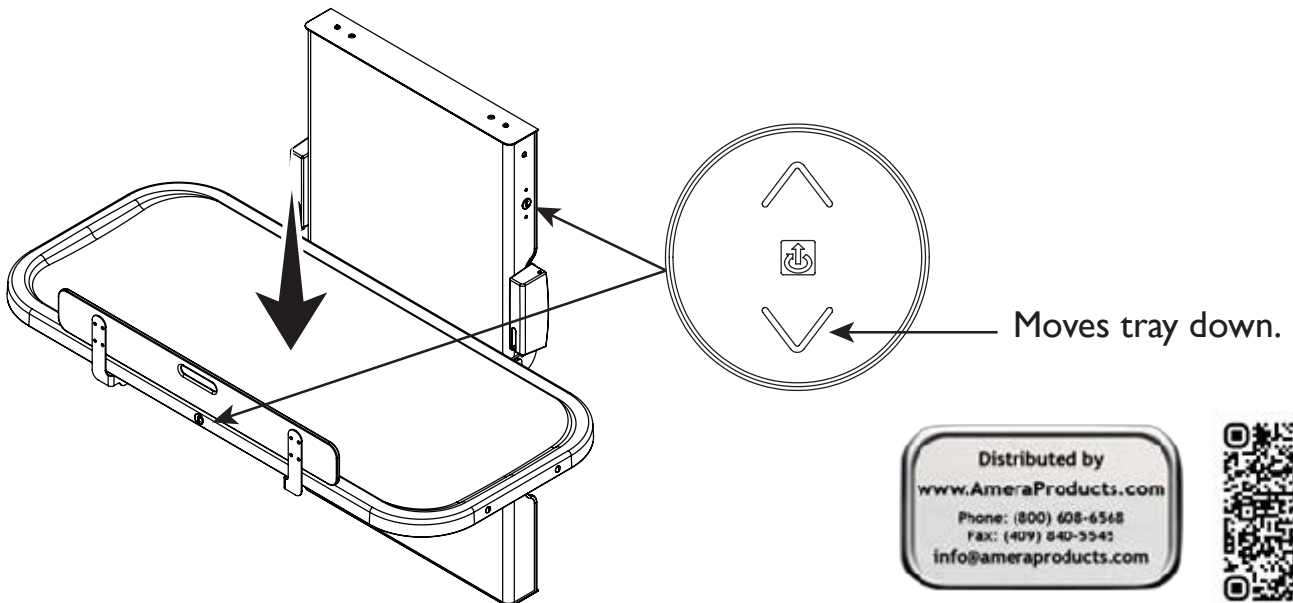
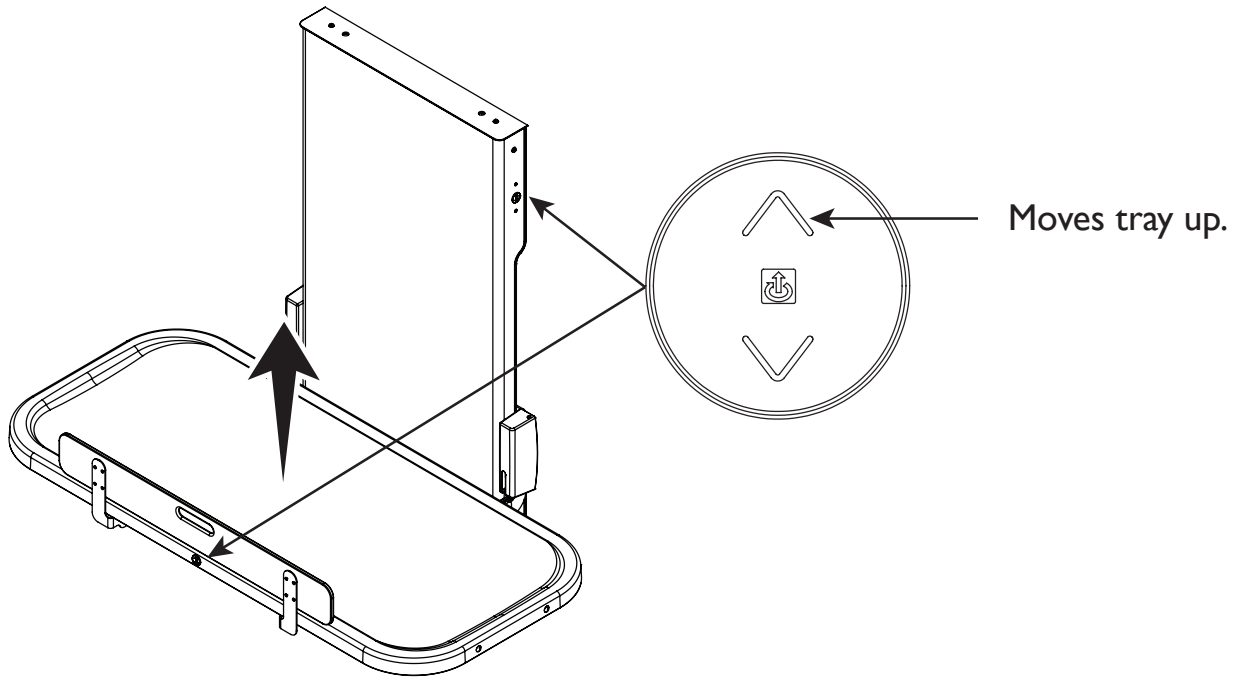

Distributed by
www.AmeraProducts.com
Phone: (800) 408-6548
FAX: (409) 840-5542
info@ameraproducts.com



GUARD

1 Hold guard rail.

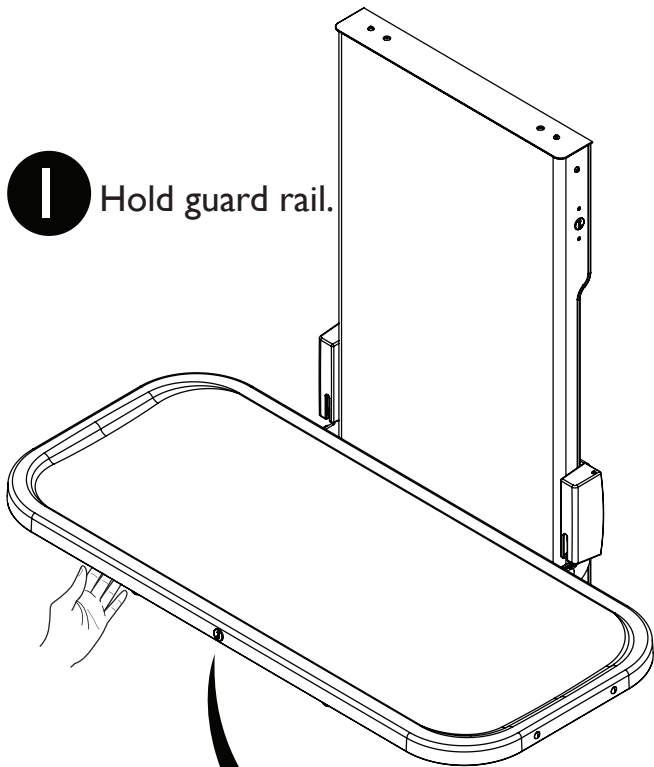

3 Rotate guard rail.

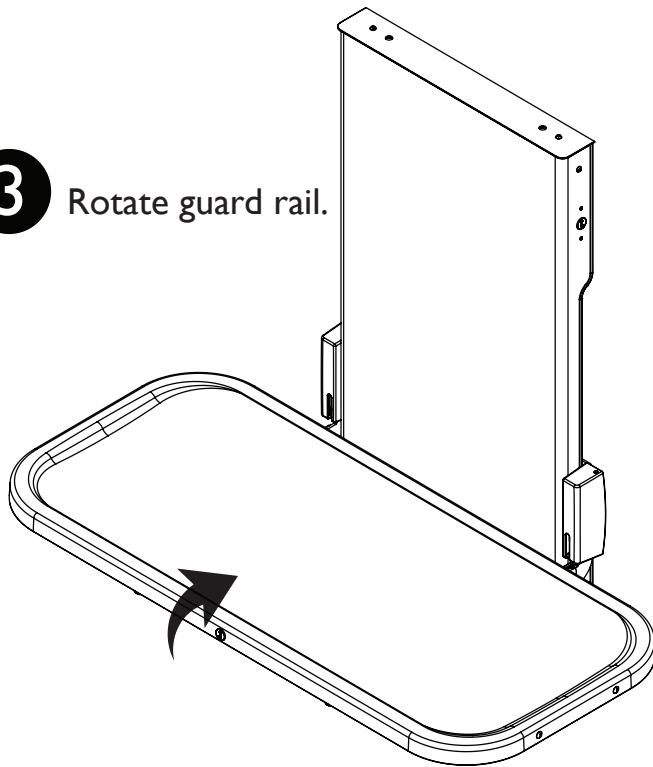

2 Pull out plunger.

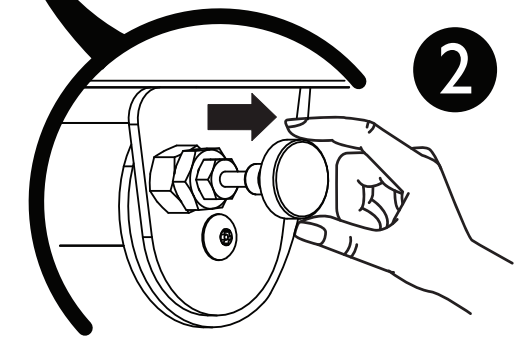

Listen for click

4 Release plunger

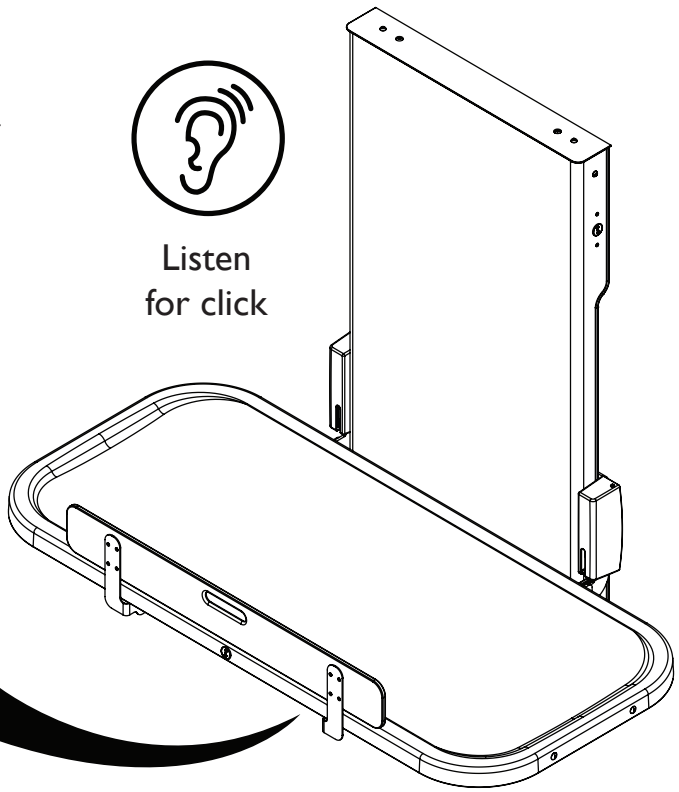
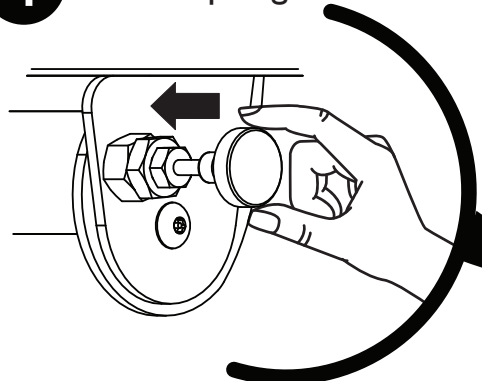

INDICATOR LIGHTS



If lower red light is illuminated,
DO NOT USE!



If upper green light is illuminated,
charging and ready to use.



If no lights are illuminated,
safe to use.

Distributed by
www.Ameraproducts.com
Phone: (800) 608-6568
Fax: (409) 840-3541
info@ameraproducts.com



TROUBLESHOOTING (FAQ)

 **CAUTION** Troubleshooting requiring access to enclosed internal components should be addressed for use by licensed professionals only.

Q: Why are the tray/shroud button(s) not functioning?

- A: Tray Button: Refer to steps 9 & 10, ensure connectors are pushed together and engaged all the way.
- A: Shroud Button: Refer to steps 13B and 14B, ensure connectors are pushed together and engaged all the way.
- A: Check PCB Connection to loom near the bottom on the tower assembly, location shown in Figure 1. Ensure that the white PCB loom is pressed up against PCB, location shown in Figure 2.

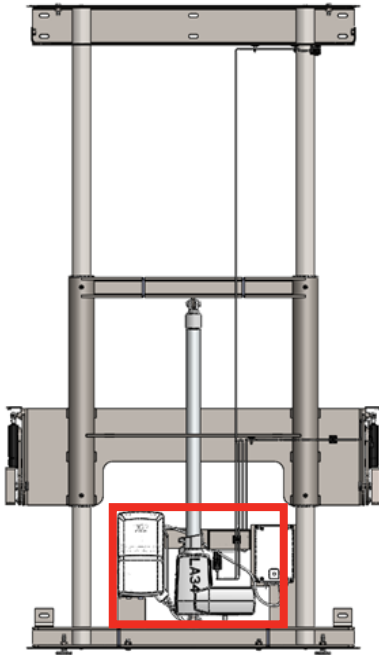

Figure 1 Location of PCB Loom and Connectors

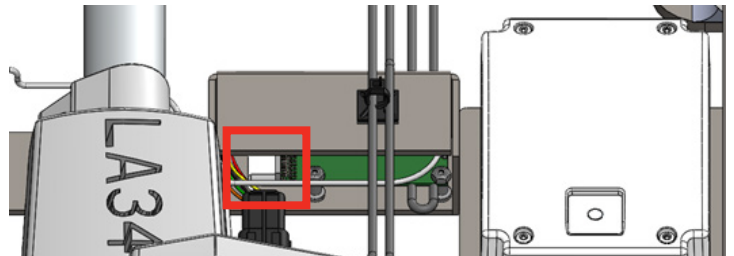

Figure 2 Location of PCB Loom.

Being careful not to pull on wires, ensure that the connectors from the loom to harness are pushed together and engaged all the way, location shown in Figure 3.

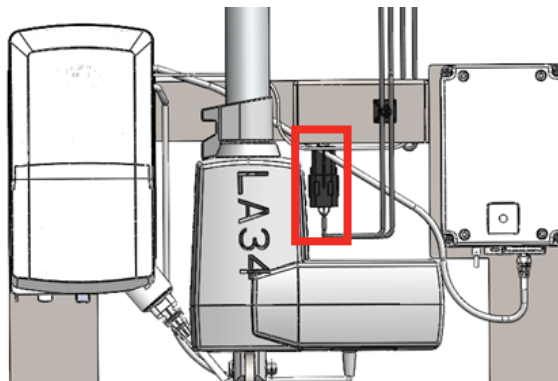

Figure 3 Connectors pressed together



Contact Technical Support if the issues are not resolved.

TROUBLESHOOTING (FAQ)

Q: Why are the LEDs not functioning?

- A: The Green LED will only be lit up when charging the battery backup. The Red LED will only light up when battery backup is at low power. If still have issues during those situations, call Technical Support.

Q: Why is the Tray Assembly not fully opening or closing?

- A: Ensure that there are no objects inside the covers that are interfering with movement of the tray assembly.

Q: Guard will not stay latched.

- A: Ensure that plunger is present and functions properly. If not present, take the unit out of service and call Customer Service.
- A: Ensure that there are no obstructions for in the location holes on the guard mounting arm are clear.
- A: Rotate Guard into a locking location to check if the Guard will lock in place. If still have issues during those situations, call Technical Support.

Q: Why is my unit beeping at a steady rate when moving up or down.

- A: The steady beeping means that the actuated system needs to relocate the minimum and maximum travel. Move tray to the highest position then to the lowest. If the beeping persists, call technical support.

Q: Why and how do I reset the system?

- A: The reason a system reset is required if the system will does not stop steadily beeping at a steady rate.
- A: To reset the system, hold the up and down button on either the tray or the tower for 5 seconds.



CLEANING

For cleaning the tray and guard:

- Wipe down the using a damp cloth with mild soap or multi-purpose cleaner. Do NOT use any strong chemical cleaners or cleaning agents that may be hazardous.

For cleaning the stainless-steel shroud:

- Wipe down the using a damp cloth with mild soap or multi-purpose cleaner. Do NOT use any strong chemical cleaners or cleaning agents that may be hazardous.

For cleaning the vertical tubes:

- Wipe the vertical tubes from the inside the tower through the sides of the shroud, with a dry microfiber cloth as required. Move tray to lowest position and wipe tubes then move tray to highest position and wipe tubes

MAINTENANCE

Check all hardware and components monthly or as required to ensure all hardware is present and there are no damaged or missing components. Take unit out of service if any components or hardware are missing and contact Customer Service to order replacement parts. Do **NOT** substitute parts.

Distributed by
www.AmeraProducts.com
Phone: (800) 608-6568
FAX: (409) 840-5542
info@ameraproducts.com

