

Item # 432-1-BLK | Automatic Hands-Free Transparent Gel Hand Sanitizer/ Liquid Soap Dispenser, 700 mL, BLACK

PARTS LIST	STEP 1 Use the mounting plate as a template to mark the position where you want to install the unit	STEP 1 Drill two 5mm holes into the mounting area and insert anchors into the holes	STEP 3 Fasten the mounting plate to the wall with the provided screws
 Distributed by www.Ameraproducts.com Phone: (800) 608-6568 Fax: (409) 840-5545 info@ameraproducts.com	STEP 4 Carefully slide the dispenser in the mounting plate	STEP 5 Open the lid and fill the unit with sanitizing contents	STEP 6 Place your hand beneath the sensor of the unit and test
			

Item # 432-1-BLK | Automatic Hands-Free Transparent Gel Hand Sanitizer/ Liquid Soap Dispenser, 700 mL, BLACK

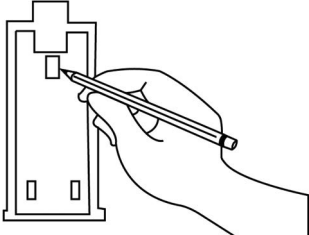
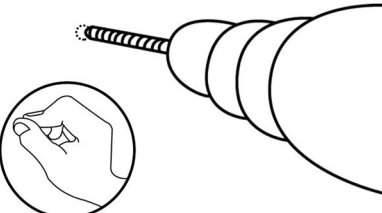
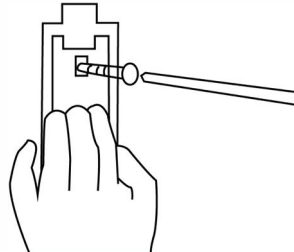
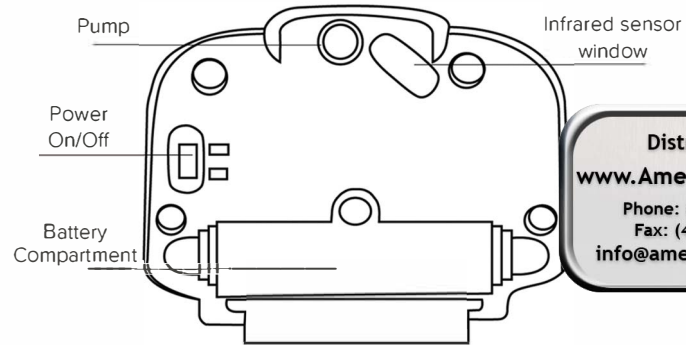
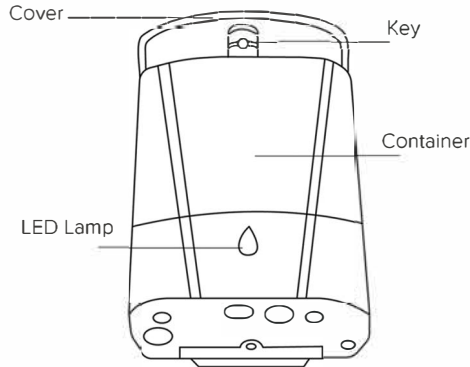

Distributed by
www.Ameraproducts.com

Phone: (800) 608-6568
Fax: (409) 840-5545
info@ameraproducts.com

FEATURES & INSTALLATION NOTES

1. Do not install the dispenser above a mirror surface or above flowing water
2. Do not install the dispenser within less than 2" (50cm) height beneath a table
3. The sensor is at the base of the dispenser. The range of effect is from 0-4" underneath the sensor.
4. The unit is designed for indoor use only. Direct sunlight or exposed locations can destroy the infrared sensor of the product
5. Low voltage indicator: Flashing LED light on the Dispenser while on standby means the batteries must be replaced
6. Do not use the alcohol or other chemical liquid.
7. This product doesn't have waterproof function, do not submerge or place near water.

MAINTENANCE OF THE UNIT

1. If there is dust inside the container, clean the container and before refilling with sanitizer.
2. Clean the unit's surface with a wet towel & use a dry towel to clean the battery compartment.
3. When not in use, fill the container with water and switch on the dispenser several times to clean the pipe. Be sure to take out the batteries.
4. If the contents have congealed, fill it with some warm water and wait a few minutes before operating. Operation will push out the water.

IF UNIT DOESN'T WORK

1. Check the battery whether the power has been used up or not inserted incorrectly
2. Check to see if power is switched off

IF UNIT IS NOT DISPENSING

1. You must operate the dispenser several times when you first use it.
2. The liquid will congeal in the winter, you will need to fill it with warm water.
3. Check if Dispenser needs to be refilled

SPECIFICATION

MODEL	
OUTER SIZE	L110*W100*H165MM
CAPACITY	700ml
DROP VOLUME	0.8-1ml
WEIGHT	480g
MATERIAL	ABS, AS
BATTERY	4X1.5V "AA"

TECHNO - PARAMETER

ELECTRICAL SOURCE VOLTAGE	DC6V
STATIC CURRENT	60UA
WORKING CURRENT	200MA
POWER	4W
EFFECT DISTANCE	0-10CM