

Sanitary Liner Dispenser KB134-SSLD

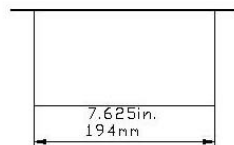

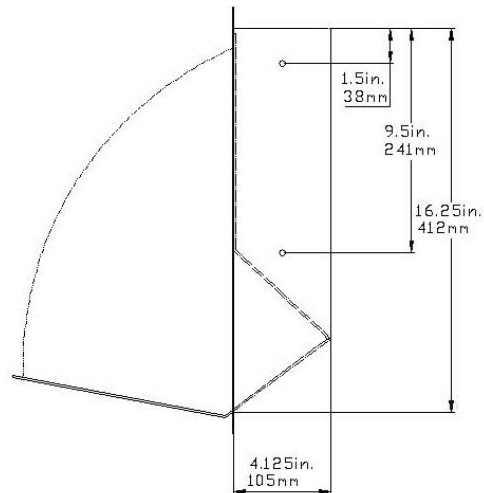
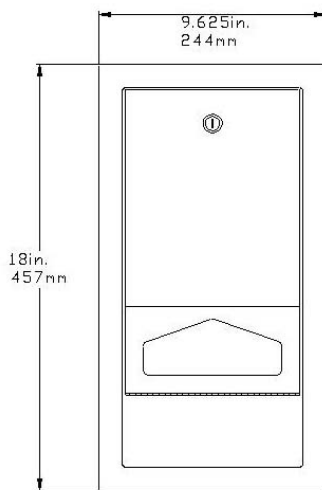

ADA Compliance
(when properly installed)
4.4.1 Max. Protruding Objects
4.2.5 Forward Reach
4.2.6 Parallel Approach
4.27.4 Operation

MATERIALS:

Type 304 brushed stainless steel.

OPERATION:

This unit can be used with the Koala Bear Kare® Countertop Baby Changing Station Recessed Mount (Model KB112-RE), or in restrooms that require a high volume of liners. The dispenser holds approximately 100 sanitary liners.

INSTALLATION:

To insure proper installation and compliance to building codes, it is recommended that a qualified person or carpenter perform the installation of the unit. The Koala Bear Kare® Sanitary Liner Dispenser meets ADA regulations when properly installed. Refer to Federal Register, Volume 56, No. 144 28 CFR Part 36.

Drilling holes and mounting the station:

1. Remove the Dispenser from the shipping container and check for any freight damage. Identify the best location for installing the Dispenser. Hold the unit in place, open it, and make sure that there is adequate operating clearance.
2. Select the wall area where the Dispenser will be installed. Measure from the floor, at the center of the stud, and mark the wall for the appropriate height. Hold the unit in place to verify alignment. Cut a hole in the wall and construct mounting frame. If the wall surface is masonry or tile over wood studs, use caution when cutting the hole for the unit.
3. The unit will be mounted using the proper hardware (not supplied) through the sides of the unit.
4. Place the unit into the recessed area and insert the screws to hold the Dispenser in place. It may be necessary to adjust the squareness of the unit by using a shim on the top right or left side of the unit before tightening securely to the wall.

SPECIFICATION:

Sanitary Liner Dispenser shall be durable type 304 brushed stainless steel. Unit shall have a 100-sanitary liner capacity. Unit shall comply with ADA regulations when properly installed. Unit shall be backed by manufacturers 5-year limited warranty on materials and workmanship. Unit shall be manufactured in the U.S.A.

Sanitary Liner Dispenser shall be model KB134-SSLD of Koala Kare Products