

BABY CHANGING STATION

Surface Mounted

- Model 961 – Grey and White Speckled
- Model 9611 – Solid Light Grey



MODEL 961 MODEL 9611

FEATURES:

- Fabricated of molded, high density polyethylene.
- Attractive, neutral colors: grey and white speckled (model 961) or solid light grey (model 9611).
- Full-length, steel hinge pin. Bed supports a static load of up to 300 lbs.
- Concealed gas shock assists opening and closing; eliminates pinch points.
- Graphics in English and Spanish permanently molded-in.
- Integrated dual paper liner dispenser and molded-in purse/diaper bag hooks.
- Safety strap with 100% unbreakable buckle.
- ADA compliant – opens with less than 5 lbs. of force, projects less than 4" from the wall when closed.

INSTALLATION:

Secure to wall through mounting holes located on 16" or 24" centers. Mounting hardware for typical conditions is included. **NOTE:** Sufficient wall backing (provided by others) is required for proper installation.

GUIDE SPECIFICATION:

Surface mounted baby changing station shall be grey and white speckled (961) or solid light grey (9611) colored molded, high density polyethylene. Hinge shall have full-length steel hinge pin and concealed gas shock. Unit shall include dual integrated paper liner dispensers, molded-in graphics, intergral bag hook, and safety strap with unbreakable buckle. Unit shall be operable with less than 5 lbs. of force and shall withstand a static load of 300 lbs.

Overall dimensions: 35-1/2" W x 24-3/4" H x 3-15/16" D

Surface Mounted baby changing station shall be Bradley Model 961 or 9611.

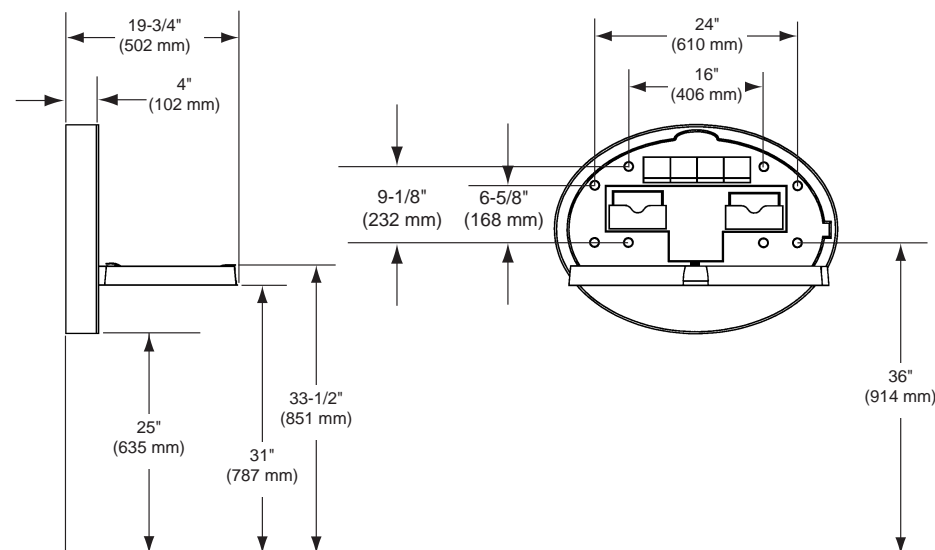

Orders composed of products indicated as *Bradex*™ will be available to ship in one week after receipt of order at the factory. There is no pricing penalty for this service from Bradley.

