

- Recessed
- Contemporary Series — Satin Finish
- ADA Compliant

### Product Materials

**CABINET:** stainless steel.

**FACEPLATE:** 18 gauge stainless steel. Faceplate and soap vessel form one integral piece.

**SOAP VESSEL LINER:** molded high impact polystyrene.

**SOAP VALVE:** chrome-plated brass with ABS mechanism. Internal Buna-N check valves prevent leakage. Requires less than 5 lbs. of force to dispense soap.

### Capacity

32 oz. liquid soap.

### Operation

Soap dispenser slides open for filling and cleaning. Push-in valve dispenses measured amounts of vegetable or coconut oil liquid soaps, synthetic detergents, and antiseptic solutions with less than 5 lbs. of force. Sight gauge indicates refill time. Door secured with tumbler lock.

- Bradley liquid soap valves operate best with any vegetable oil or coconut oil hand soap having a 10–15% soap concentration.

### Installation

Verify all rough-in dimensions prior to installation. Requires rough wall opening 8-1/2"W x 4-1/2"H x 4"D. Secure to framing with mounting screws (included) at holes provided. Shim at screw points as required.

### Guide Specification

Recessed liquid soap dispenser shall be fabricated of stainless steel with exposed surfaces in satin finish. Faceplate of 18 gauge stainless steel and secured by tumbler lock. Capacity: 32 oz. liquid soap.

**Overall dimensions: 10-1/4"W x 6-1/4"H x 4"D.**

### ADA Compliant

- Consult local and national accessibility codes for proper installation guidelines.
- Conformity and compliance to local and national codes is the responsibility of the installer.

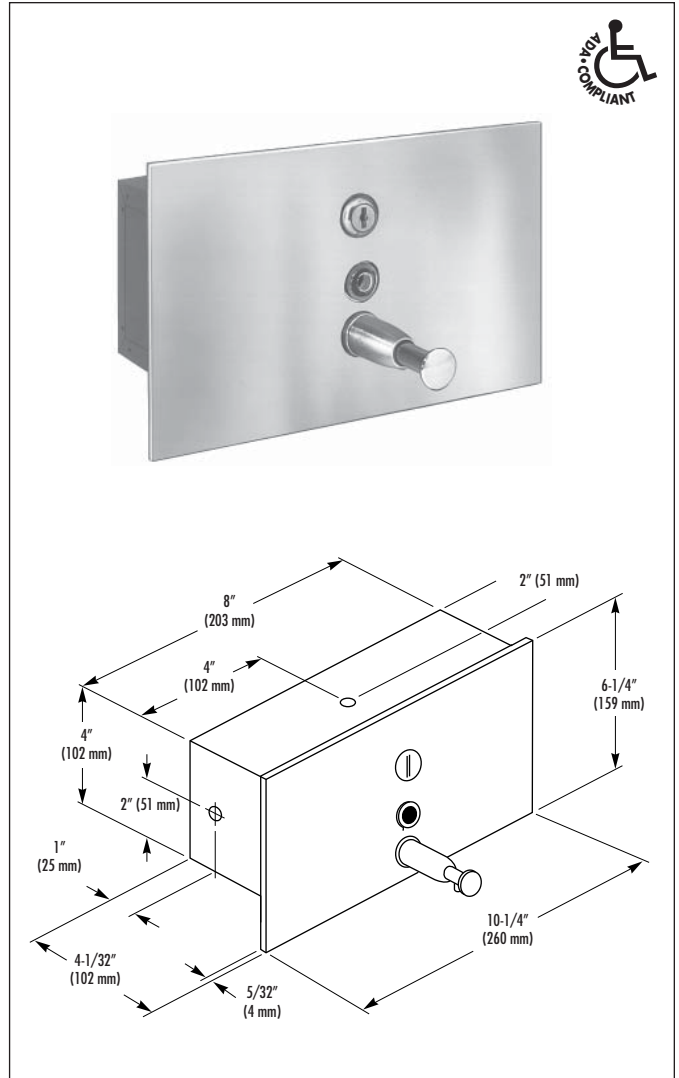

Washroom Accessories  
Document No. 8650

Distributed by  
[www.Ameraproducts.com](http://www.Ameraproducts.com)

Phone: (800) 608-6568

Fax: (409) 840-5545

[info@ameraproducts.com](mailto:info@ameraproducts.com)