

- Standard Series — Satin Finish
- Recessed
- ADA Compliant

Product Materials

FLANGE: 22 gauge stainless steel with exposed surfaces in architectural satin finish. One-piece seamless construction, 1" wide with beveled edges.

CABINET: heavy gauge stainless steel.

SOAP VESSEL: 22 gauge stainless steel with exposed surfaces in architectural satin finish. Tumbler lock keyed like other Bradley units.

SOAP VESSEL LINER: plastic.

SOAP VALVE: chrome-plated brass with ABS mechanism. Internal Buna-N check valves prevent leakage. Requires less than 5 lbs. of force to dispense soap.

Capacity

32 oz. liquid soap.

Operation

Soap dispenser slides open for filling and cleaning. Sight gauge indicates refill time. Valve dispenses measured amount of liquid soap. Requires less than 5 lbs. of force to dispense soap.

- Bradley liquid soap valves operate best with any vegetable oil or coconut oil hand soap having a 10–15% soap concentration.

Installation

Verify all rough-in dimensions prior to installation. Requires rough wall opening 8-1/2"W x 4-1/2"H x 4"D. Secure to framing with mounting screws (included) at holes provided. Shim at screw points as required.

Guide Specification

Recessed liquid soap dispenser shall be fabricated of 22 gauge stainless steel with exposed surfaces in satin finish. Requires less than 5 lbs. force to dispense soap. Capacity: 32 oz. liquid soap.

Overall dimensions: 10"W x 6"H x 4"D.

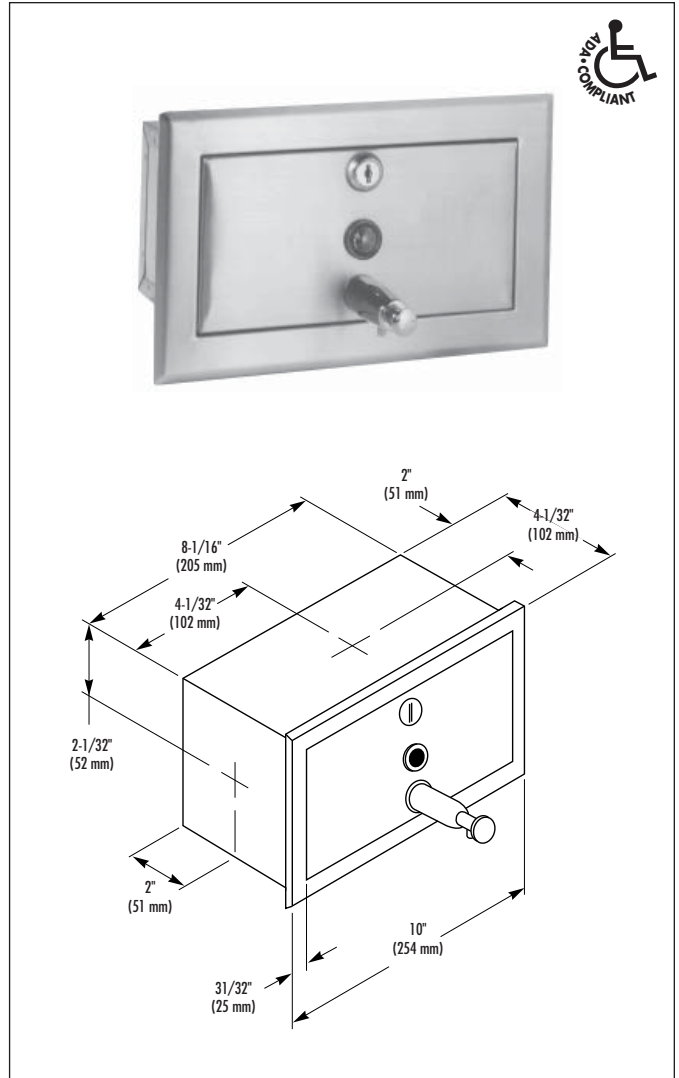

ADA Compliant

- Consult local and national accessibility codes for proper installation guidelines.
- Conformity and compliance to local and national codes is the responsibility of the installer.

Washroom Accessories
Document No. 8645

Distributed by
www.Ameraproducts.com
Phone: (800) 608-6568
Fax: (409) 840-5545
info@ameraproducts.com