

# SOAP DISPENSER

- Tank Type — Horizontal
- Surface Mounted

**Bradex™**

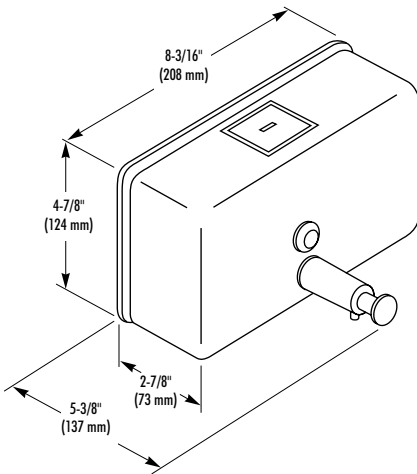

### CONSTRUCTION:

- **BODY** fabricated of type 304 (18-8), 20 gauge stainless steel with exposed surfaces in architectural satin finish.
- **BACK** fabricated of type 304 (18-8), 20 gauge stainless steel. Heliarc welded to the body.
- **WALL PLATE** of heavy gauge stainless steel.
- **SOAP VALVE** has chrome plated brass housing with ABS plastic mechanism.

### CAPACITY:

40 oz. liquid soap.

### OPERATION:

Push-in valve dispenses measured amount of vegetable or coconut oil liquid soaps, synthetic detergents, and antiseptic solutions. Locked filler top opens with special key provided.

### INSTALLATION:

Secure separate mounting bracket to wall. Slide dispenser into place and secure locking screw through filler hole.

### OPTIONAL FEATURES:

Feature	Suffix
<input type="checkbox"/> Lather soap valve in lieu of liquid	-13

### GUIDE SPECIFICATION:

Surface mounted liquid soap dispenser shall be fabricated of 20 gauge satin finish stainless steel. Dispenser shall have completely concealed mounting, vandal-resistant filler hole cover and sight gauge. Push-in corrosion-resistant liquid soap valve. Capacity: 40 oz. liquid soap.

Overall dimensions: 8-3/16"W x 4-7/8"H x 2-7/8"D.

**Surface Mounted Liquid Soap Dispenser shall be Bradley Model 6542.**