

# SOAP DISPENSER

- Recess Mounted

**Bradex™**

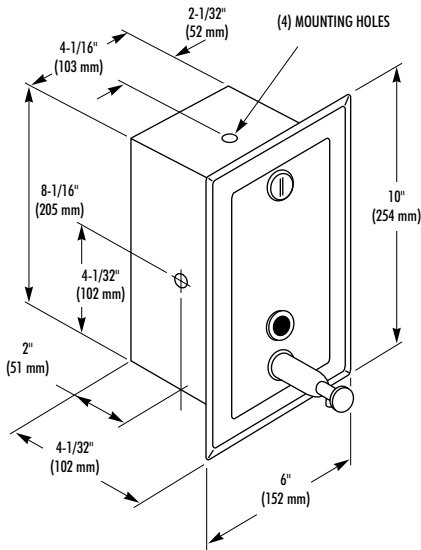

## MODEL 644

### CONSTRUCTION:

- **FLANGE** fabricated of type 304 (18-8), 22 gauge stainless steel with exposed surfaces in architectural satin finish. One piece seamless construction, 1" wide with beveled edges.
- **CABINET** fabricated of type 304 (18-8), heavy gauge stainless steel.
- **SOAP VESSEL** fabricated of type 304 (18-8), 22 gauge stainless steel with exposed surfaces in architectural satin finish. Tumbler lock keyed like other Bradley units.
- **SOAP VALVE** of chrome plated brass with ABS mechanism. Internal Buna-N check valves prevent leakage.

### CAPACITY:

40 oz. liquid soap.

### OPERATION:

Soap dispenser slides open for filling and cleaning. Sight gauge indicates refill time. Valve dispenses measured amount of liquid soap.

### INSTALLATION:

Requires rough wall opening 4-1/2"W x 8-1/2"H x 4"D. Secure to framing with mounting screws (included) at holes provided. Shim at screw points as required.

### GUIDE SPECIFICATION:

Recessed liquid soap dispenser shall be fabricated of type 304 (18-8), heavy gauge stainless steel with exposed surfaces in satin finish. Capacity: 40 oz. liquid soap.

Overall dimensions: 6"W x 10"H x 4"D.

**Recessed Soap Dispenser shall be Bradley Model 644.**

Document No. 8660

This information is subject to change without formal notice.  
MD 3239-1198