

MODEL 170

MULTI-PURPOSE UNIT

- Model 170 – Recessed
- Model 170-11 – Surface Mounted (projects 4")

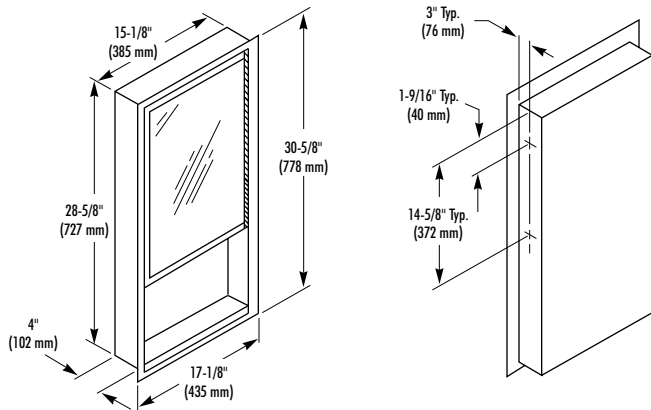

CONSTRUCTION:

- **FLANGE** fabricated of type 304 (18-8), 22 gauge stainless steel with exposed surfaces in architectural satin finish. One piece seamless construction, 1" wide with 1/4" return.
- **CABINET** fabricated of type 304 (18-8), 26 gauge stainless steel.
- **DOOR** fabricated of type 304 (18-8), 22 gauge stainless steel, with heavy duty full length piano hinge and tumbler lock.
- **MIRROR** of first quality 1/4" float glass triple-silvered, electro-copper plated with baked enamel backing, guaranteed for 15 years against silver spoilage. Protected by shock absorbing filler.
- **INTERIOR SHELVES** fabricated of type 304 (18-8), 22 gauge stainless steel. Three shelves – two adjustable, one fixed. Each shelf area is 60 sq. in.
- **EXTERIOR SHELF** fabricated of type 304 (18-8), 22 gauge stainless steel with an area of 60 sq. in.
- **LOCK** on door keyed like other Bradley units.

OPERATION:

Mirrored door conceals interior shelves.

INSTALLATION:

Recessed unit requires rough wall opening 15-5/8"W x 29-1/8"H x 4"D. Top of wall opening 6'-1" above finished floor. Secure to framing with mounting screws (included) at holes provided. Shim at screw points as required.

OPTIONAL FEATURES:

Feature	Suffix
<input type="checkbox"/> Tempered glass in lieu of float glass	-22
<input type="checkbox"/> #8 Stainless steel mirror in lieu of glass	-23
<input type="checkbox"/> Adjustable tilt mirror	-25
<input type="checkbox"/> Fixed tilt mirror	-26

NOTE: An inherent characteristic of a manufacturing process is distortion which may vary from mirror to mirror.

GUIDE SPECIFICATION:

Recessed multi-purpose unit, consisting of mirror and storage cabinet with three shelves, shall be fabricated of type 304 (18-8), stainless steel with exposed surfaces in satin finish. Mirrored door with full length piano hinge and tumbler lock. Interior of storage cabinet to have three shelves – two adjustable and one fixed.

Overall dimensions: 17-1/8"W x 30-5/8"H x 4"D.

Recessed Multi-Purpose Unit shall be Bradley Model 170.