

RD0025

# Two-Roll Standard Tissue Dispenser



## FEATURES



- Double latch lock works with standard metal key
- Heavy gauge steel back constructed for maximum strength
- Space saving design
- Easy access to reserve roll
- Enclosed second roll for maximum hygiene
- 2-roll capacity avoids supply run out
- Permanent key knob available

## AVAILABLE COLORS

Dark Translucent Cover  
with a Beige Back



White Translucent Cover  
with a Beige Back



## SPECIFICATIONS

Model #	RD0025-01 (Dark Translucent) RD0025-03 (White Translucent)		
Dimensions	6.02" W x 13.13" H x 6" D		
Weight	2.10 lbs	Case Pack	6 per case - 2.28' <sup>3</sup>
Capacity	2 - 4½" W x 5¼" D Rolls (1½" Core)	Key Type	1

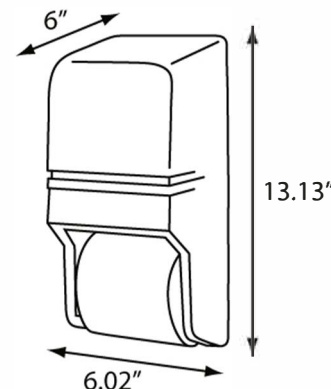

Palmer Fixture  
P.O. Box 10887  
Green Bay, WI 54307

