



Distributed by
 www.Ameraproducts.com
 Phone: (800) 608-6568
 Fax: (409) 840-5545
 info@ameraproducts.com

VALVE BOXES

Model KRVB

(Recessed)

DATE



KARP ASSOCIATES, INC.
 260 Spagnoli Road Melville, NY 11747

SPECIFICATIONS

GENERAL SCOPE:

Access doors shall be Karp Type KRVB (Recessed) as manufactured by Karp Associates, Inc., Melville, N.Y. Sizes shall be as indicated on the drawings.

CONSTRUCTION:

1. Box shall be 16 gage steel and door shall 14 gage steel.
2. Hinge shall be concealed, continuous piano hinge.
3. Locks shall be flush and screwdriver operated with cam and studs, or shall be key operated cylinder lock with automatic dust shutter.
4. Holes 1/4" diameter shall be provided for anchoring to framing.
5. Finish shall be prime coat of rust inhibitive electrostatic powder, baked white enamel. Available in stainless steel No.4 Satin Polish Finish.

PROJECT DATA						
Project Name:						
Architect:						
Contractor:						
Agent/Customer Name:						
Tagging Instructions:						
Special Instructions:						

PROJECT SCHEDULE						
Qty.	H	W	D	No. of Latches	Finish	Remarks

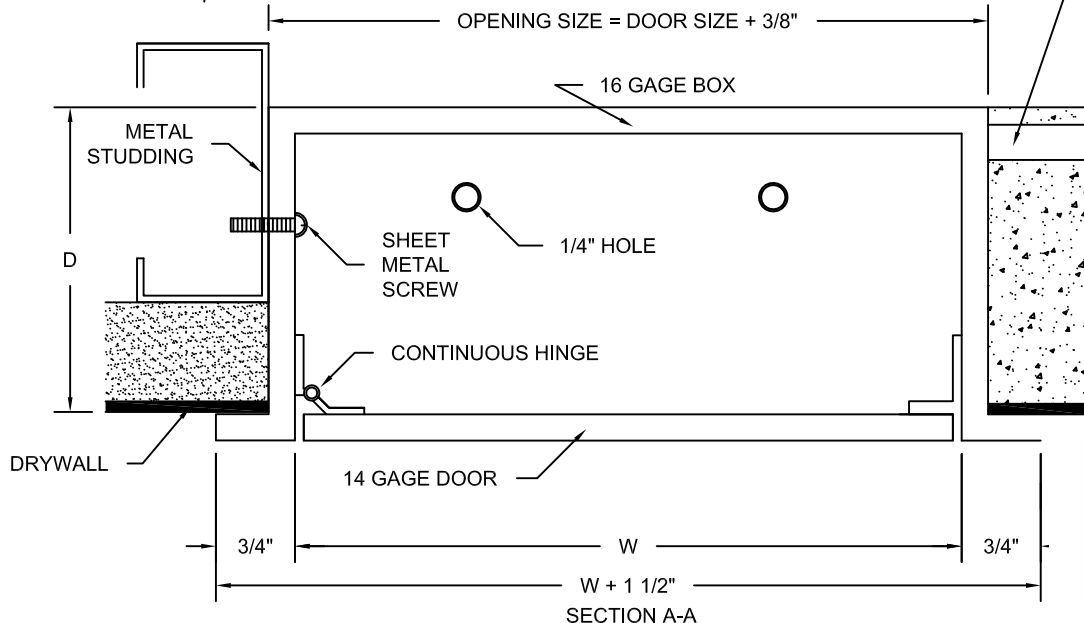
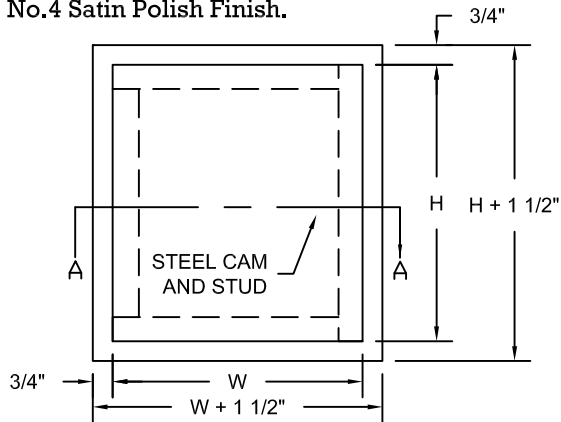

OPTIONAL
 ANCHOR
 STRAPS



Made with Union Labor