

Wall Installation Instructions for B-Label, Fire-Rated KRP-150FR, KRP-250FR, KRP-350FR & KRP-450FR

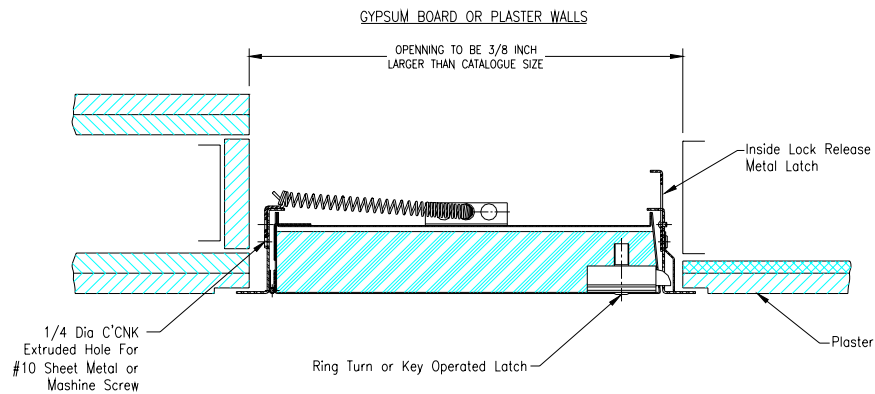

1. With metal or wood studding, install a framed opening at specified location of door. Opening dimensions should be 3/8" larger than catalog size of door; i.e., for 12" x 12" door, opening should be 12 3/8" x 12 3/8".
2. Frame above and below access door.
3. On doors larger than 16" x 16", install a double stud on both sides in the same manner as at passage doors.
4. Place door in position in opening and mark location of attachments on studding, using holes in latch and hinge sides of door frame as marking guides.
5. Remove door, and drill 4-5/32" holes through studding at points marked for attachment holes for doors 32" x 32" and smaller; six for larger size doors.
6. Place door in position, leaving masonry anchor straps flat against door frame, and attach with #10 sheet metal or machine screws.
7. Check door panel for freedom of movement. If it binds, shim to remove any frame racking at stud attachments.
8. When mounting access panels with galvanized beaded frame (instead of 1" steel trim), use drywall cement to cover and conceal the flange at the same time wall board joints and corners are being cemented.

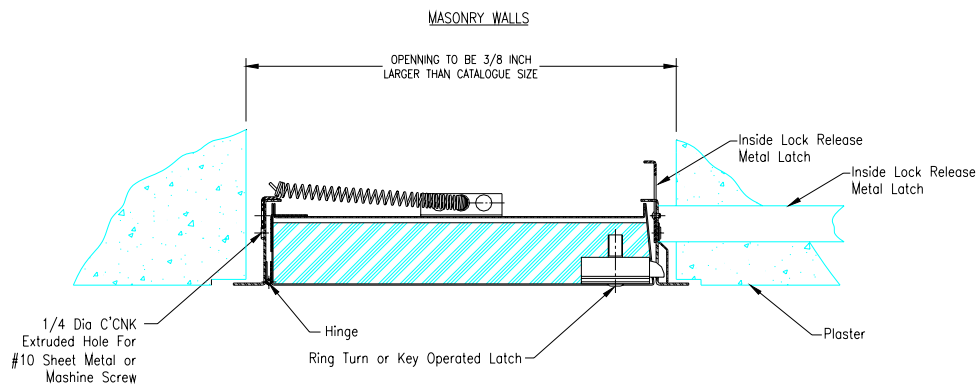

1. Opening should be planned with dimensions 3/8" larger than catalog size of door; i.e., for a 12" x 12" door, opening should be 12 3/8" x 12 3/8". (A notched-out area of 2 1/4"L x 7/8"W x 1/2"D is required for the lock bolt cover.)
2. If wall is under construction at door installation time, use masonry anchors (unfolded from frame) for attachment.
3. If wall is already in place, position door in opening provided for it and mark location of attachments on wall, using holes in latch and hinge sides of door frame as marking guides.
4. Remove door, and install 4 expansion shields in wall at points marked for doors 32" x 32" or smaller; six for larger doors.
5. Place door in position (leaving masonry anchors flat against frame) and attach with #10-32 x 1" long flat-head steel machine screws or equivalent.
6. Check door panel for freedom of movement. If it binds, shim to remove any frame racking at masonry attachments.
7. Use mortar between door frame and block wall to provide a complete closure around door frame.