

# B-NT SERIES

NON-RATED FLUSH ACCESS PANEL FOR ALL SURFACES

Distributed by  
**www.Ameraproducts.com**  
 Phone: (800) 608-6568  
 Fax: (409) 840-5545  
 info@ameraproducts.com

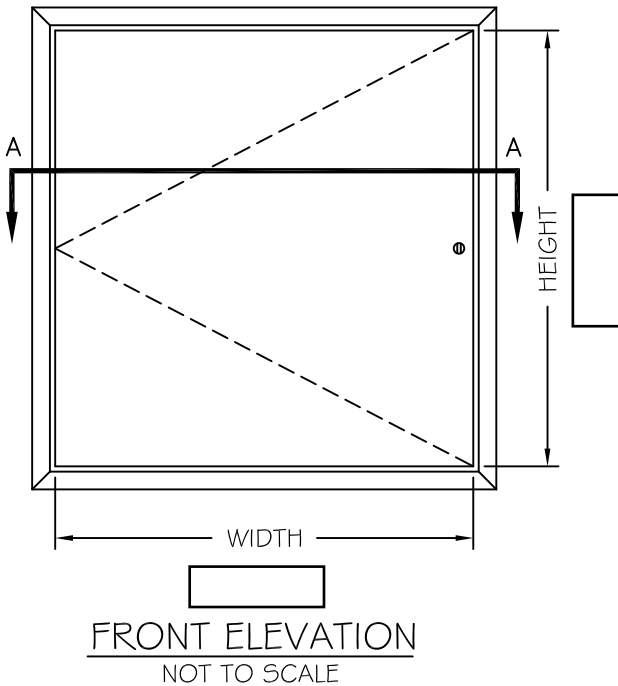

## SPECIFICATIONS

- 16 GAUGE (1.520mm) COLD ROLLED STEEL FRAME
- 14 GAUGE (1.900mm) COLD ROLLED STEEL DOOR
- GRAY BAKED ON POWDER COAT FINISH
- SPRING PIN HINGE (CONCEALED)
- FRAMES ARE PROVIDED WITH .25" MOUNTING HOLES
- FLUSH SCREWDRIVER OPERATED CAM LATCH (ADDITIONAL CAMS PROVIDED ON PANELS 18" X 18" AND GREATER IN SIZE)

## OPTIONS

- KEY OPERATED CAM LOCK
- PINNED ALLEN HEAD SECURITY CAM LATCHES
- PREPARATION FOR 1.125" MORTISE CYLINDER (CYLINDER PROVIDED BY OTHERS OR BY FACTORY)
- FLUSH CONTINUOUS HINGE (STANDARD ON PANELS GREATER THAN 24" x 36" IN SIZE & ALL STAINLESS STEEL PANELS)
- CONCEALED PIANO HINGE
- STAINLESS STEEL (TYPE 304) WITH A #4 SATIN POLISH FINISH
- GALVANIZED BONDZERIZED STEEL
- MASONRY ANCHORS ATTACHED
- GASKET, 3 SIDES (CLOSED CELL)

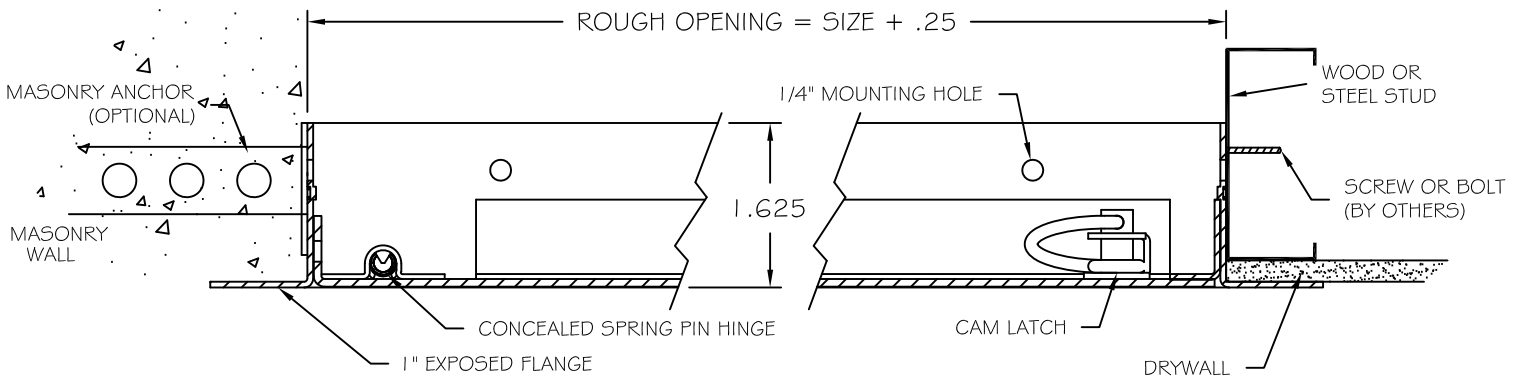

A CUT-THRU SECTION  
 A NOT TO SCALE



PROJECT:

CONTRACTOR:

ARCHITECT:

INITIALS:      QTY:      DATE:      PART NUMBER:

# B-NT SERIES

## Standard Features:

- Door: 14 gauge (1.90mm thick) cold rolled steel  
 Frame: 16 gauge (1.52mm thick) cold rolled steel with 1" Flange  
 Hinge: Concealed spring pin hinge  
 Optional: Continuous piano hinge  
 Latch: Screwdriver operated cam latch(es)  
 Optional: Key operated cam lock, pinned allen head security cam latch(es), mortise cylinder preparation (cylinder provided by factory or by others)  
 Finish: Gray baked on powder coat  
 Optional: galvanized bonderized or stainless steel with #4 satin polish finish

## Specifications:

Frame shall be 16 gauge cold rolled steel with 1" flange. Door shall be fabricated from 14 gauge cold rolled steel. Hinge shall be concealed spring pin hinge that allows door to be removed (non-removeable flush continuous piano type on all stainless steel panels and those exceeding 24" wide and/or 36" high). Latch(es) shall be screwdriver operated cam type (optional: key operated cam lock, pinned allen head security cam latch, or preparation to receive 1 1/8" mortise cylinder - cylinder provided by factory or others). Finish shall be gray baked on powder coat (optional: galvanized bonderized steel or stainless steel with #4 satin polish finish).

Installation shall be in accordance with manufacturers instructions. Manufacturer shall guarantee against defects in material and workmanship for a period of one year.

## Standard Sizes:

Std Sizes (in)	Std Sizes (mm)	Weight/Latches	Std Sizes (in)	Std Sizes (mm)	Weight/Latches
06x06	152x152	3/1	20x30	508x762	19/5
08x08	203x203	4/1	22x22	559x559	19/4
10x10	254x254	5/1	22x30	559x762	22/5
12x12	305x305	7/1	24x24	610x610	20/4
12x18	305x457	10/1	24x30	610x762	24/5
12x24	305x610	12/1	24x36	610x914	28/5
14x14	356x356	8/1	24x48	610x1219	33/6
16x16	406x406	11/1	30x30	762x762	26/5
16x20	406x508	12/2	32x32	813x813	29/5
18x18	457x457	12/2	36x36	914x914	36/5
18x24	457x610	18/2	36x48	914x1219	52/6

\* Denotes non-removable continuous piano hinge - standard on all stainless steel panels.  
 All units are hinged on the second dimension (height). Rough opening is door size plus 1/4".

