

Stainless Steel Baby Changing Station Semi-Recessed Mount

KB111-SSRE

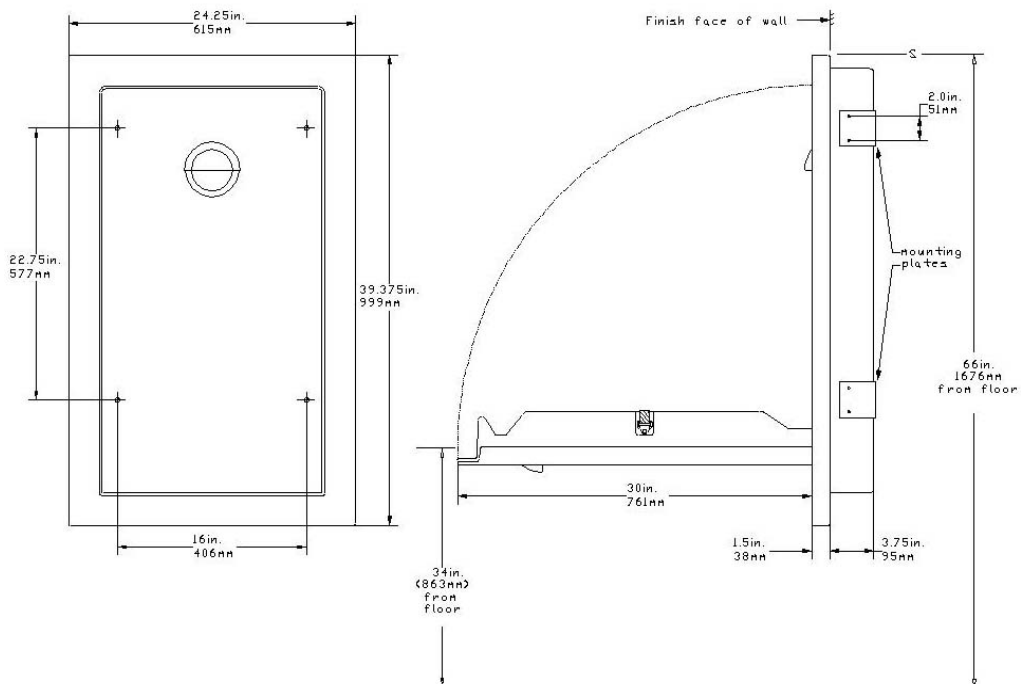

The illustrations and descriptions herein are applicable to production as of the date of this technical data sheet.
The manufacturer reserves the right to make changes and improvements in designs and dimensions without notice.



ADA Compliance
(when properly installed)
4.4.1 Max. Protruding Objects
4.2.5 Forward Reach
4.2.6 Parallel Approach
4.27.4 Operation

MATERIALS:

FDA approved blow molded high-density polyethylene clad in 304 brushed stainless steel. Reinforced full-length steel-on-steel hinge mechanism, with 11-gauge steel mounting plates and mounting hardware included. Contoured changing surface area is 420 sq in (2730 sq mm) and comes complete with nylon safety straps and bag hooks.

OPERATION:

Concealed pneumatic cylinder and hinge structure provides controlled, slow opening and closing of bed. Stainless steel is easy to clean and resists odors and bacterial growth. Complies with ASTM static load performance requirements when properly installed. Rated to support a static load of 300 pounds (136 kilos); tested to 400 pounds (182 kilos). Built-in liner dispenser holds approximately 25 KB150-99 sanitary liners.

Warning: To insure that the unit supports the intended loads, baby changing stations must be properly installed according to the manufacturer's instructions.

INSTALLATION:

To insure proper installation and compliance to building codes, it is recommended that a qualified person or carpenter perform the installation of the unit. Koala Bear Kare® Baby Changing Stations have been tested to hold a static load of up to 400 pounds. To do this, the unit must be properly installed onto a permanent wall that is capable of supporting that much weight and can accommodate the supplied

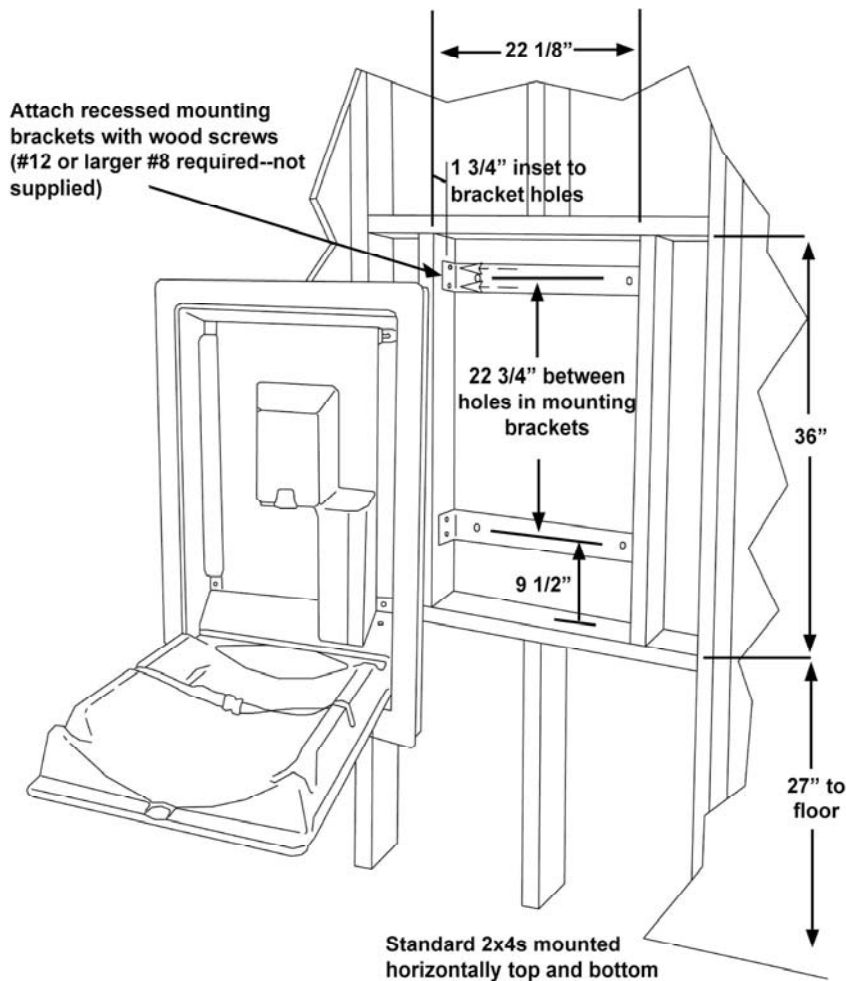

Drilling holes and mounting the station:

1. Remove the station from the shipping container and check for any freight damage. Identify the best location for installing the baby changing station. Hold the unit in place, open the bed, and make sure that there is adequate operating clearance.
2. Select the wall area where the Baby Changing Station will be installed. Measure from the floor, at the center of the stud, and mark the wall for the appropriate height. Hold the unit in place to verify alignment. Cut a hole in the wall and construct mounting frame as shown in the illustration. If the wall surface is masonry or tile over wood studs, use caution when cutting the hole for the unit.
3. The unit comes with two mounting brackets that need to be secured to the mounting frame as shown in the illustration.

The illustrations and descriptions herein are applicable to production as of the date of this technical data sheet. The manufacturer reserves the right to make changes and improvements in designs and dimensions without notice.

4. Place the unit into the recessed area and insert the capped nuts and washers to hold the Baby Changing Station in place. It may be necessary to adjust the squareness of the door by using a shim on the top right or left side of the unit before tightening securely to the wall.

installation hardware. The Koala Bear Kare® Baby Changing Station meets ADA regulations when properly installed. Refer to Federal Register, Volume 56, No. 144 28 CFR Part 36.

SPECIFICATION:

Baby changing station body shall be durable, high-impact polyethylene clad in 304 brushed stainless steel. Design of unit shall be semi-recess-mounted. Unit shall be equipped with a pneumatic cylinder for controlled opening and closing of bed. Bed shall be secured to back plate with a concealed, full-length steel-on-steel hinge. No hinge structure shall be exposed on interior or exterior surfaces. Unit shall have 11-gauge steel mounting plates with mounting hardware included. Unit shall conform to ANSI S117.1, ASTM PS 125 (federal regulation compliance, load support, pinch points, child restraint), ANSI Z535.4, R-0367 German TUV or local code if more stringent installation requirements are applicable for handicapped accessibility. Unit shall comply with ADA regulations when properly installed. Bed shall have smooth concave changing area with a nylon safety strap and two hooks for bags or purses. Unit shall have a built-in Liner Dispenser for use with 3-ply chemical free biodegradable sanitary liners, universal instruction graphics and safety messages in 6 languages. Manufacturer's service and parts manual shall be provided to the building owner/manager upon completion of project. Unit shall be backed by manufacturers 5-year limited warranty on materials and workmanship, or 5-year replacement warranty against vandalism. Unit shall be manufactured in the U.S.A.