

Stainless Steel Baby Changing Station Surface Mount

KB110-SSWM

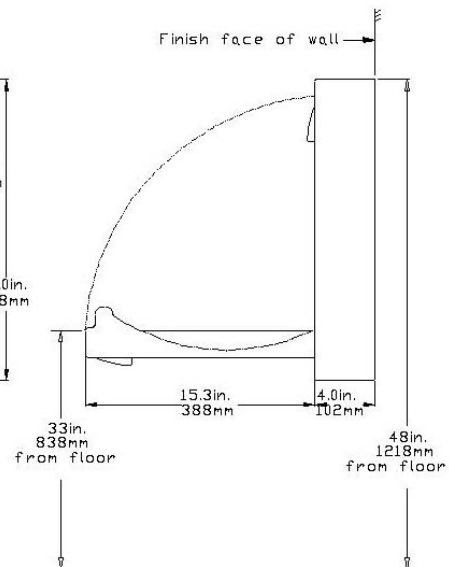
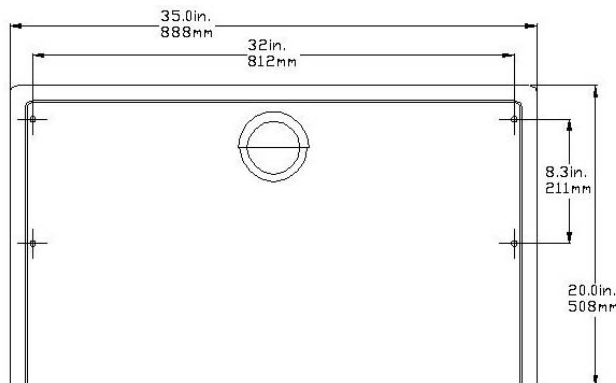

ADA Compliance
(when properly installed)
4.4.1 Max. Protruding Objects
4.2.5 Forward Reach
4.2.6 Parallel Approach
4.27.4 Operation

MATERIALS:

FDA approved blow molded high-density polyethylene clad in 304 brushed stainless steel. Reinforced full-length steel-on-steel hinge mechanism, with 11-gauge steel mounting plates and mounting hardware included. Contoured changing surface area is 442 sq in (2873 sq mm) and comes complete with nylon safety straps and bag hooks.

OPERATION:

Concealed pneumatic cylinder and hinge structure provides controlled, slow opening and closing of bed. High-density polyethylene is easy to clean and resists odors and bacterial growth. Complies with ASTM static load performance requirements when properly installed. Rated to support a static load of 300 pounds (136 kilos); tested to 400 pounds (182 kilos). Built-in liner dispenser holds approximately 25 KB150-99 sanitary liners.

Warning: *To insure that the unit supports the intended loads, baby changing stations must be properly installed according to the manufacturer's instructions.*

INSTALLATION:

To insure proper installation and compliance to building codes, it is recommended that a qualified person or carpenter perform the installation of the unit. Koala Bear Kare® Baby Changing Stations have been tested to hold a static load of up to 400 pounds. To do this, the unit must be properly installed onto a permanent wall that is capable of supporting that much weight and can accommodate the supplied installation hardware. The Koala Bear Kare® Baby Changing Station meets ADA regulations when properly installed. Refer to Federal Register, Volume 56, No. 144 28 CFR Part 36.

Drilling holes and mounting the station:

1. Remove the station from the shipping container and check for any freight damage. Identify the best location for installing the baby changing station. Hold the unit in place, open the bed, and make sure that there is adequate operating clearance.
2. Based upon the type of wall on which the unit will be mounted, determine the best method of mounting. Not all of included hardware may be required for proper installation.
3. The horizontal unit has four mounting holes provided in the back wall of the unit, which are positioned on a 32" stud center. If possible, locate the wood or metal wall studs for fastening the changing station in the desired location. If the walls do not have studs on the center as outlined, make sure at least one side of the unit is installed into the stud. Use toggles (supplied) for holes on the other side.
4. Find the stud where you will be attaching the left side of the changing station to the wall. Measure 48" up from the floor (44" ADA), at the center of the stud, and mark the wall. Line up the top left mounting hole with this mark, then use a measuring tape and level to mark the remaining three mounting holes. This will locate the bottom of the station 30-1/2" from the floor (26-1/2" ADA).

Using Wood Screws:

If the wall has wood studs on 16" or 32" centers, drill 1/8" pilot holes at the marks and use the four 1/4" x 3" panhead tapping screws with supplied washers. If the wall is masonry or tile over wood studs, use a 7/32" masonry drill until you hit the stud, then proceed to drill 1/8" pilot holes into the studs and use the four 1/4" x 3" panhead tapping screws with supplied washers.

Using Toggle Fasteners:

If the wall has wood studs that are not on 16" or 32" centers, has metal studs, or an underlying surface of concrete block, drill with a 1/2" masonry bit. A minimum of 2-1/2" of inside wall space is required for toggles to turn. Insert supplied toggles and tighten, locate station over toggles, then use supplied 1/4" x 3" Phillips Panhead machine screws with supplied washers.

SPECIFICATION:

Baby changing station body shall be durable, high-impact polyethylene clad in 304 brushed stainless steel. Design of unit shall be surface-mounted. Unit shall be equipped with a pneumatic cylinder for controlled opening and closing of bed. Bed shall be secured to back plate with a concealed, full-length steel-on-steel hinge. No hinge structure shall be exposed on interior or exterior surfaces. Unit shall have 11-gauge steel mounting plates with mounting hardware included. Unit shall conform to ANSI S117.1, ASTM PS 125 (federal regulation compliance, load support, pinch points, child restraint), ANSI Z535.4, R-0367 German TUV or local code if more stringent installation requirements are applicable for handicapped accessibility. Unit shall comply with ADA regulations when properly installed. Bed shall have smooth concave changing area with a nylon safety strap and two hooks for bags or purses. Unit shall have a built-in Liner Dispenser for use with 3-ply chemical free biodegradable sanitary liners, universal instruction graphics and safety messages in 6 languages. Manufacturer's service and parts manual shall be provided to the building owner/manager upon completion of project. Unit shall be backed by manufacturers 5-year limited warranty on materials and workmanship, or 5-year replacement warranty against vandalism. Unit shall be manufactured in the U.S.A.