



Literature 200 series documents
C.O.I.S. TD 400 series documents
CSI 3 part 600 series documents

C.O.I.S. Technical Data Sheet

CAD
Operation
Installation
Specification

Document #412
Issued 08-2007

MODEL
103BQS

Stock item as of Sept. 07

Document Index

Pg. 1 Coversheet

Pg. 2 CAD Drawings

Pg. 3-4 Install/CMW (Cleaning, Maintenance, Warranty)



INSTALL FOR ADA COMPLIANCE (CAL UBC Title 24)

SIDE VIEW OPEN

- Max Protruding Objects

- o 4.4.1
- o Unit does not exceed 4ö. Ok to mount to partition wall only.
Do not mount to door.

- Forward Reach

- o 4.2.5
- o Mount bottom of unit no higher than 34ö AFF.

- Side Reach

- o 4.2.6
- o Mount bottom of unit no higher than 40ö AFF.

- Operations

- o 4.27.4
- o Compliant

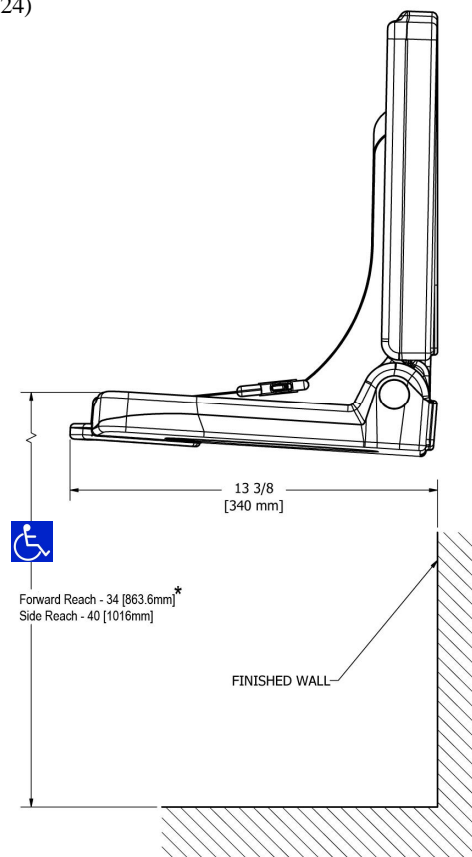

Also available as PDF



Stock item as of Sept. 07

FRONT VIEW

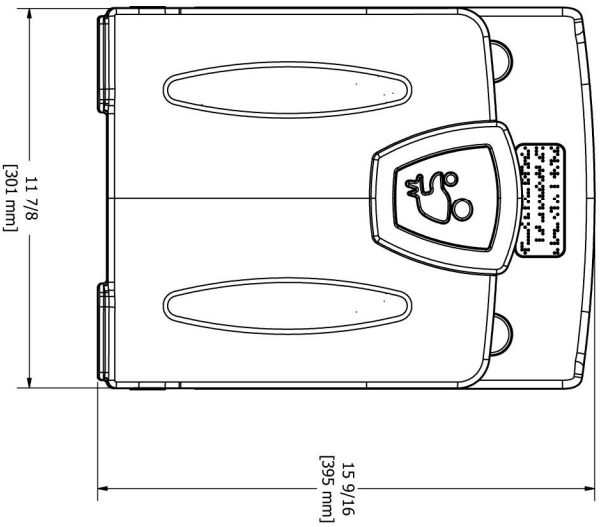

SIDE VIEW CLOSED

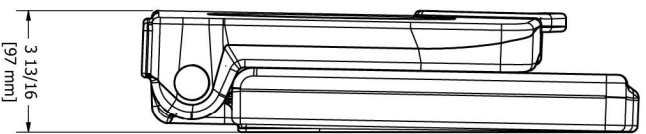

SIDE VIEW OPEN

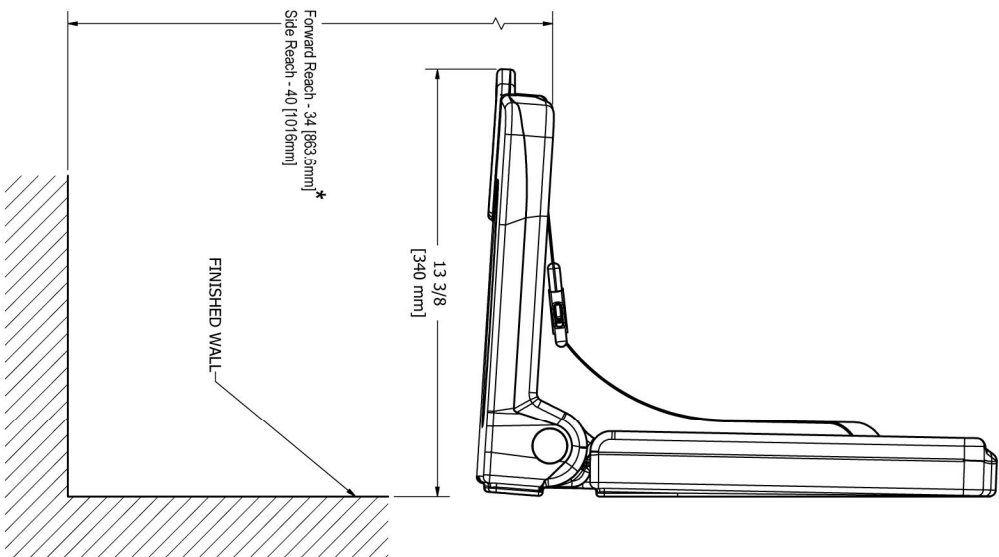

BACK VIEW

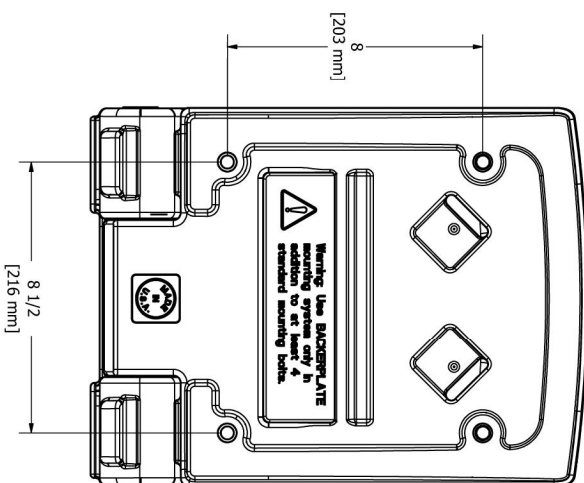

*For ADA Compliance of either forward or side reach (see cover sheet for further details)

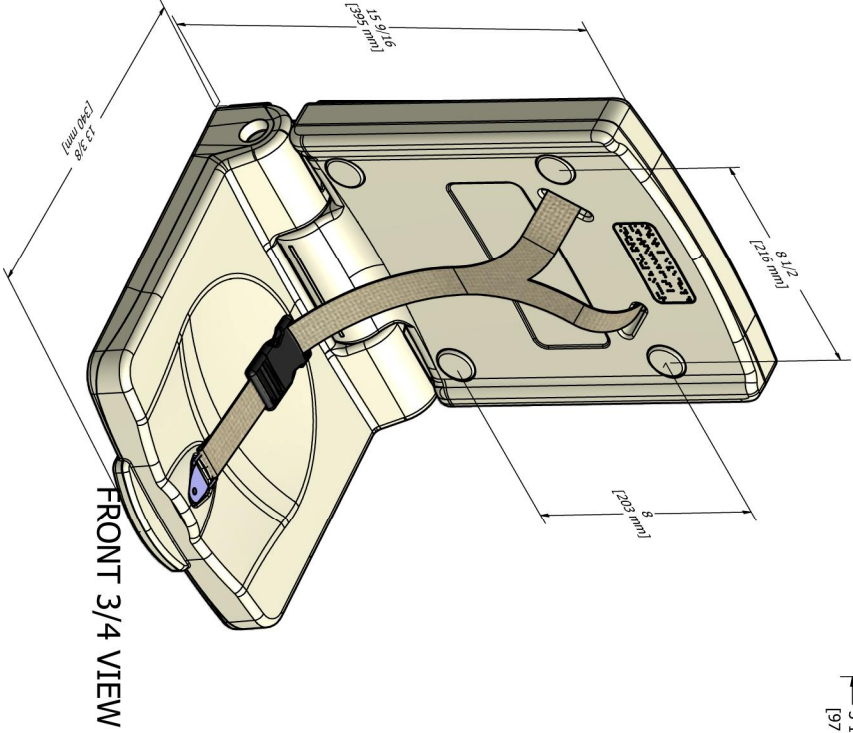

103BQS

CMW:

- Cleaning-
Brocar polyethylene and stainless diaper changing stations should be cleaned with a soft cloth or sponge and a non-abrasive cleaner. Warm water or an organic solvent can be used. The preferred solvent is one that does not contain chlorine, such as acetone, methyl alcohol or mineral spirits. There are many compounded or blended organic cleaners commercially available to optimize attributes of both cleanliness and safety.

- Inspection-
Safety strap: Inspect the buckle and strap for proper functioning as part of the facility's washroom cleaning and maintenance schedule.

Safety label: If the safety label is missing, restrict the unit from use by taping it closed as well as labeling the unit "inoperable" or removing the unit from the wall until a new label is installed.

Hinges, mounting hardware: Ensure that the hinges and mounting bolts are not loose by pulling the unit toward you and from side to side. If any play exists greater than 1/4" or 2.5mm in any direction, discontinue use of the unit by taping it closed or removing it from the wall, as well as labeling the unit "inoperable." Contact professional maintenance personnel to diagnose and correct problem.

- Instructions For Use
Information for product use is presented in the form of five graphic symbols within labeling adhered to each product. The symbols and color scheme design comply with ANSI Z535.4 Product Safety Signs & Labels, ANSI Z535.3 Criteria for Safety Symbols and ANSI Z535.1 Safety Color Code. As noted above, verification of this label's presence on the unit should be made as part of daily cleaning.

- Warranty and Liability
Product Liability Insurance General Liability: \$1,000,000. Excess liability \$10,000,000.

Warranty

Brocar Products, Incorporated warrants its products against defective material and manufacturing defects (but not improper use) for a period of five years after sale. Brocar Products' liability under this warranty shall be limited to the repair or replacement of the defective product. There shall be no other remedy available, including without limitation, recovery for incidental or consequential damages, injury to person, property, or any other incidental or consequential loss.

The warranty described above shall be IN LIEU OF any other warranty, expressed or implied, including without limitation, any implied warranty of MERCHANTABILITY or fitness for a particular purpose.

Installation on Toilet Partition:

1. Unit should be mounted in a convenient location. If mounting in a changing room, mount so bottom of unit is approx. 24" from the floor. Make sure there is adequate clearance in front of the seat for safe operation.
2. Mark a level line at proper height, use the seat as a template for four mounting holes and drill 3/8" holes through partition at mounting points.
3. From opposite side of partition, insert 4 T-nuts into mounting holes.
4. Insert 4 machine screws with washers through holes in 103BQS seat and through holes in partition.
5. Secure 4 machine screws through spacers and tightly into T-nuts.
6. Operate seat 3 or 4 times to ensure proper function.

Specification:

Polyethylene child wall seat

1. Acceptable product: Brocar Products, Inc.; Model 103BQS
2. Characteristics:
 - a. Type: Molded FDA approved high-density polyethylene (HDPE) body
 - b. Rated for infant and accessories up to 50lbs (22.68kg)
 - c. Child protection strap featuring three point safety harness