

- Tank Type Vertical **Bradex®**
- Surface-Mounted
- ADA Compliant

Product Materials

BODY: 20 gauge stainless steel with exposed surfaces in architectural satin finish.

BACK: 20 gauge stainless steel; heliarc welded to the body.

WALL PLATE: stainless steel.

SOAP VALVE: chrome-plated brass housing with ABS plastic mechanism.

Capacity

40 oz. liquid soap.

Operation

Push-in valve dispenses measured amount of vegetable or coconut oil liquid soaps, synthetic detergents, and antiseptic solutions with less than 5 lbs. of force. Sight gauge indicates refill time. Locked filler top opens with special key provided.

- Bradley liquid soap valves operate best with any vegetable oil or coconut oil hand soap having a 10–15% soap concentration.

Installation

Verify all rough-in dimensions prior to installation. Secure separate mounting bracket to wall. Slide dispenser into place and secure locking screw through filler hole.

Guide Specification

Surface-mounted liquid soap dispenser shall be fabricated of 20 gauge satin finish stainless steel. Dispenser shall have completely concealed mounting, vandal-resistant filler hole cover and sight gauge. Push-in corrosion-resistant liquid soap valve. Capacity: 40 oz. liquid soap. Requires less than 5 lbs. of force to dispense soap.

Overall dimensions: 4-13/16"W x 8-3/16"H x 2-7/8"D.

ADA Compliant

- Consult local and national accessibility codes for proper installation guidelines.
- Conformity and compliance to local and national codes is the responsibility of the installer.

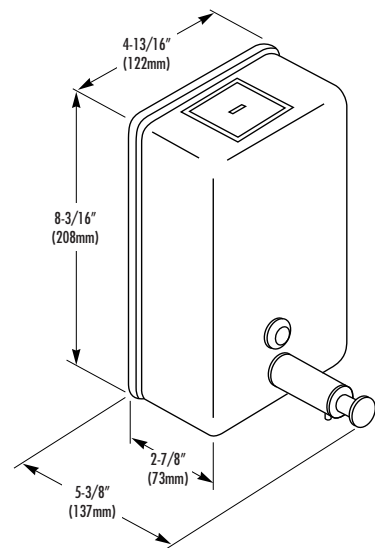

Washroom Accessories
Document No. 8690

Distributed by
www.Ameraproducts.com
Phone: (800) 608-6568
Fax: (409) 840-5545
info@ameraproducts.com