

- Specify Color \_\_\_\_\_ (see color chart in back of catalog)
- Recessed
- Accent Series — Color Laminate
- ADA Compliant

## Product Materials

**CABINET:** stainless steel.

**FACEPLATE:** 5/16" thick solid laminate, made of colored Melamine bonded under high pressure to a phenolic core. All exposed edges are machined smooth to a uniform dark finish. Faceplate and soap vessel form one integral piece. Tumbler lock keyed like other Bradley units.

**SOAP VESSEL:** 22 gauge stainless steel with exposed surfaces in architectural satin finish.

**SOAP VESSEL LINER:** molded high impact polystyrene.

**SOAP VALVE:** chrome-plated brass with ABS mechanism. Internal Buna-N check valves prevent leakage. Requires less than 5 lbs. of force to dispense soap.

## Capacity

32 oz. liquid soap.

## Operation

Soap dispenser slides open for filling and cleaning. Sight gauge indicates refill time. Valve dispenses measured amount of liquid soap. Requires less than 5 lbs. of force to dispense soap.

- Bradley liquid soap valves operate best with any vegetable oil or coconut oil hand soap having a 10–15% soap concentration.

## Installation

Verify all rough-in dimensions prior to installation. Requires rough wall opening 8-1/2"W x 4-1/2"H x 4"D. Secure to framing with mounting screws (included) at holes provided. Shim at screw points as required.

## Guide Specification

Recessed liquid soap dispenser shall be fabricated of stainless steel with exposed surfaces in satin finish. Faceplate of 5/16" thick solid laminate and secured by tumbler lock. Requires less than 5 lbs. of force to dispense soap. Capacity: 32 oz. liquid soap.

**Overall dimensions: 10-1/4"W x 6-1/4"H x 4"D.**

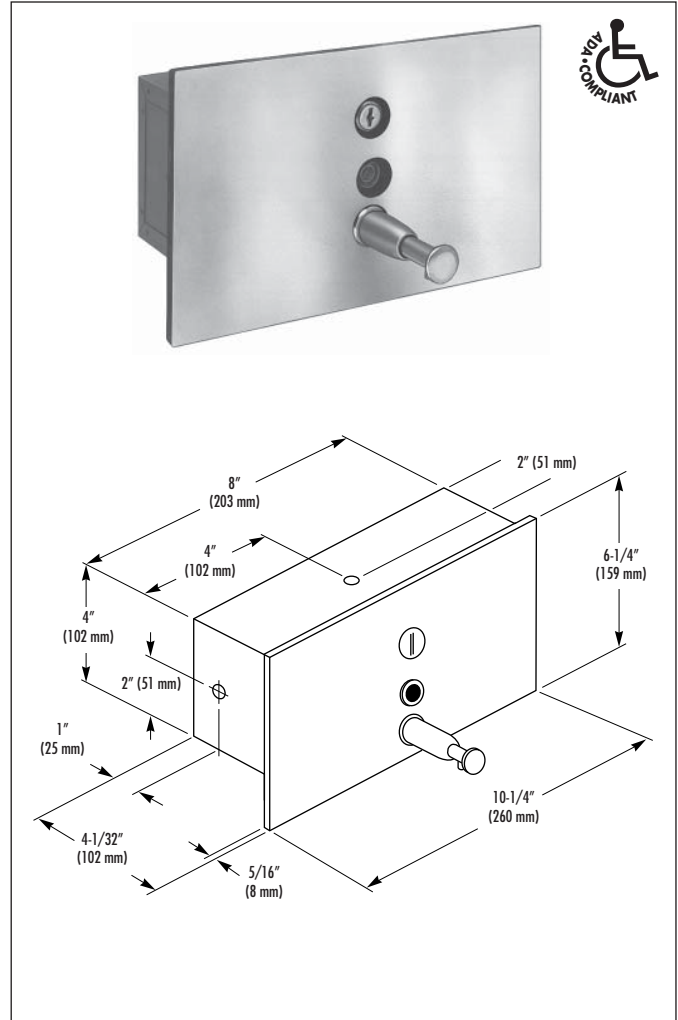

## ADA Compliant

- Consult local and national accessibility codes for proper installation guidelines.
- Conformity and compliance to local and national codes is the responsibility of the installer.

Washroom Accessories  
Document No. 8655

Distributed by  
**www.Ameraproducts.com**

Phone: (800) 608-6568  
Fax: (409) 840-5545  
info@ameraproducts.com