



AMERICAN SPECIALTIES, INC.

MODEL No: 0361

ISSUED: 7-05

REVISED: 9-05

SURFACE MOUNTED AUTOMATIC SOAP DISPENSER

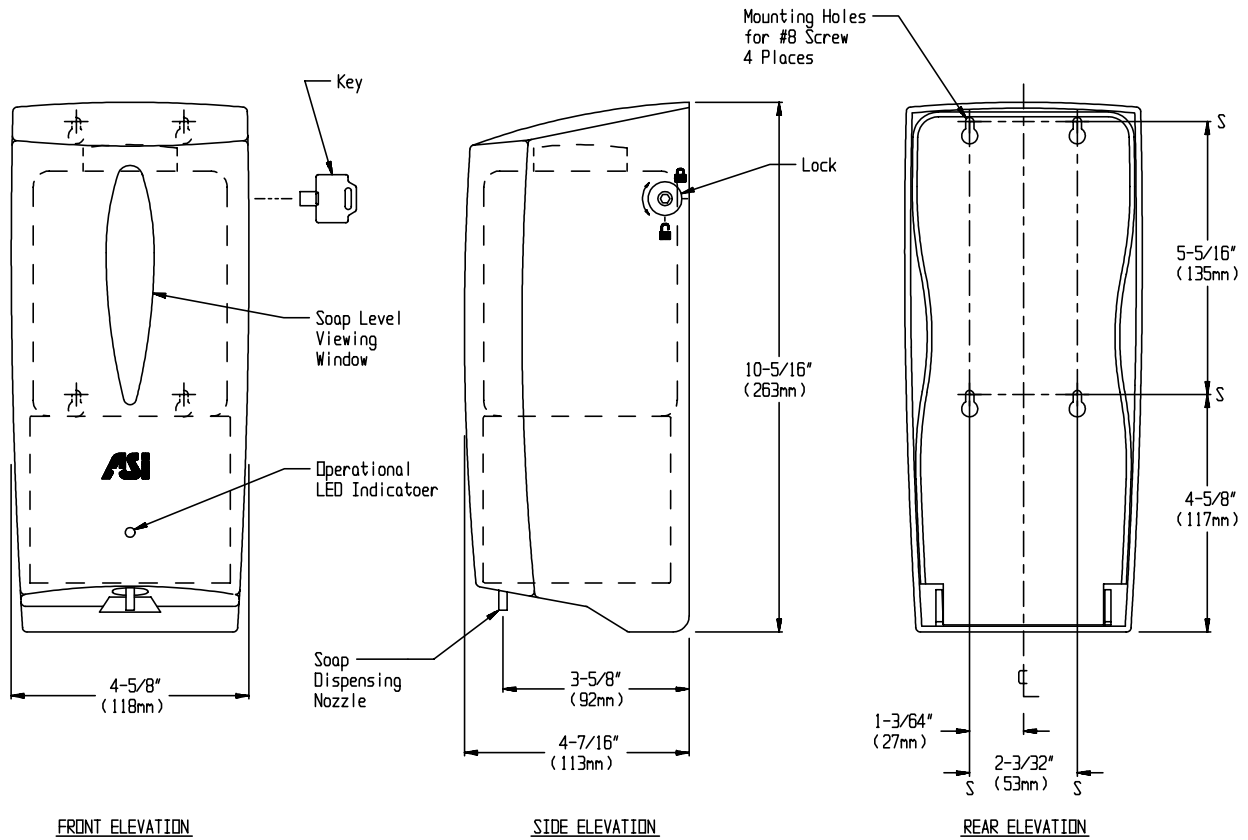

SPECIFICATION

Surface Mounted Automatic Liquid Soap Dispenser shall hold and dispense up to 800ml (27 oz) of liquid and lotion soaps, synthetic detergents and antibacterial soaps containing PCMX and/or Triclosan with a viscosity range of between 5 and 3500 mPa·s or cP (MilliPascal-sec or Centipoise). Dispenser body shall be molded of white high impact plastic. Dispenser shall be powered by either one (1) 9 V or six (6) AA-size (1.5 V) batteries (not supplied) and shall operate automatically from IR sensor that shall activate soap dispensing when hands are placed in sensor zone. Sensor detection range shall be self adjusting. Dispenser shall have two (2) soap dosage settings and shall pump either of two preset ranges of .02 ± .01 fl oz or .04 ± .01 fl oz (.5 ml to .7 ml or 1ml to 1.4 ml) of soap during each activation. A tamper resistant soap level viewing window shall be provided. Unit shall have a swing open body secured with side mounted lock which is opened with special key provided.

Surface Mounted Automatic Liquid Soap Dispenser shall be Model N° 0361 of American Specialties, Inc.,

INSTALLATION

Unit is surface mounted to wall or partition by means two (2) N°8 screws. Recommended installation for general utility is 42" (1067 mm) to 46" (1168mm) AFF and 10" (254mm) minimum above wash basin or countertop. A mounting template is provided.

OPERATION

Soap is automatically dispensed when hands are placed in sensor zone. Owner sets soap dosage range manually inside housing. Unit is reloaded by unlocking lock with special key (supplied), swinging open dispenser body and removing and refilling internal soap container. Soap dispenser will continue to feed properly until empty. Tank supply is replenished manually on cycle determined by maintenance needs. A complete instruction sheet is provided with each unit.

Accessory Specialties

AMERICAN DISPENSER

Desert Ray Products

WATROUS INC.