

SAFETY GRAB BAR - EXTERIOR MOUNTED - RSCBB-Y INSTALLATION & MAINTENANCE GUIDE | 14I-417

GENERAL:

The Safety Grab Bar offers safety while entering and exiting the roof hatch, regardless of weather conditions. It is always right in place, ready for use. Easily retrofitted with its universal mounting on either the right or left side of the roof hatch curb corner into the counterflashing, so it does not penetrate the roof membrane.

TOOLS NEEDED:

(provided by others)

- Screw driver or power drill
- T30 Torx bit (needed when using 1/4-20 x 3/4" screws)
- 7/32" Drill bit
- 9/16" Wrench (needed when using 3/8" hardware)

INSTALLATION:

Note: If not installing on a roof hatch with matching pre-drilled holes, measure and drill 7/32" holes before installing the Safety Grab Bar.

1. Align the Safety Grab Bar to desired corner and in line with pre-drilled holes. Recommended to install grab bar on same side as the hold open arm. (Fig. 1)
2. Fully fasten one plate with provided screws (either the round head torx 1/4-20 x 3/4" or the hex head 3/8-16 x 3/4") then fasten the other plate. (Fig. 2 & 3)
3. Confirm the grab bar is secured by pulling in different directions.

OPERATION:

Assure that all screws are tightened properly. The Safety Grab Bar should be secure. The roof hatch should operate without interfering with the grab bar.

MAINTENANCE:

It is recommended that the screws be checked periodically and tightened as needed.

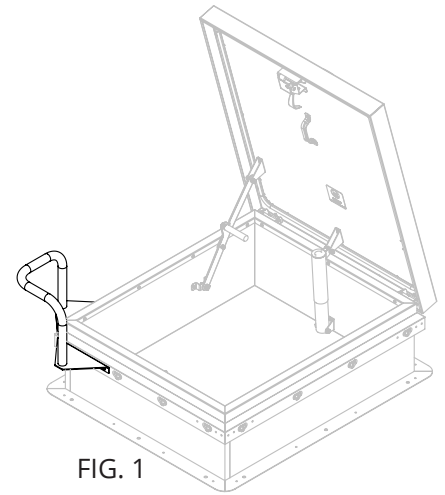

FIG. 1

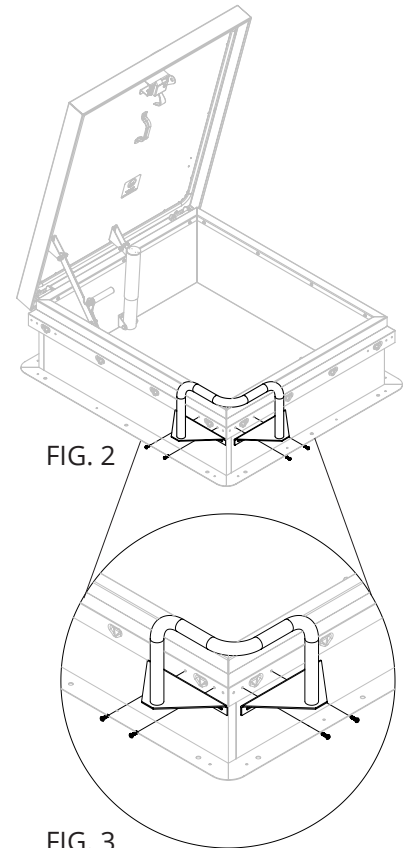

FIG. 2

FIG. 3
Close up view



JL INDUSTRIES



MAXAM
METAL PRODUCTS



DUR-RED
PRODUCTS

9702 Newton Ave S. Bloomington, MN 55431 | Many Locations Across North America

Installation &
Maintenance Guide

14I-417

REV A 3-04-2024