

**INTEGRATED PRIVACY™ SYSTEM  
POWDER COATED AND  
STAINLESS STEEL PARTITIONS**

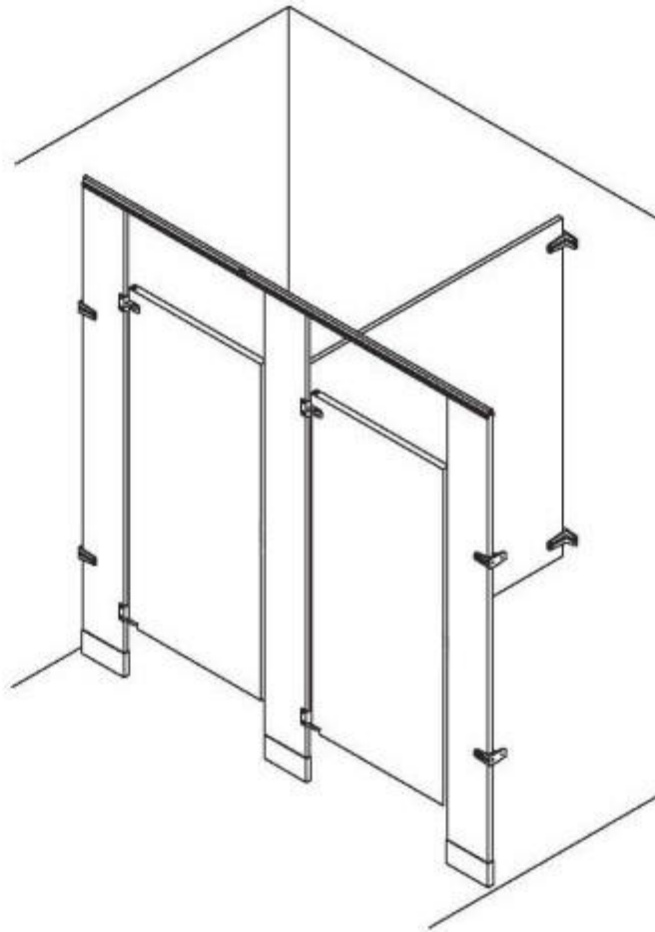

*Thank you for choosing ASI Accurate Partitions*

*This installation guide was designed to cover as many variations of hardware and mounting styles as possible, while also trying to keep it light and focused.*

*While all materials and standard mounting selections are present, in order to cover the numerous choices of hardware, we have presented each material with it's default hardware. Therefore, while each type is covered, it will be with it's most common mounting style (i.e. continuous brackets on ceiling-hung, piano hinges on Solid Plastic (HDPE), etc).*

*Please read all steps in their entirety before beginning actual install, as some field conditions and hardware combinations may require alternate installation.*

## Table of Contents

<u>Floor Anchored/Overhead Braced</u>	<u>Page</u>
Step 1,2,3.....	1
Step 3,4,5.....	2
Panel to Pilaster/Wall Two Ear Assembly.....	3
Panel to Pilaster/Wall One Ear Assembly.....	4
Pilaster/Wall One Ear Assembly.....	5
Pilaster/Panel Alcove Assembly.....	6
Pilaster/Panel Inline Assembly.....	7
Door Hardware Assembly (Typical All Styles).....	8A-8B
Headrail Assembly.....	9
Urinal Screen Assembly.....	10
 <u>Floor Anchored</u>	
Step 1,2,3.....	11
Step 3,4,5.....	12
Panel to Pilaster/Wall Two Ear Assembly.....	13
Panel to Pilaster/Wall One Ear Assembly.....	14
Pilaster/Wall One Ear Assembly.....	15
Pilaster/Panel Alcove Assembly.....	16
 <u>Ceiling Anchored</u>	
Step 1,2,3.....	17
Step 3,4,5.....	18
Panel to Pilaster/Wall Two Ear Assembly.....	19
Panel to Pilaster/Wall One Ear Assembly.....	20
Pilaster/Wall One Ear Assembly.....	21
Pilaster/Panel Alcove Assembly.....	22

Table of Contents

<u>Floor Anchored and Ceiling Anchored</u>	<u>Page</u>
Step 1,2,3.....	23
Step 3,4,5.....	24
Panel to Pilaster/Wall Two Ear Assembly.....	25
Panel to Pilaster/Wall One Ear Assembly.....	26
Pilaster/Wall One Ear Assembly.....	27
Pilaster/Panel Alcove Assembly.....	28
Pilaster/Panel Inline Assembly.....	29
 <u>Full Height Bracket Kits</u>	
Panel to Pilaster/Wall Two Ear Assembly.....	30
Panel to Pilaster/Wall One Ear Assembly.....	31
Pilaster/Wall One Ear Assembly.....	32
Urinal Screen Assembly .....	33
 <u>Product Information</u>	
Care and Maintenance of Toilet Partitions.....	34

*The Components for this project have been custom fabricated. They are guaranteed with respect to manufacture and workmanship and were inspected at the factory.*

*Before beginning work, the units should be inspected. If damage occurred in transit, report immediately to the freight company or other agencies that may have caused the damage.*

**STEP 1  
FLOOR ANCHORED/OVERHEAD BRACED**

- A. Review the layout drawings and package lists that have accompanied this job.
- B. Before proceeding, confirm that backing of walls and floor is adequate to support secure mounting of the toilet compartment units.
- C. Establish and mark pilaster center line from back wall.
- D. Establish and mark panel center lines for wall brackets.
- E. Establish pilaster floor fastener locations from side wall according to shop drawings. (Note floor fasteners are located 1" from lockstrip edge of pilaster.)
- F. Mark wall bracket holes using the brackets as templates.

**FIGURE 1**

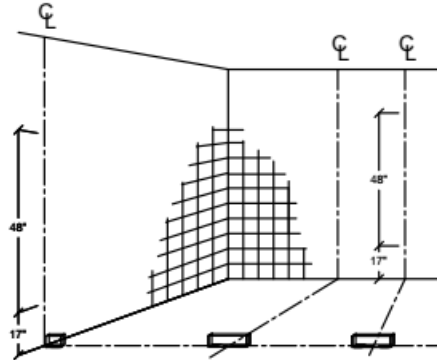

**STEP 2  
WALL BRACKETS AND FLOOR BRACKETS**

- A. Drill holes for wall brackets and floor fastenings of appropriate size for particular fastening devices supplied.
- B. Insert anchoring devices in walls and secure wall brackets.
- C. Insert expansion shields or other floor fastening devices, position shoe clips and "L" brackets over expansion shields and secure loosely with screws.

**FIGURE 2**

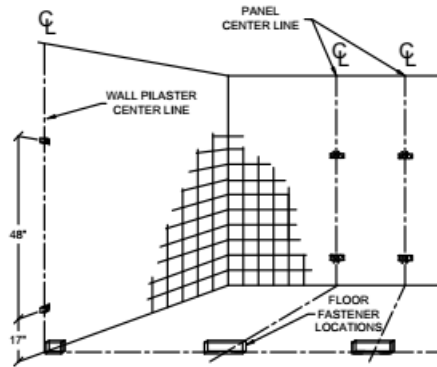

**STEP 3  
POSITION PANEL**

- A. Place panel on a support, 12" above the floor.
- B. Set it into wall brackets, but do not fasten panel at this time.

**FIGURE 3**

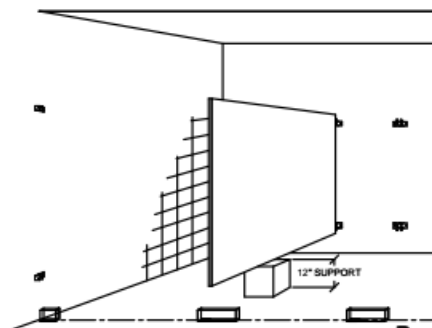

## **STEP 4** **PILASTER PREPARATION**

- A. Align U-brackets in position on rear of pilasters. Refer to layout drawings and make sure brackets are in alignment with wall brackets.
- B. Fasten U-brackets to pilaster with sheet metal screws.

**NOTE:** Pilasters at wall do not require U-brackets, but should be prepared for wall (and floor fastening) as required by compartment layout. If floor fastening is omitted, three wall brackets should be used.

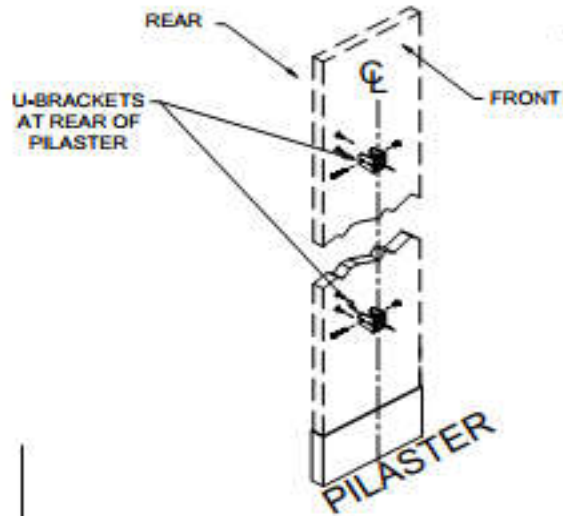
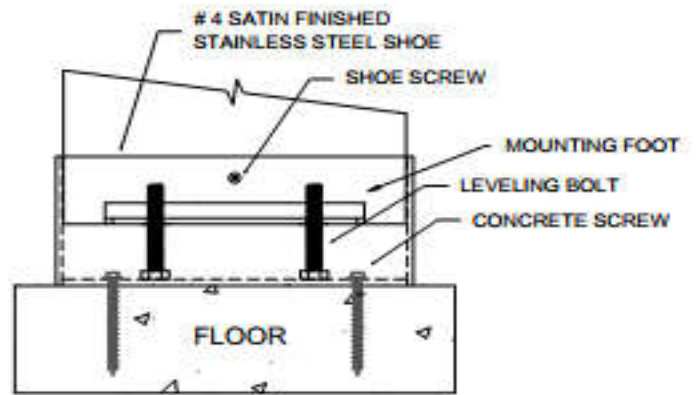

**FIGURE 4**

## **STEP 5** **INSTALL PILASTERS**

- A. Insert the leveling bolt into the threaded mounting foot at the bottom of the pilaster.
- B. Insert the pilaster into the shoe.
- C. Level the top of all pilasters by adjusting the leveling bolt to desired position.

**Note:** To determine how far to insert the leveling bolt, find the highest point on the floor, and fully insert the bolt on the pilaster that will be mounted in that location. Adjust all other leveling bolts accordingly.



**FIGURE 5**

## **STEP 6** **SECURING PILASTERS/PANELS**

- A. Plumb each pilaster and fasten the pilaster to panel using through bolts with barrel nuts or sheet metal screws.
- B. Establish door openings by setting pilaster mounting.
- C. Tighten self tapping screw to "L" brackets.
- D. Slide stainless steel shoe down to floor level, firmly engaging shoe clips.
- F. Remove panel support device.

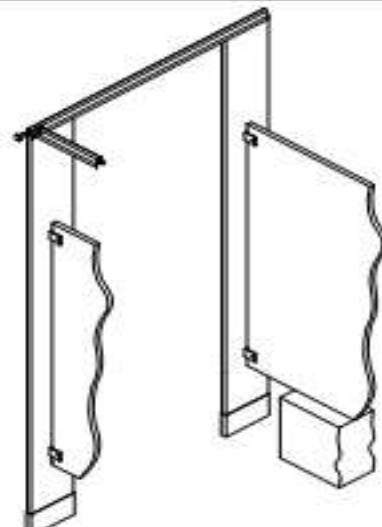

**FIGURE 6**





**FLOOR ANCHORED/OVERHEAD BRACED  
PANEL TO PILASTER/WALL  
TWO EAR ASSEMBLY**

Fasten pilaster to panel using sheet metal screws (Refer to steps 4 & 6)

Pre-drill for screws with 1/8" bit.

Pilasters must be both plumb and level. To assist in leveling, headrail may be lightly positioned across adjacent pilasters (do not fasten at this time)

Remove support device.

Panel Hardware Kit (P/N 40-8515020G) Includes: CHROME PLATED ZAMAC		
Panel Hardware Kit (P/N 40-8265021G) Includes: STAINLESS STEEL		
PART ID.	DESCRIPTION	QTY
1	 Two Ear Bracket	(2)
2	 "U" Bracket	(2)
3	 Vandal Resistant 2 1/2" S.M.S.	(4)
4	 Plastic Shields	(4)
5	 Vandal Resistant 5/8" S.M.S.	(12)

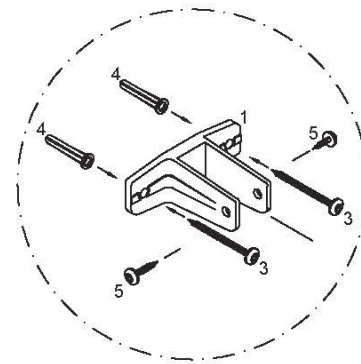
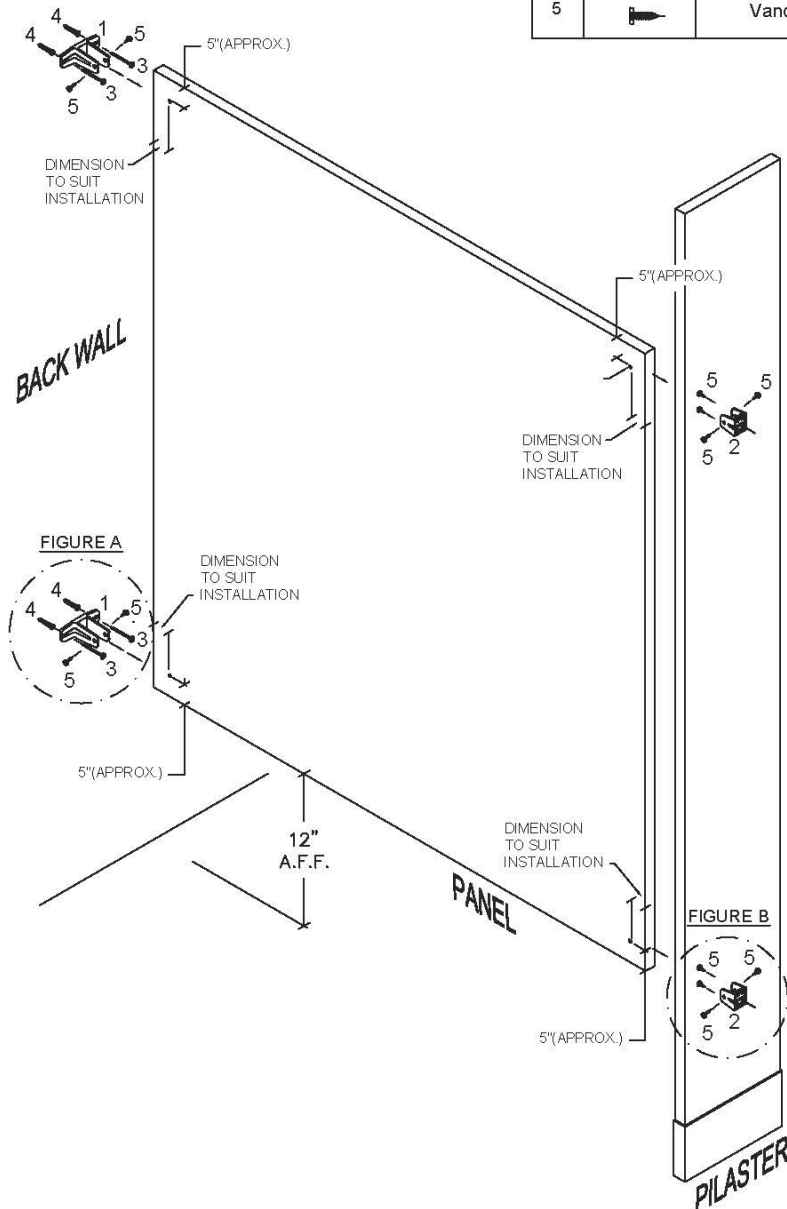

**FIGURE A**

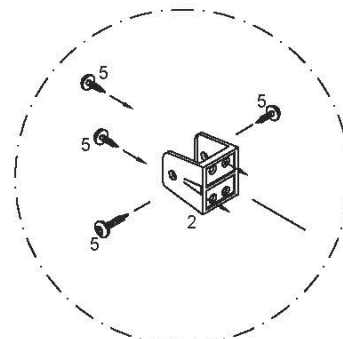

**NOTE:**  
Use Only Two Vandal Resistant 5/8" SMS  
To Diagonally Fasten U-bracket  
To Pilaster.

**FIGURE B**



**FLOOR ANCHORED/  
OVERHEAD BRACED  
PANEL TO PILASTER/WALL  
ONE EAR ASSEMBLY**

Fasten pilaster to panel using sheet metal screws(Refer to steps 4 & 6 )

Pre-drill for screws with 1/8" bit.

Pilasters must be both plumb and level. To assist in leveling, headrail may be lightly positioned across adjacent pilasters(do not fasten at this time)

Remove support device.

Panel Hardware Kit (P/N 40-8515010G) Includes: CHROME PLATED ZAMAC			
Panel Hardware Kit (P/N 40-8265011G) Includes: STAINLESS STEEL			
PART ID.		DESCRIPTION	QTY
1		One Ear Bracket	(2)
2		"U" Bracket	(2)
3		Vandal Resistant 2 1/2" S.M.S	(4)
4		Plastic Shields	(4)
5		Vandal Resistant 5/8" S.M.S	(12)

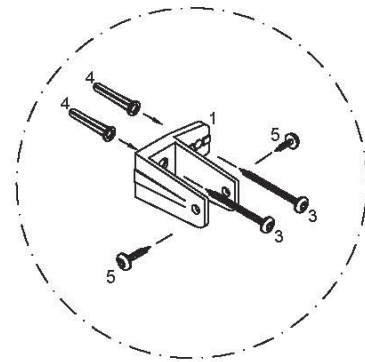
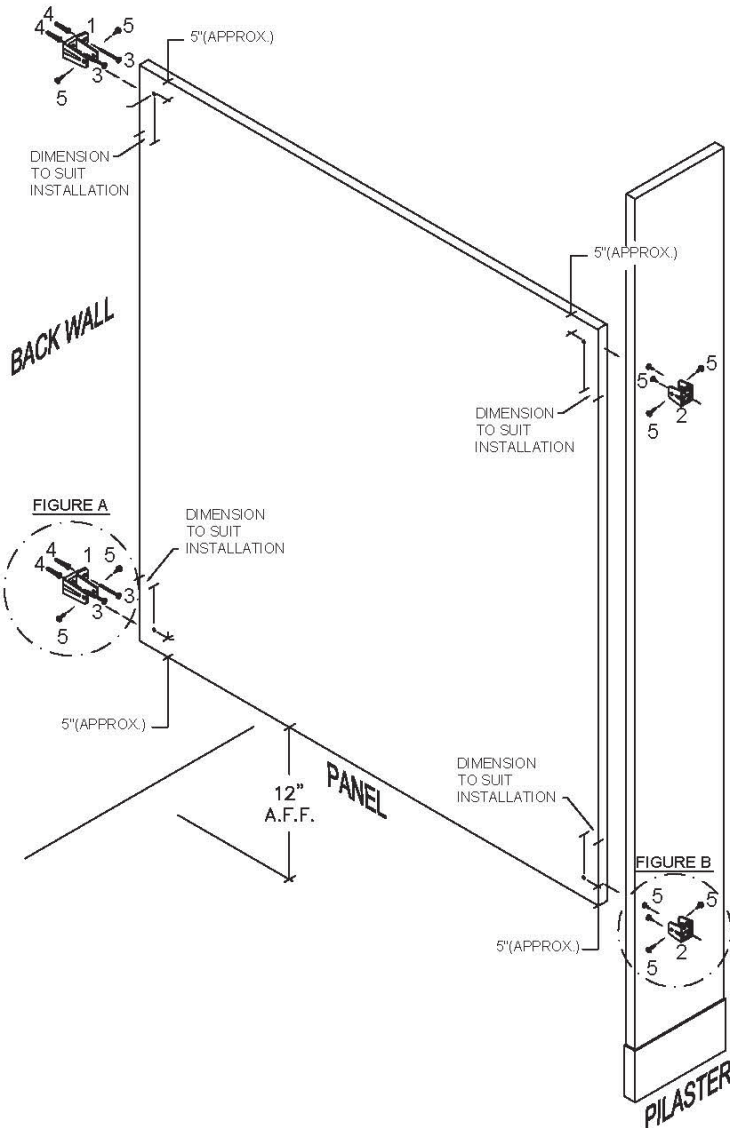

**FIGURE A**

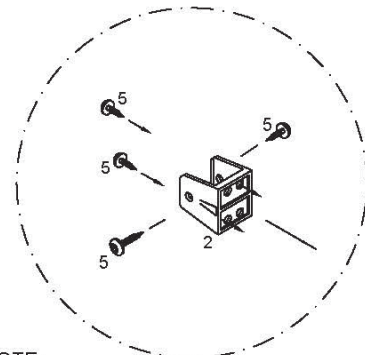

**FIGURE B**

**NOTE:**  
Use Only Two Vandal Resistant 5/8" SMS  
To Diagonally Fasten U-bracket To Pilaster.



## FLOOR ANCHORED/OVERHEAD BRACED PILASTER/WALL ASSEMBLY

Fasten using sheet metal screws.

Pilasters must be both plumb and level. To assist in leveling, headrail may be lightly positioned across adjacent pilasters(do not fasten at this time)

Establish bottom door openings by adjusting pilaster "L" brackets (anchoring) to desired position and tightening screws.(See step 6)

Pilaster/Wall Hardware Kit (P/N 40-8515210G) Includes: CHROME PLATED ZAMAC		
Pilaster/Wall Hardware Kit (P/N 40-8265211G) Includes: STAINLESS STEEL		
PART ID.	DESCRIPTION	QTY
1	 One Ear Wall Bracket	(2)
2	 Vandal Resistant 2 1/2" S.M.S	(4)
3	 Plastic Shields	(4)
4	 Vandal Resistant 5/8" S.M.S	(8)

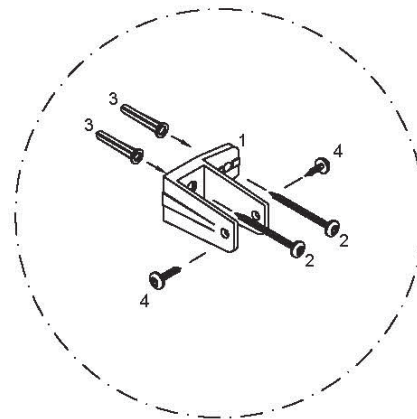
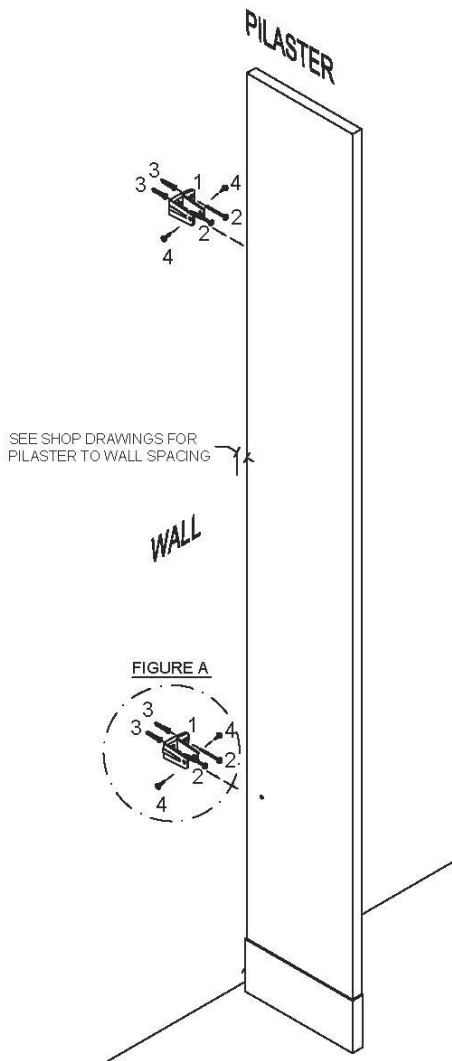
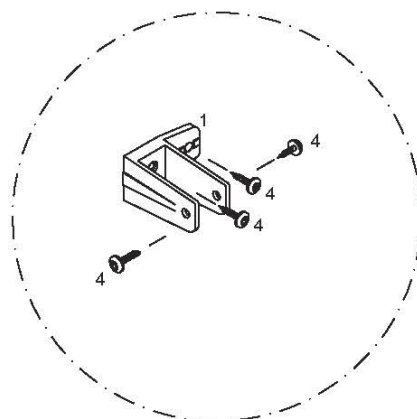

FIGURE A



ALTERNATE

**NOTE:**  
Replace Vandal Resistant 2 1/2" SMS  
With Vandal resistant 5/8"SMS  
To Fasten Pilaster To Panel.

**FLOOR ANCHORED/  
OVERHEAD BRACED  
PILASTER/PANEL ALCOVE  
ONE EAR ASSEMBLY**

Note: CHROME PLATED  
Replace Kit#8517310 with Kit#8517320  
for two ear panel locations.

Note: STAINLESS STEEL  
Replace Kit#8267311 with Kit#8267321  
for two ear panel locations.

Alcove Hardware Kit (P/N 40-8517310G) Includes: CHROME PLATED ZAMAC			
Alcove Hardware Kit (P/N 40-8267311G) Includes: STAINLESS STEEL			
PART ID.		DESCRIPTION	QTY
1		1 1/4" One Ear Wall Bracket	(2)
2		Vandal Resistant 2 1/2" S.M.S	(10)
3		Plastic Shields	(10)
4		Vandal Resistant 5/8" S.M.S	(14)
5		Alcove Clip	(2)
6		1" One Ear Wall Bracket	(2)
7		Vandal Resistant 1" S.M.S	(4)
8		Bracket Headrail Satin "F" Zamac	(1)

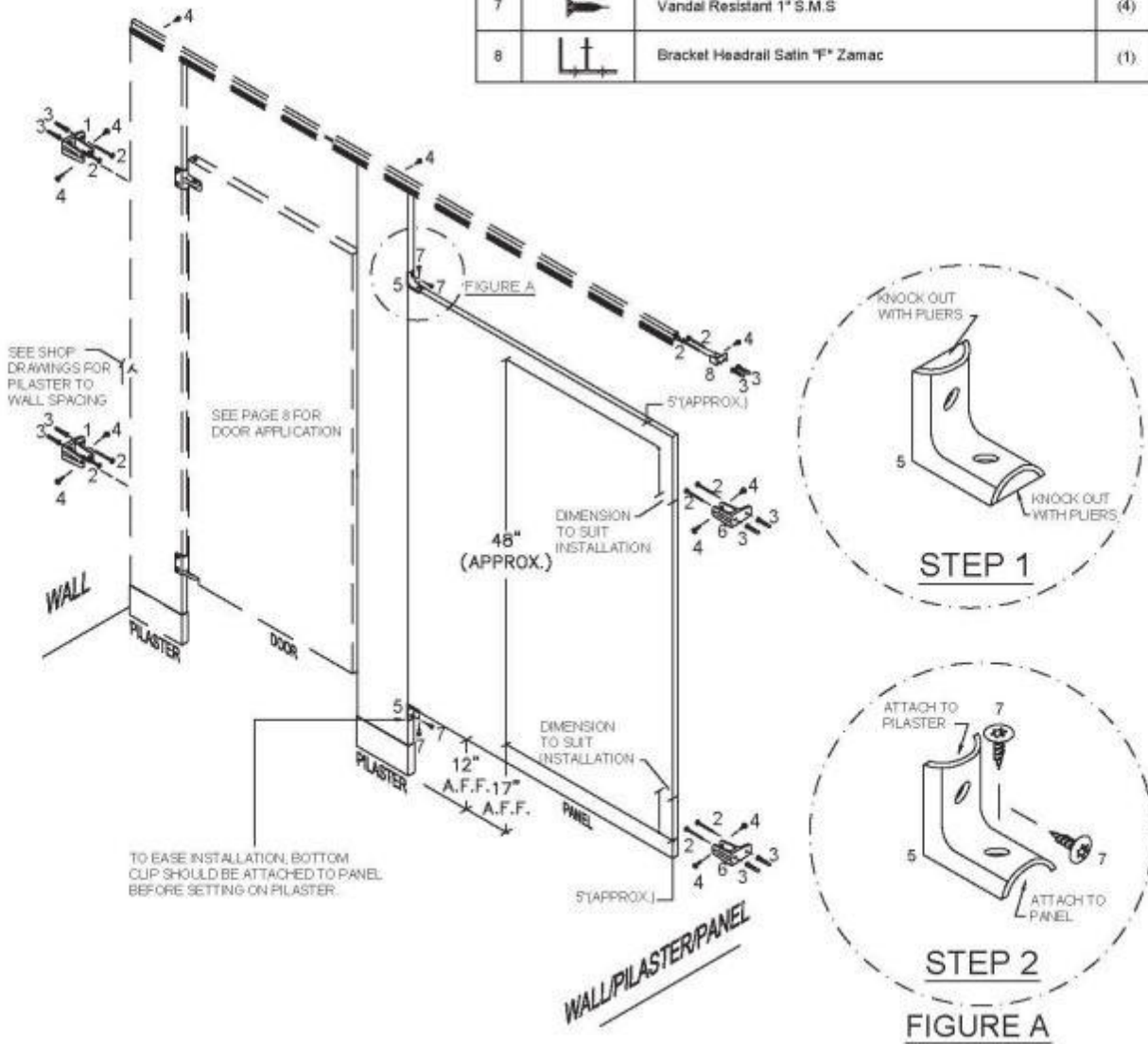

Distributed by  
www.Ameraproducts.com  
Phone: (800) 608-6568  
FAX: (409) 840-5543  
info@ameraproducts.com

**FLOOR ANCHORED/  
OVERHEAD BRACED  
PILASTER/PANEL/PILASTER INLINE  
ASSEMBLY**

Alternate Alcove Hardware Kit (P/N 40-8517030G) Includes:  
**CHROME PLATED ZAMAC**

PART ID.	DESCRIPTION	QTY
1	 Alcove Clips	(12)
2	 Vandal Resistant Step Bolts 1" Long	(12)
3	 Vandal Resistant Barrel Nut	(12)
4	 Vandal Resistant 5/8" S.M.S	(24)

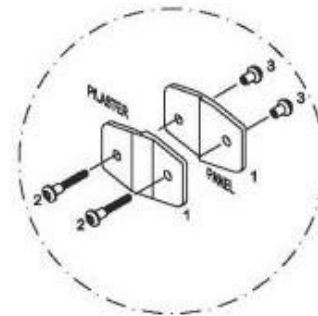
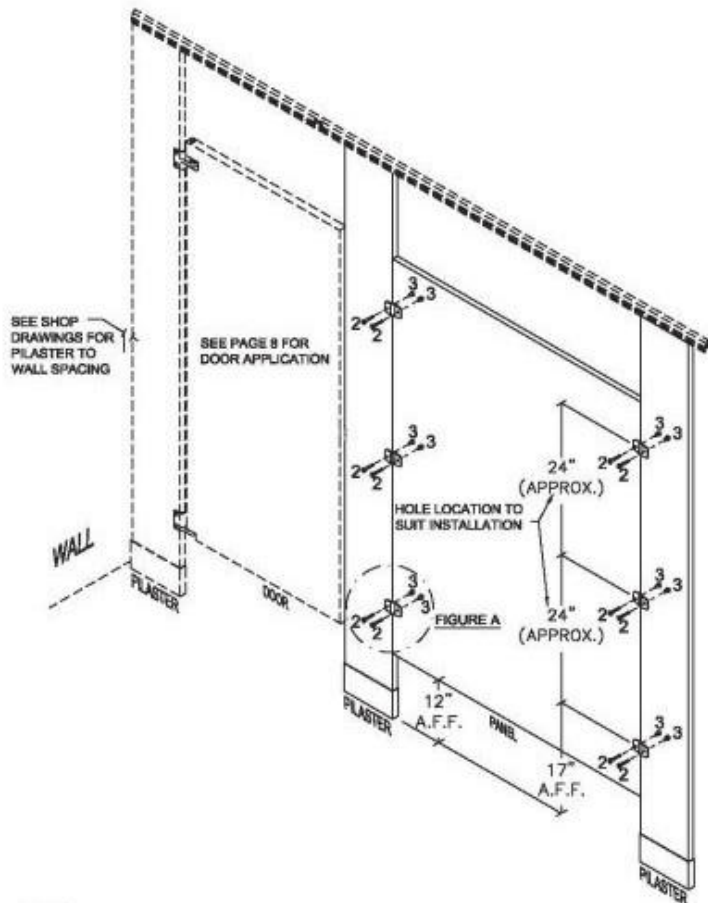

**FIGURE A  
RECOMMENDED**

**NOTE:**  
Offset brackets for screw clearance.

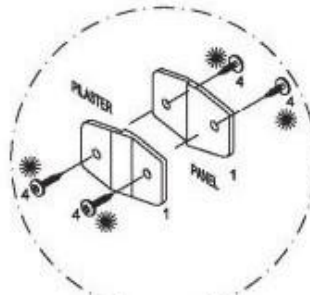

**OPTIONAL**

**OPTIONAL**  
Two Vandal Resistant 5/8" S.M.S  
May be Used (But Not Recommended)  
To Fasten brackets To Panel.

**NOTE:**  
Replace Theft Resistant C/P 2 1/2"  
With Theft resistant C/P 5/8"  
To Fasten Pilaster To Panel Instead Of A Wall  
Should Your Layout Call For Such.

# ASI<sup>®</sup> Accurate Partitions

## DOOR HARDWARE ASSEMBLY

- A. Secure lower hinge to the pilaster with two through bolts & two barrel nuts.
- B. Secure upper hinge to pilaster with two through bolts and two barrel nuts.
- C. Insert box cam into lower door hinge portion. The short key toward the edge of the door.
- D. Lowest point of cam pintle sets door "rest" position. Rotate pintle to desired position, then tighten locking nut.
- E. Install door by placing the box cam over the hinge pintle. Position top of door over upper pilaster hinge and insert hinge pin until flush with top of door.

Continued on Page 8B

PART ID.	DESCRIPTION	QTY
1	Top Hinge	(1)
2	Hinge Pin	(1)
3	Bottom Hinge	(1)
4	Hinge Pintle Nylon	(1)
5	Hinge Washer External	(1)
6	Hinge Washer Internal	(1)
7	Hinge Nut 5/16"	(1)
8	Box cam Nylon	(1)
9	Indicator Slide Latch Outside	(1)
10	Indicator Slide Latch Inside	(1)
11	Coat Hook & Bumper	(1)
12	Step Bolt 1-1/4"	(4)
13	Barrel Nut 5/8"	(4)
14	Screw #10 x 5/8"	(6)
15	Step Bolt 1"	(2)
16	Keeper	(1)
17	Door Pull Inside	(1)
18	Door Pull Outside	(1)
19	Indicator Drive Pin	(1)
20	Outswing Bumper	(1)
21	Step Bolt 1-1/2"	(2)
22	Pilaster	(1)
23	Door	(1)

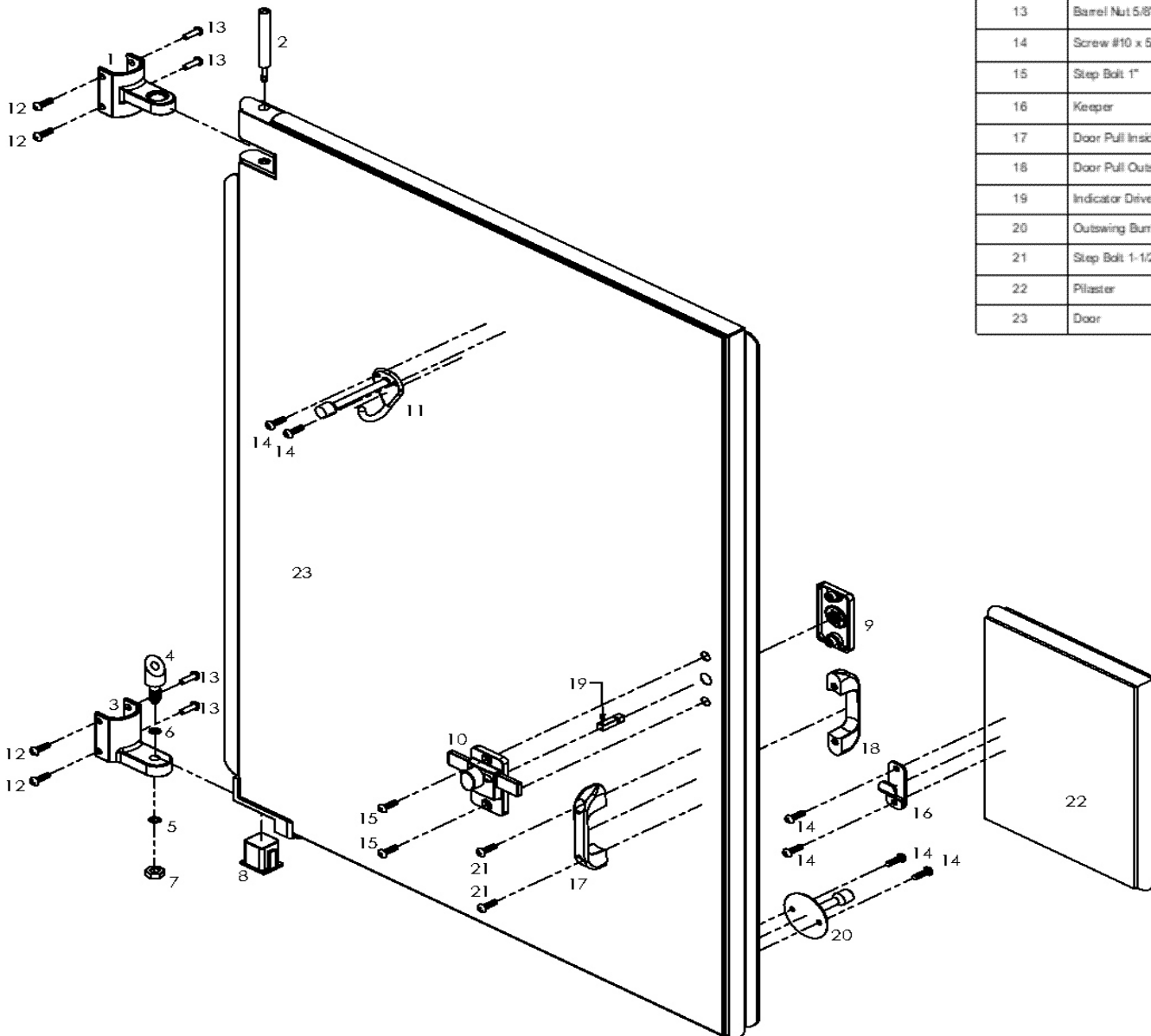

- F. Insert the indicator drive pin (#19) into the back of the indicator slide latch (#9).
  - G. Turn the indicator dial until the indicator window shows red.
  - H. Slide the handle of the indicator slide latch (#10) so that the latch will be in the locked position.
  - I. Align both halves of the indicator slide latch with the 3 predrilled holes in the door.
  - J. Secure the latch with two 1" step bolts (#15).
  - K. With the door closed and the latch engaged, align the keeper (#16) with the latch bar.
  - L. Drill two 9/64" holes in the pilaster using the keeper as a guide.
  - M. Attach the keeper to the pilaster using two 5/8" screws (#14).
  - N. Place the coat hook (#11) 10" from the top of the door and centered from side to side.
- Note:** Federal ADA guidelines recommend that the coat hook be no more than 48" above the floor. If the door swings in, place the bumper so that it strikes the wall before any other part of the door.
- O. Using the coat hook (#11) as a guide, drill two 9/64" holes, and secure the coat hook with two 5/8" screws (#14).
  - P. Place the inside door pull (#17) between 34" & 48" above the floor. Using the pull as a template, drill two 1/4" holes through the door.
  - F. Align both halves of the door pull (#17 & #18) with the 1/4" holes and secure them with two 1-1/2" step bolts (#21).
  - G. Place the outswing bumper (#20) near the bottom corner of the door on the strike side.
  - O. Using the bumper as a guide, drill two 9/64" holes, and secure the bumper to the door with two 5/8" screws (#14).

**Note:** Door pulls are provided for all outswing doors. Door pulls are provided for all ADA doors. Outswing bumpers are only provided for outswing doors.

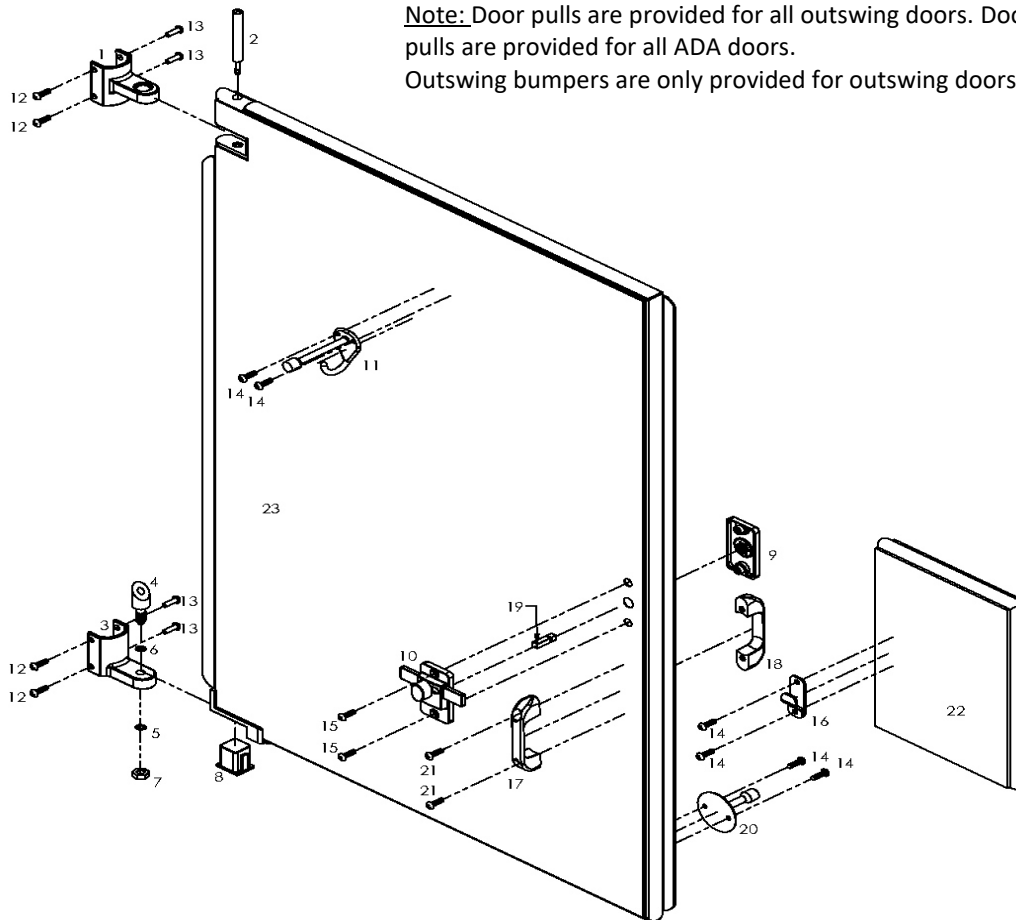

PART ID.	DESCRIPTION	QTY
1	Top Hinge	(1)
2	Hinge Pin	(1)
3	Bottom Hinge	(1)
4	Hinge Pin/ie Nylon	(1)
5	Hinge Washer External	(1)
6	Hinge Washer Internal	(1)
7	Hinge Nut 5/16"	(1)
8	Box cam Nylon	(1)
9	Indicator Slide Latch Outside	(1)
10	Indicator Slide Latch Inside	(1)
11	Coat Hook & Bumper	(1)
12	Step Bolt 1-1/4"	(4)
13	Barrel Nut 5/8"	(4)
14	Screw #10 x 5/8"	(6)
15	Step Bolt 1"	(2)
16	Keeper	(1)
17	Door Pull Inside	(1)
18	Door Pull Outside	(1)
19	Indicator Drive Pin	(1)
20	Outswing Bumper	(1)
21	Step Bolt 1-1/2"	(2)
22	Pilaster	(1)
23	Door	(1)



**HEADRAIL  
ASSEMBLY**

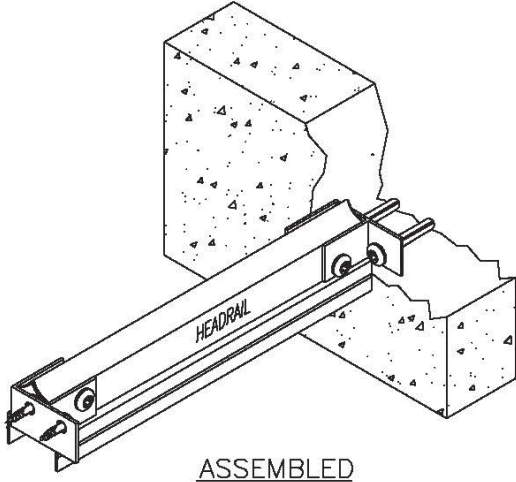

Headrail Hardware Kit (P/N 40-8448100G) Includes:

PART ID.	DESCRIPTION	QTY
1	 Headrail Satin "F" Zamac Bracket	(2)
2	 Headrail Cap Satin Zamac	(1)
3	 Vandal Resistant S/S 2 1/2" S.M.S	(2)
4	 Plastic Shield	(2)
5	 Vandal Resistant S/S 5/8" S.M.S	(4)

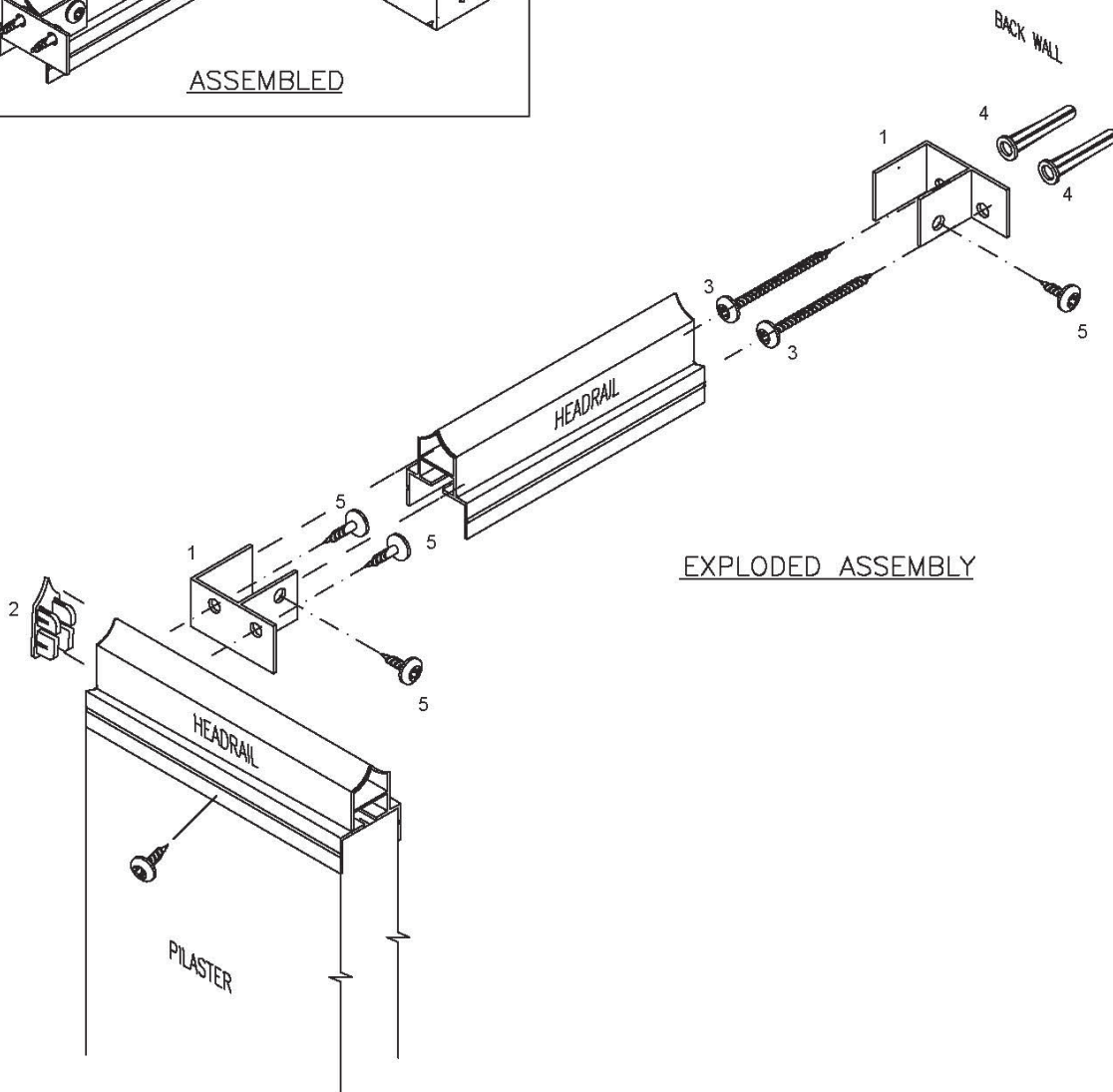



## URINAL SCREEN ASSEMBLY

- A. Before proceeding, confirm that backing of wall is adequate to support and secure mounting of urinal screens. Check dwgs for layout.
- B. Insert anchoring devices in walls and secure wall brackets with 2 1/2" s.m.s.
- C. Place urinal screen on a support, 12" above the floor.
- D. Set U/S into wall brackets and fasten urinal screen at this time, using 5/8" fasteners.

Urinal Screen Hardware Kit (P/N 40-8511281G) Includes: CHROME PLATED ZAMAC		
Urinal Screen Hardware Kit (P/N 40-8261281G) Includes: STAINLESS STEEL		
PART ID.	DESCRIPTION	QTY
1	 Two Ear Wall U/S Bracket	(2)
2	 Vandal Resistant 2 1/2" S.M.S	(4)
3	 Plastic Shields	(4)
4	 Vandal Resistant 5/8" S.M.S	(8)

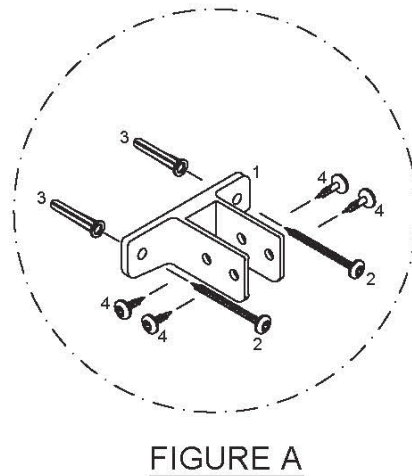
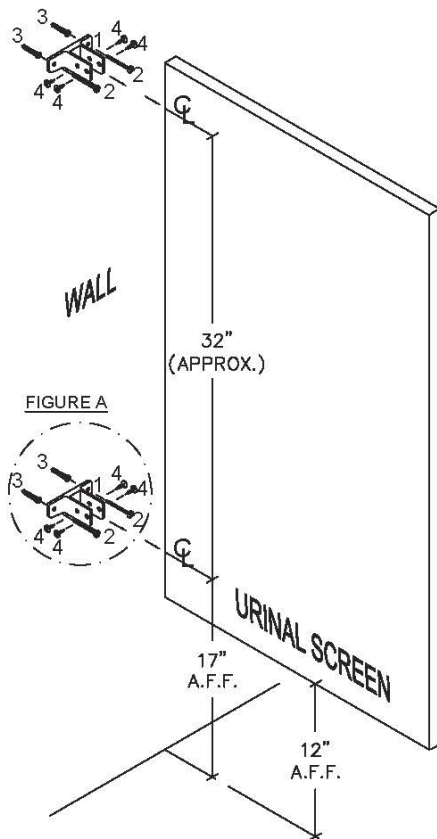
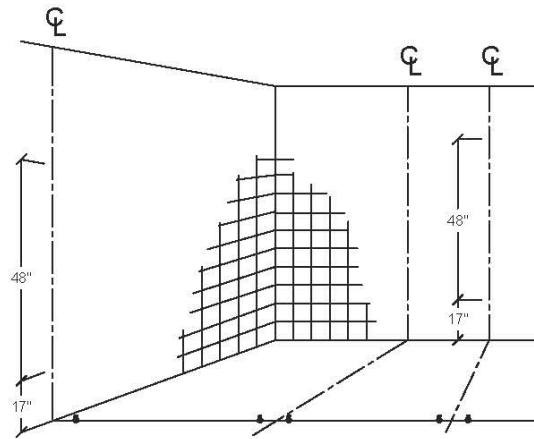

**FIGURE 1**

**STEP 1  
LAYOUT**

NOTE: FLOOR MUST BE CONCRETE.

- A. Review the layout drawings and package lists that have accompanied this job.
- B. Before proceeding, confirm that backing of walls and floor is adequate to support secure mounting of the toilet compartment units.
- C. Establish and mark pilaster center line from back wall.
- D. Establish and mark panel center lines for wall brackets.
- E. Establish pilaster floor fastener locations from side wall according to shop drawings. (Note floor fasteners are located 1" from edge of pilaster.)
- F. Mark wall bracket holes using brackets as templates.



**FIGURE 2**

**STEP 2  
WALL BRACKETS AND FLOOR BRACKETS**

- A. Drill holes for wall brackets of 1/4" and floor fastenings of 3/8" for fastening devices supplied.
- B. Insert anchoring devices in walls and secure wall brackets.
- C. Install wedge anchor with shoe clip washer and nut into concrete floor (min. 2 1/2") and tighten.

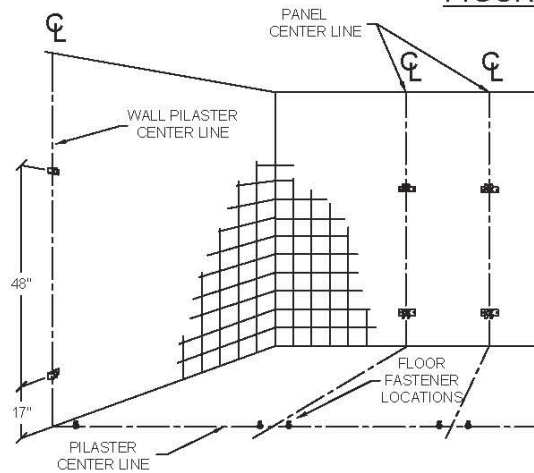

**FIGURE 3**

**STEP 3  
POSITION PANEL**

- A. Place panel on a support, 12" above the floor.
- B. Set it into wall brackets, but do not fasten panel at this time.

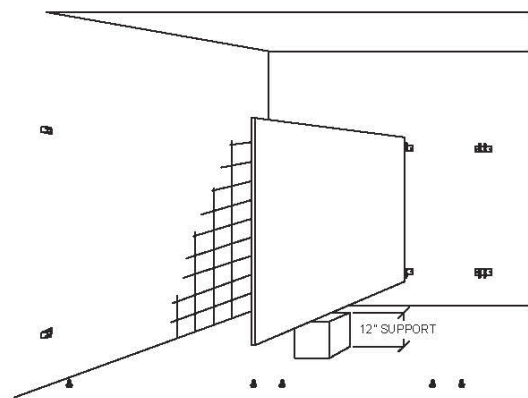

## STEP 4 PILASTER PREPARATION

- A. Align U-brackets in position on rear of pilasters. Refer to layout drawings for placement.
- B. Fasten U-brackets to pilaster with sheet metal screws pre-drilling with 1/8" bit.
- C. Pilasters at wall do not require U-brackets, but should be prepared for wall (and floor fastening) as required by compartment layout.

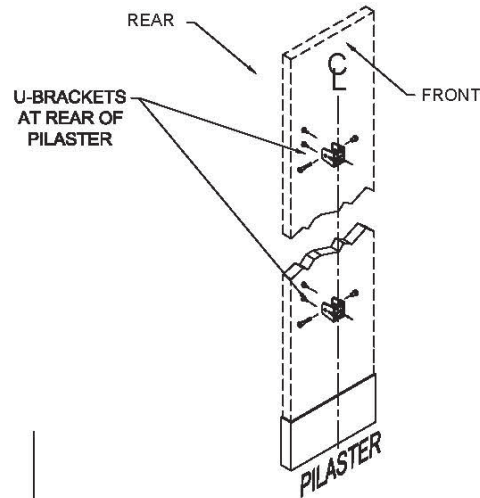

**FIGURE 4**

## STEP 5 INSTALL PILASTERS

- A. On each wedge anchor thread place one shoe clip and 3/8" support nut down to approximately 1" up from floor level and place round washer over each anchor.
- B. Inspect shoe for bowing. Squeeze edges and center of shoe to ensure shoe will not bow away from pilaster faces. Slide stainless steel shoe carefully over mounting end of pilaster and leave approximately 5" above end.
- C. Position pilaster on anchors and secure lightly with flat washers and 3/8" locking nuts.

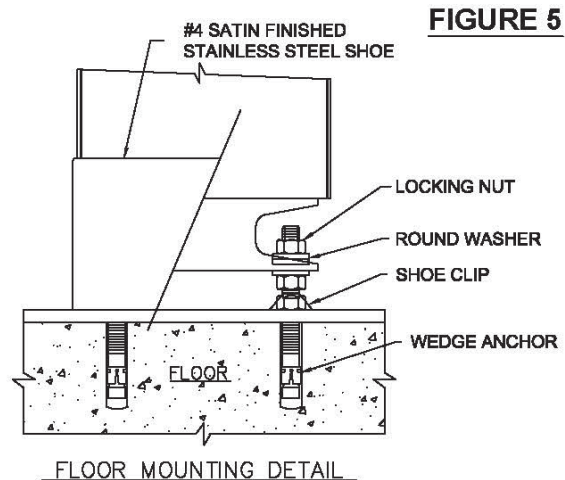

**FIGURE 5**

## STEP 6 SECURING PILASTERS /PANELS

- A. Level each pilaster by adjusting both support nuts to desired position.
- B. Plumb each pilaster and fasten the pilaster to panel with "u" brackets using through bolts or sheet metal screws.
- C. Establish door openings by setting pilaster mounting channel to desired position on anchor.
- D. Tighten locking nuts on top of pilaster mounting channel.
- E. Slide stainless steel shoe down to floor level, firmly engaging shoe clips.
- F. Remove panel support device.

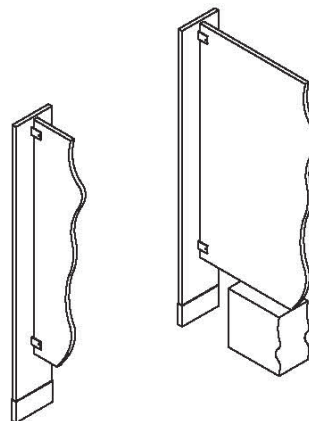

**FIGURE 6**

**FLOOR ANCHORED  
PANEL TO PILASTER/WALL  
TWO EAR ASSEMBLY**

Fasten pilaster to panel using sheet metal screws(Refer to steps 4 & 6 )

Pre-drill for screws with 1/8" bit.

Pilasters must be both plumb and level. To assist in leveling, headrail may be lightly positioned across adjacent pilasters(do not fasten at this time)

Remove support device.

Panel Hardware Kit (P/N 40-8515020G) Includes: CHROME PLATED ZAMAC			
Panel Hardware Kit (P/N 40-8265021G) Includes: STAINLESS STEEL			
PART ID.		DESCRIPTION	QTY
1		Two Ear Bracket	(2)
2		"U" Bracket	(2)
3		Vandal Resistant C/P 2 1/2" S.M.S	(4)
4		Plastic Shields	(4)
5		Vandal Resistant C/P 5/8" S.M.S	(12)

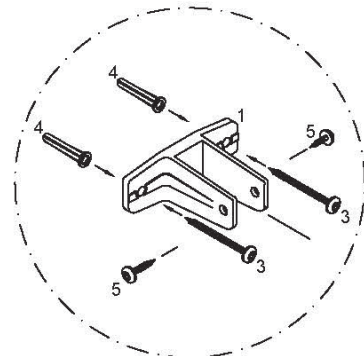
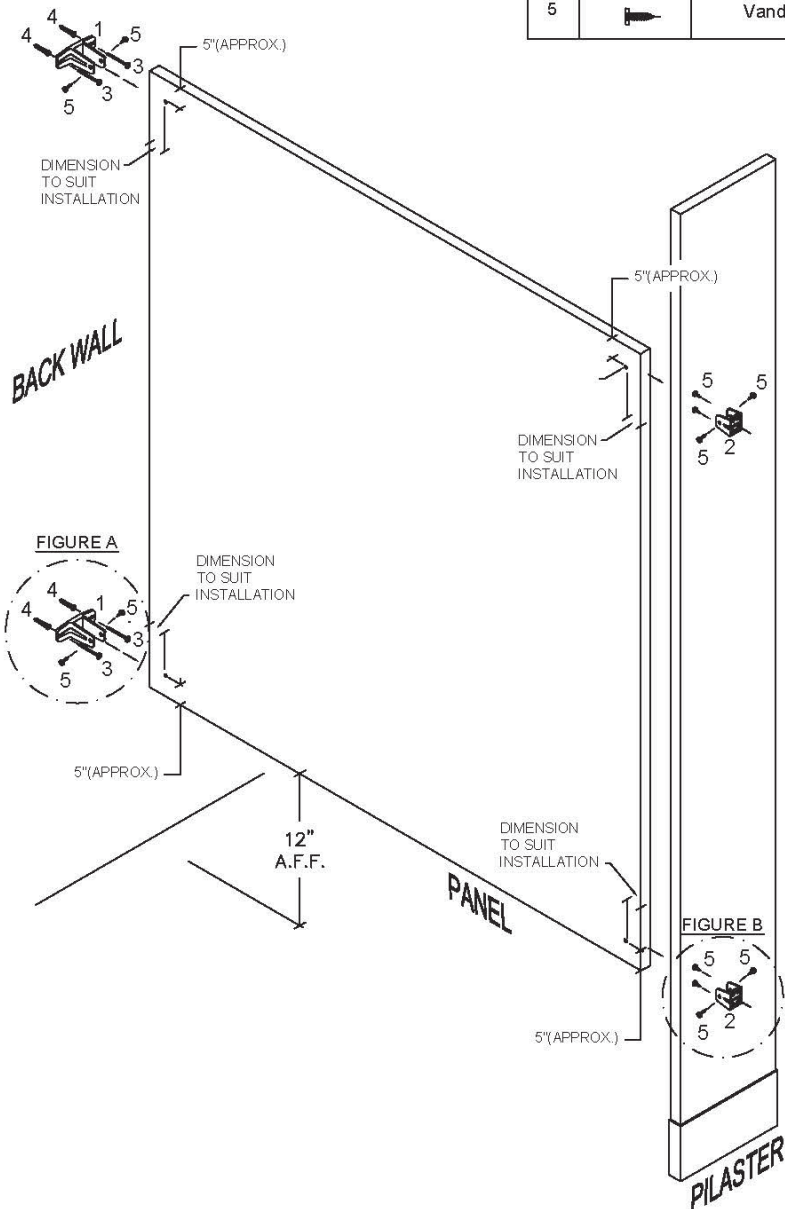

**FIGURE A**

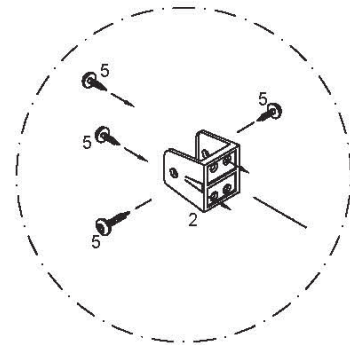

**FIGURE B**

**NOTE:**  
Use Only Two Vandal Resistant 5/8" SMS To Diagonally Fasten U-bracket To Pilaster.

**FLOOR ANCHORED  
PANEL TO PILASTER/WALL  
ONE EAR ASSEMBLY**

Pilasters must be both plumb and level.

- A. Plumb pilaster and fasten pilaster to panel using through bolts or sheet metal screws and "U" brackets.
- B. Establish bottom door openings by adjusting pilaster and tightening screws. (Refer to step 4 & 6)
- C. Remove support device.

Panel Hardware Kit (P/N 40-8515010G) Includes: CHROME PLATED ZAMAC		
Panel Hardware Kit (P/N 40-8265011G) Includes: STAINLESS STEEL		
PART ID.	DESCRIPTION	QTY
1	One Ear Bracket	(2)
2	"U" Bracket	(2)
3	Vandal Resistant 2 1/2" S.M.S	(4)
4	Plastic Shields	(4)
5	Vandal Resistant 5/8" S.M.S	(12)

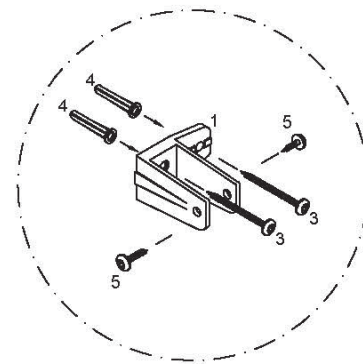
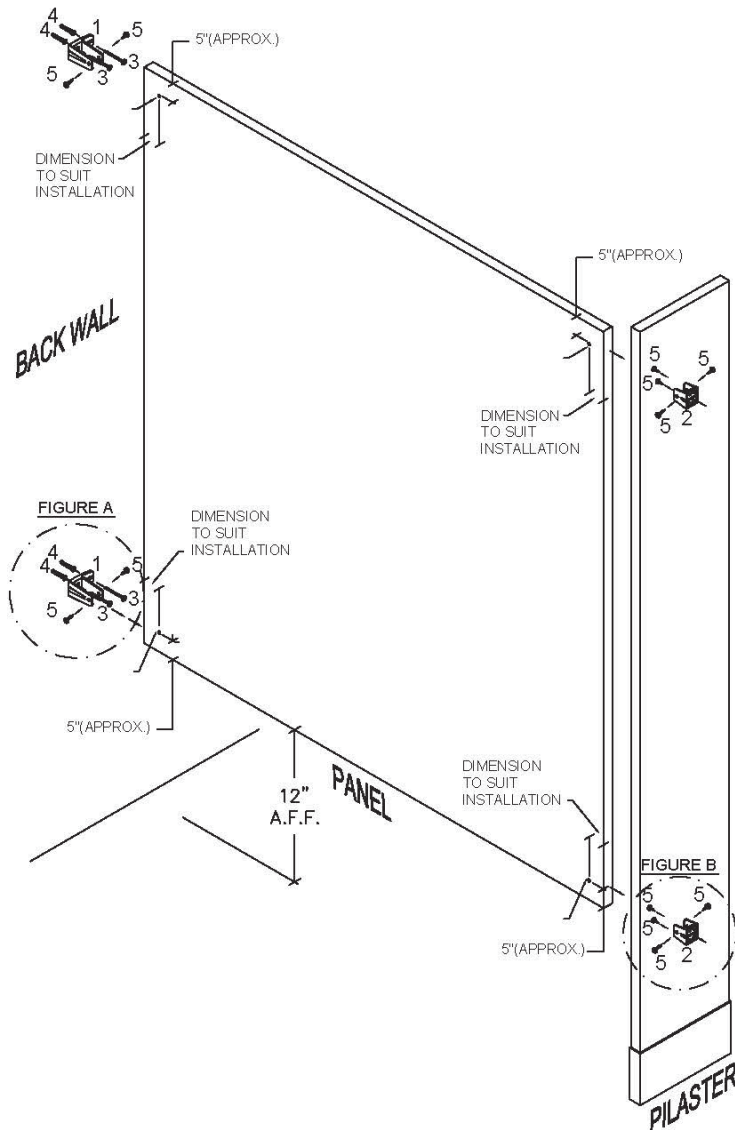

**FIGURE A**

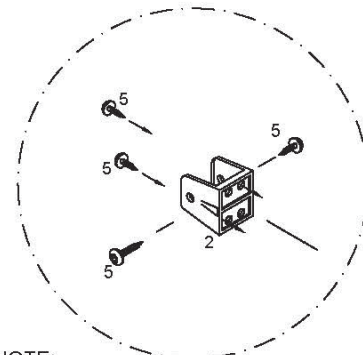

**NOTE:**  
Use Only Two Vandal resistant 5/8" SMS  
To Diagonally Fasten U-bracket To Pilaster.

**FIGURE B**





**FLOOR ANCHORED  
PILASTER/WALL ASSEMBLY**

Pilasters must be both plumb and level.

Pre-drill for screws with 1/8" bit.

Pilaster/Wall Hardware Kit (P/N 40-8515210G) Includes: CHROME PLATED ZAMAC		
Pilaster/Wall Hardware Kit (P/N 40-8265211G) Includes: STAINLESS STEEL		
PART ID.	DESCRIPTION	QTY
1	 One Ear Wall Bracket	(2)
2	 Vandal Resistant 2 1/2" S.M.S	(4)
3	 Plastic Shields	(4)
4	 Vandal Resistant 5/8" S.M.S	(8)

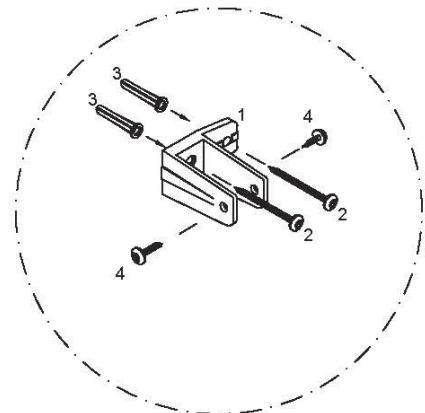
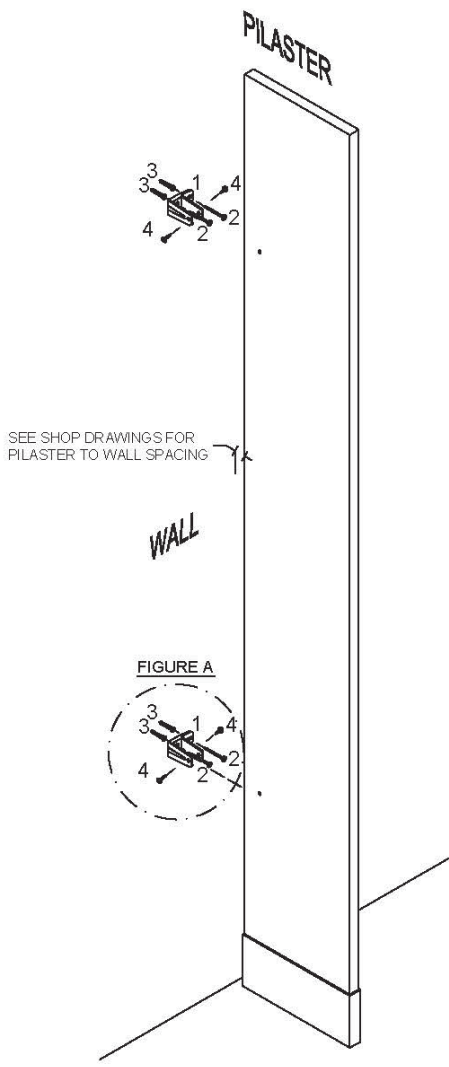

**FIGURE A**

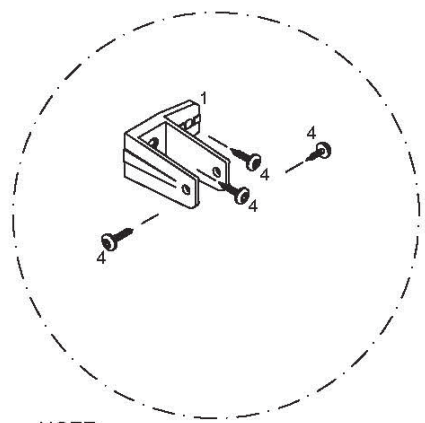





**NOTE:**  
Replace Vandal Resistant 2 1/2" SMS  
With Vandal Resistant 5/8" SMS  
To Fasten Pilaster To Panel Instead Of Wall.

**FIGURE B**



**FLOOR ANCHORED  
PILASTER/PANEL ALCOVE ASSEMBLY**

Note:  
Replace P/N#40-8515010G with P/N#40-8515020G  
for two ear locations.

Panel Hardware Kit (P/N 40-8515010G) Includes: CHROME PLATED ZAMAC		
Panel Hardware Kit (P/N 40-8265011G) Includes: STAINLESS STEEL		
PART ID.	DESCRIPTION	QTY
1	 One Ear Bracket	(2)
2	 "U" Bracket	(2)
3	 Vandal Resistant 2 1/2" S.M.S	(4)
4	 Plastic Shields	(4)
5	 Vandal Resistant 5/8" S.M.S	(12)

Pilaster/Wall Hardware Kit (P/N 40-8515210G) Includes: CHROME PLATED ZAMAC		
Panel Hardware Kit (P/N 40-8265211G) Includes: STAINLESS STEEL		
PART ID.	DESCRIPTION	QTY
6	 One Ear Wall Bracket	(2)
3	 Vandal Resistant 2 1/2" S.M.S	(4)
4	 Plastic Shields	(4)
5	 Vandal Resistant 5/8" S.M.S	(8)

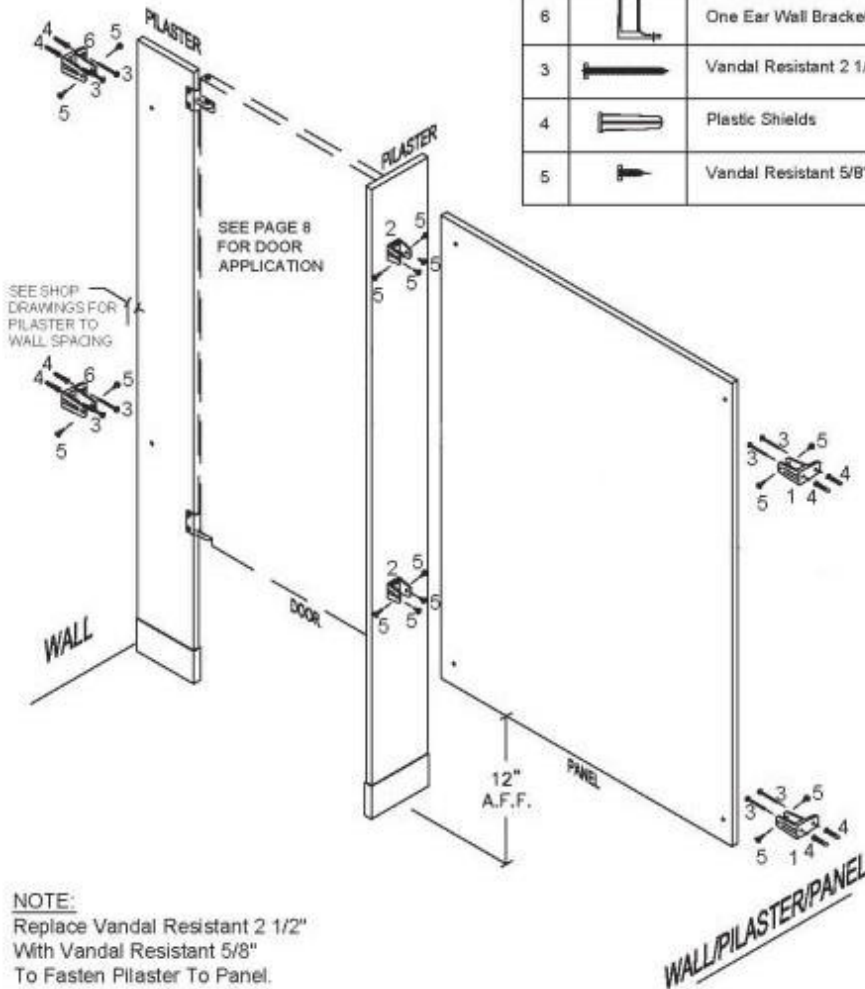

NOTE:  
Replace Vandal Resistant 2 1/2"  
With Vandal Resistant 5/8"  
To Fasten Pilaster To Panel.

## STEP 1 LAYOUT CEILING HUNG

- A. Review the layout drawings and package lists that have accompanied this job.
- B. Top of the finished ceiling and bottom edge of structural support should not exceed 1".
- C. Before proceeding, confirm that backing of wall and ceiling support is adequate to secure mounting of toilet compartment units.
- D. Confirm correct location and condition of threaded ceiling rods. These should project 2" to 2-1/2" below finished ceiling.
- E. Establish and mark pilaster and panel center lines in relation to ceiling rod locations and drawings. Bolts will be located 1" from edge of pilaster
- F. Mark wall bracket holes using brackets as templates.

**FIGURE 1**

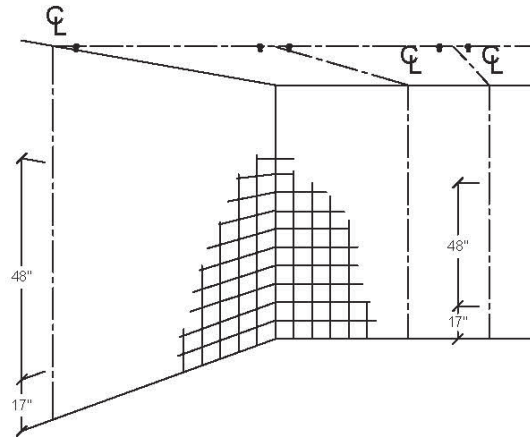

## STEP 2 WALL BRACKETS

- A. Drill holes for wall brackets of appropriate size for particular fastening devices supplied. Typically 1/4" drill bits can be used throughout.
- B. Insert anchoring devices in walls and secure wall brackets.
- C. Pilaster at wall should be prepared for wall and ceiling fastening as required by compartment layout.

**FIGURE 2**

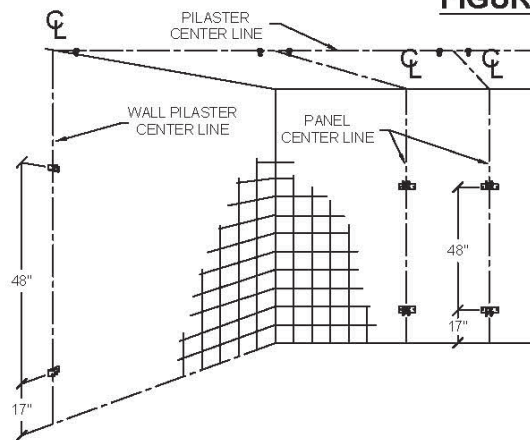

## STEP 3 POSITION PANEL

- A. Place panel on a support, 12" above the floor.
- B. Set it into wall brackets, but do not fasten panel at this time as it may need to be raised or lowered to sit flush with pilaster bottoms.

**FIGURE 3**

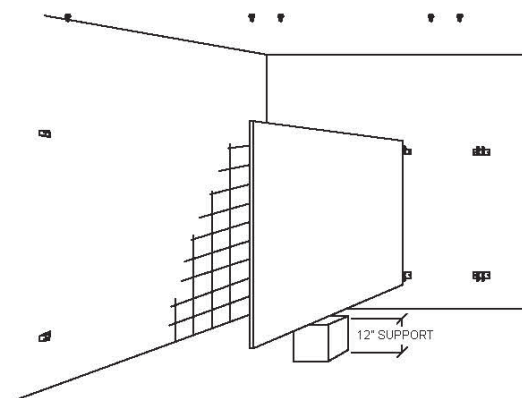

## STEP 4 PILASTER PREPARATION

- A. Align U-brackets in position on rear of pilasters. Refer to layout drawings.
- B. Fasten U-brackets to pilaster with sheet metal screws pre-drilling with 1/8" bit.
- C. Pilasters at wall do not require U-brackets.

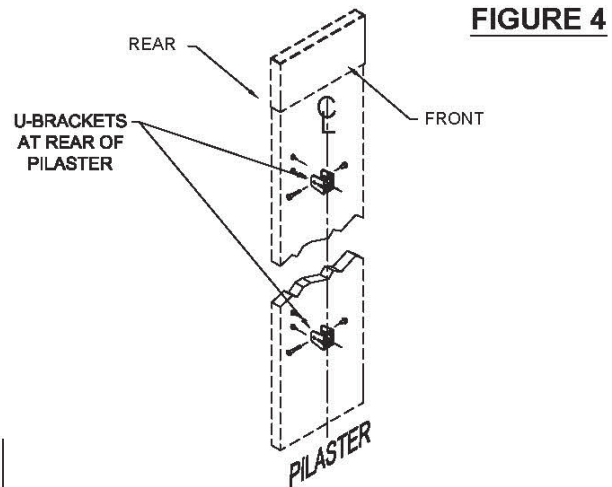

## STEP 5 INSTALL PILASTERS

NOTE: STRUCTURAL STEEL BY OTHERS

- A. Slide stainless steel shoe carefully over mounting end of pilaster and leave approximately 5" above bottom end.
- B. Thread support nuts and mounting washers over threaded rods to support pilaster mounting bar.
- C. Position pilaster and mounting channel on threaded rods and attach lightly with square flat washer, lockwasher and locking nut.

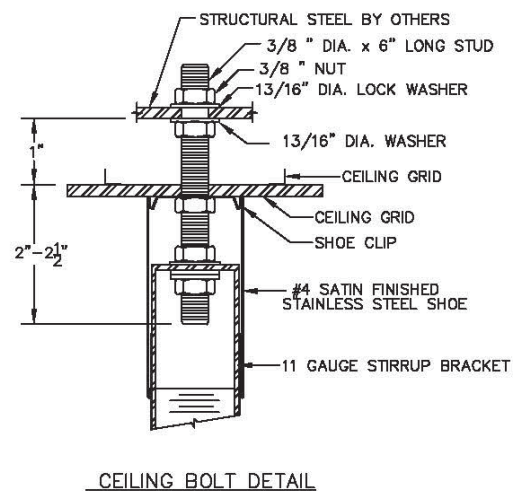

## STEP 6 SECURING PILASTERS TO PANELS

- A. Level each pilaster by adjusting both support nuts to desired position.
- B. Plumb each pilaster and fasten the pilaster to panel using through bolts or sheet metal screws.
- C. Establish door openings by setting pilaster mounting channel to desired position on stud.
- D. Tighten locking nuts on top of pilaster mounting channel.
- E. Slide stainless steel shoe up to ceiling level, firmly engaging shoe clips.
- F. Fasten panel to wall brackets using through bolts.
- G. Remove panel support device.

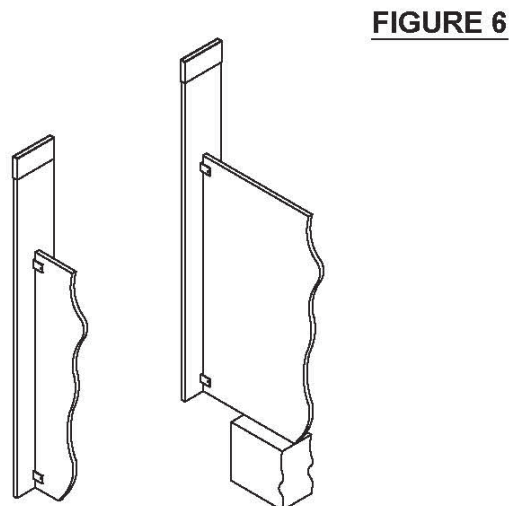





**CEILING HUNG  
PANEL TO PILASTER/WALL  
TWO EAR ASSEMBLY**

Fasten pilaster to panel using through bolts with barrel nuts or sheet metal screws.

Pilasters must be both plumb and level.  
(do not fasten at this time)

Establish bottom door openings by adjusting  
pilaster and tightening screws.(Refer to step 6)

Panel Hardware Kit (P/N 40-8515020G) Includes: CHROME PLATED ZAMAC		
Panel Hardware Kit (P/N 40-8265021G) Includes: STAINLESS STEEL		
PART ID.	DESCRIPTION	QTY
1	 Two Ear Bracket	(2)
2	 "U" Bracket	(2)
3	 Vandal Resistant 2 1/2" S.M.S	(4)
4	 Plastic Shields	(4)
5	 Vandal Resistant 5/8" S.M.S	(12)

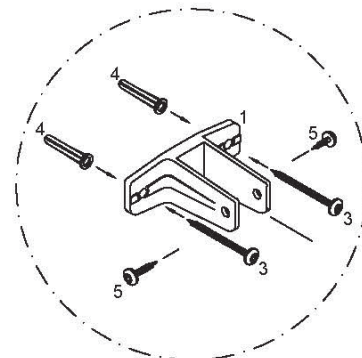
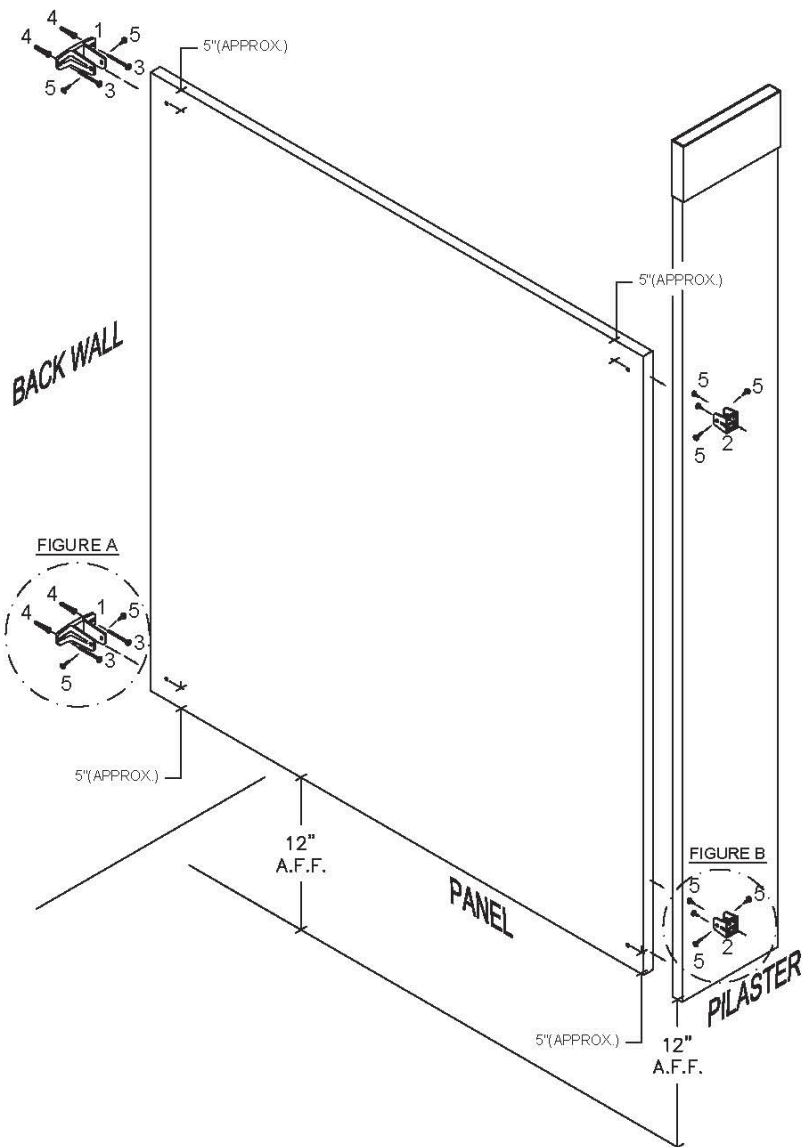

**FIGURE A**

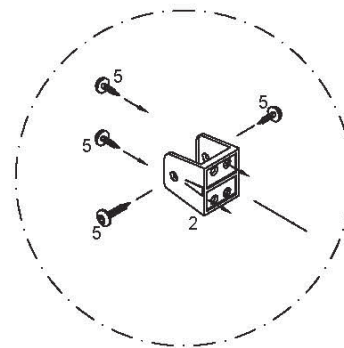

**NOTE:**  
Use Only Two  
Vandal resistant 5/8"SMS  
To Diagonally Fasten U-bracket To Pilaster.

**FIGURE B**

## CEILING HUNG PANEL TO PILASTER/WALL ONE EAR ASSEMBLY

Fasten pilaster to panel using sheet metal screws.

Pilasters must be both plumb and level.  
(do not fasten at this time)

Establish bottom door openings by adjusting pilaster and tightening screws.(Refer to step 6)

Panel Hardware Kit (P/N 40-8515010G) Includes: CHROME PLATED ZAMAC		
Panel Hardware Kit (P/N 40-8265011G) Includes: STAINLESS STEEL		
PART ID.	DESCRIPTION	QTY
1	 One Ear Bracket	(2)
2	 "U" Bracket	(2)
3	 Vandal Resistant 2 1/2" S.M.S.	(4)
4	 Plastic Shields	(4)
5	 Vandal Resistant 5/8" S.M.S.	(12)

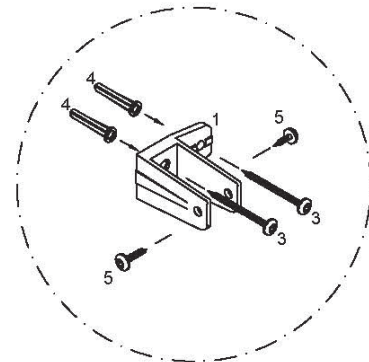
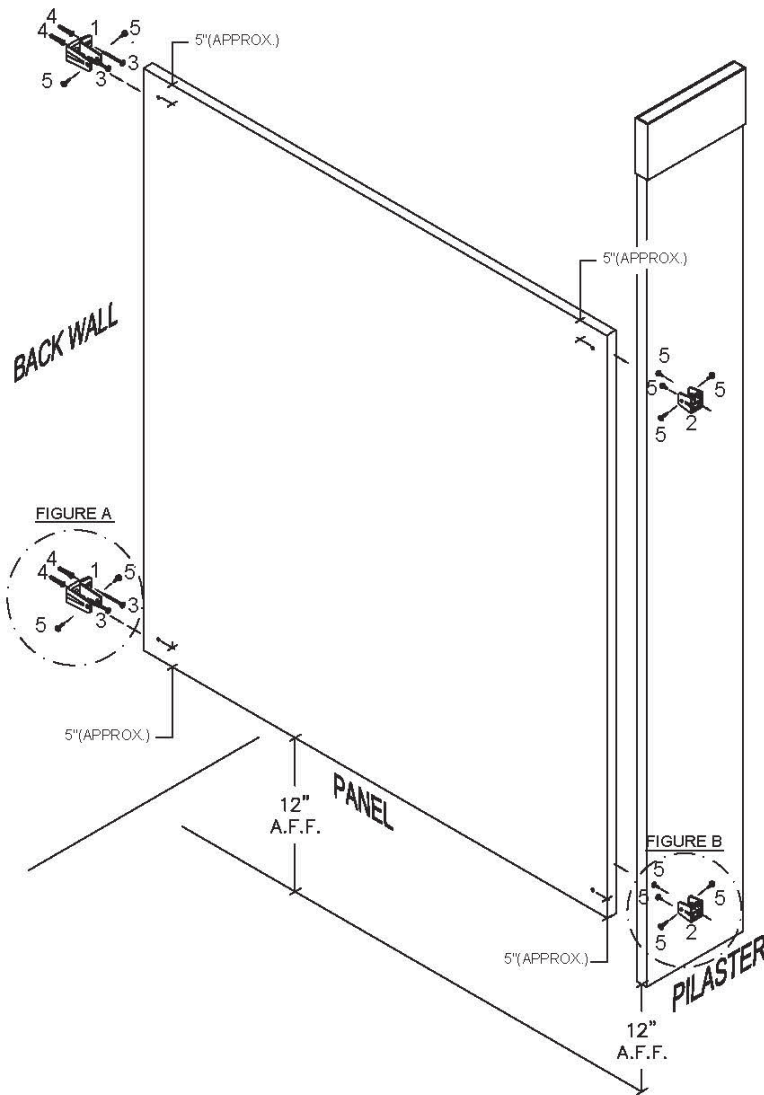
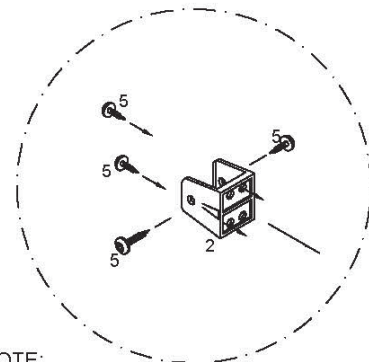

FIGURE A



**NOTE:**  
Use Only Two  
Vandal Resistant 5/8" SMS  
To Diagonally Fasten U-bracket To Pilaster.

FIGURE B



**CEILING HUNG  
PILASTER/WALL  
ASSEMBLY**

Pilasters must be both plumb and level.

Pilaster/Wall Hardware Kit (P/N 40-8515210G) Includes: CHROME PLATED ZAMAC		
Pilaster/Wall Hardware Kit (P/N 40-8265211G) Includes: STAINLESS STEEL		
PART ID.	DESCRIPTION	QTY
1	 One Ear Wall Bracket	(2)
2	 Vandal Resistant 2 1/2" S.M.S	(4)
3	 Plastic Shields	(4)
4	 Vandal Resistant 5/8" S.M.S	(8)

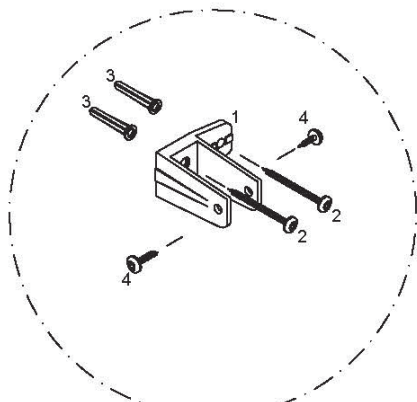
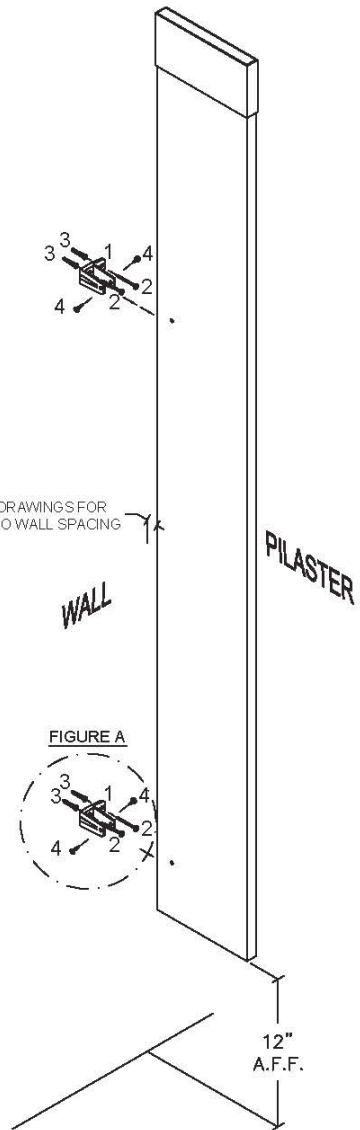

**FIGURE A**

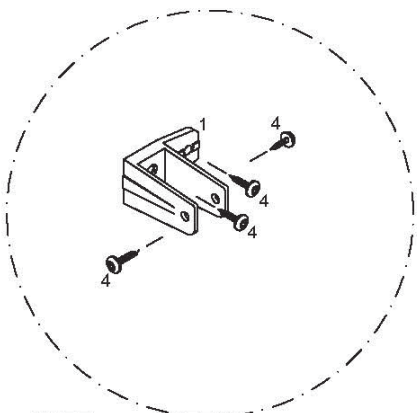

**NOTE:**  
Replace Vandal Resistantt 2 1/2" SMS  
With Vandal Resistant 5/8" SMS  
To Fasten Pilaster To Panel.



**CEILING HUNG  
PILASTER/PANEL ALCOVE  
ASSEMBLY**

Note:  
Replace P/N#40-8515010G with P/N#40-8515020G  
for two ear locations.

(P/N 40-8515010G) Includes: CHROME PLATED ZAMAC		(P/N 40-8265011G) Includes: STAINLESS STEEL	
PART ID.	DESCRIPTION	QTY	
1	 One Ear Bracket	(2)	
2	 "U" Bracket	(2)	
3	 Vandal Resistant 2 1/2" S.M.S	(4)	
4	 Plastic Shields	(4)	
5	 Vandal Resistant 5/8" S.M.S	(12)	

(P/N 40-8515210G) Includes: CHROME PLATED ZAMAC		(P/N 40-8265211G) Includes: STAINLESS STEEL	
PART ID.	DESCRIPTION	QTY	
6	 One Ear Wall Bracket	(2)	
3	 Vandal Resistant 2 1/2" S.M.S	(4)	
4	 Plastic Shields	(4)	
5	 Vandal Resistant 5/8" S.M.S	(8)	

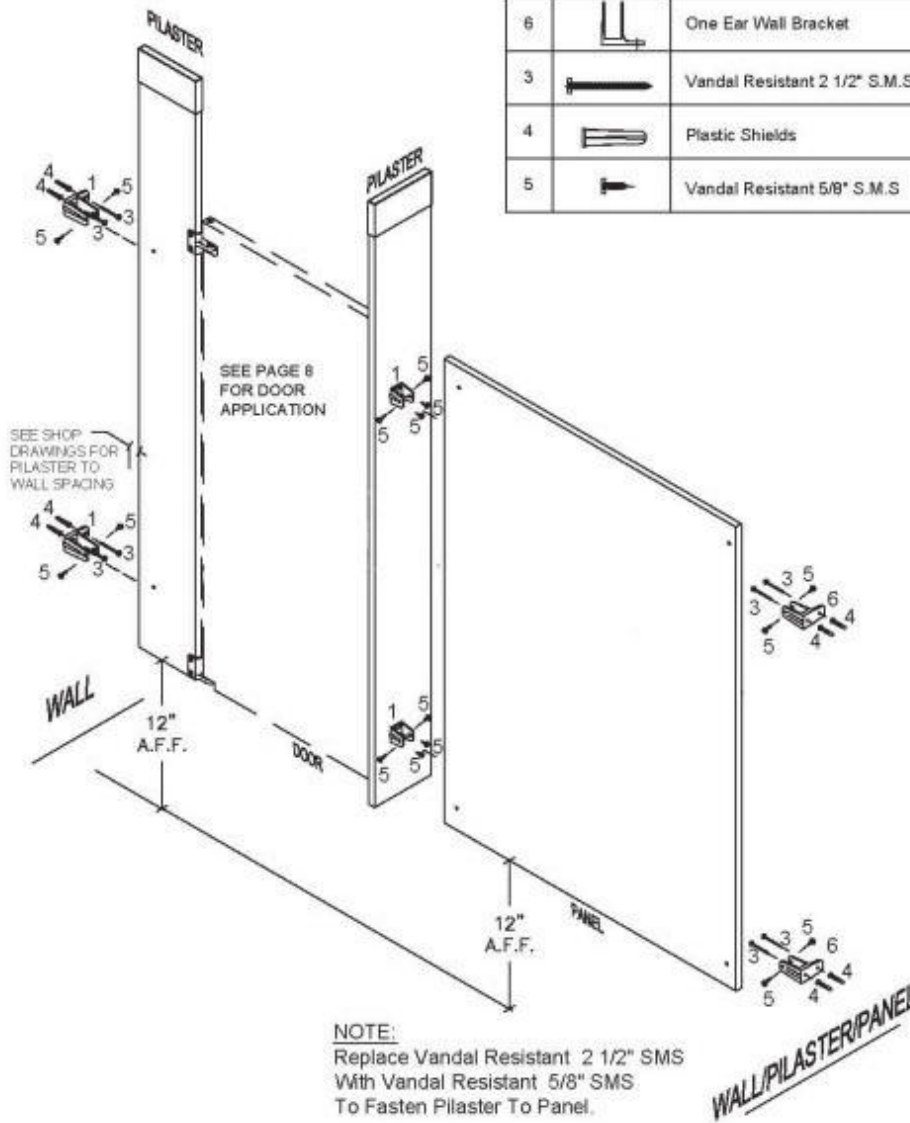

**STEP 1**  
**LAYOUT**  
**FLOOR AND CEILING ANCHORED**

- A. Review the layout drawings and package lists that have accompanied this job.
- B. Before proceeding, confirm that backing of walls and floor is adequate to support secure mounting of the toilet compartment units.
- C. Establish and mark pilaster center line from back wall.
- D. Establish and mark panel center lines for wall brackets.
- E. Establish pilaster floor and ceiling fastener locations from side wall according to shop drawings. (Note fasteners are located roughly 1" from lockstrip edge of pilaster.)
- F. Mark wall bracket holes using brackets as templates.

**FIGURE 1**

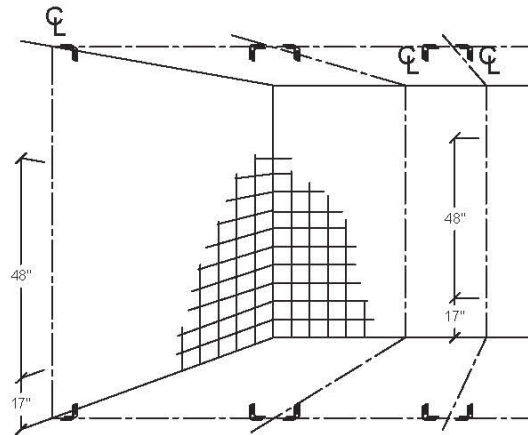

**STEP 2**  
**WALL BRACKETS AND FLOOR BRACKETS**

- A. Drill holes for wall brackets and floor fastenings of appropriate size for particular fastening devices supplied. Typically 1/4" drill bits can be used throughout.
  - B. Insert anchoring devices in walls and secure wall brackets.
  - C. Insert anchors and ceiling bolts.  
Position shoe clips and "L" brackets.  
Details in STEP 5.
- (Note ceiling "L" brackets engraved for identification)

**FIGURE 2**

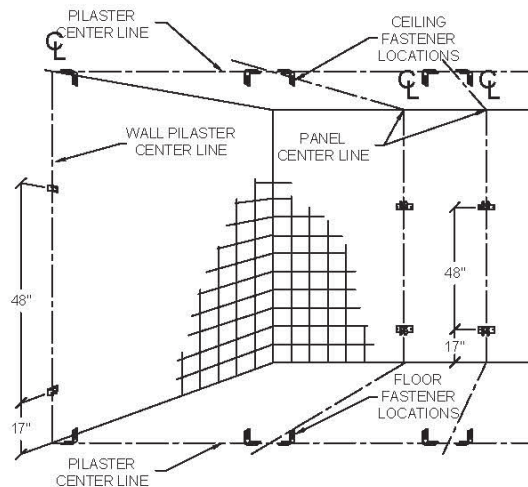

**STEP 3**  
**POSITION PANEL**

- A. Place panel on a support, 12" above the floor.
- B. Set it into wall brackets, but do not fasten panel at this time.

**FIGURE 3**

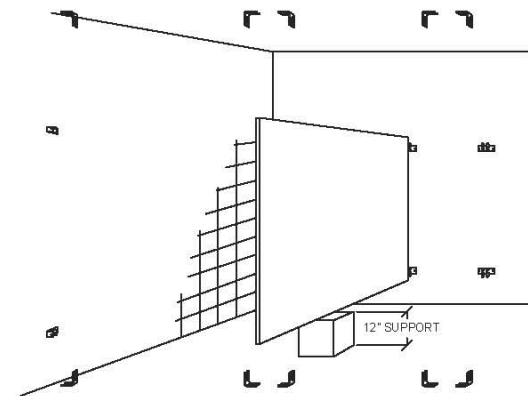

## STEP 4 PILASTER PREPARATION

- Align U-brackets in position on rear of pilasters. Refer to layout drawings.
- Fasten U-brackets to pilaster with sheet metal screws.
- Pilasters at wall do not require U-brackets, but should be prepared for wall (floor & ceiling fastening) as required by compartment layout.

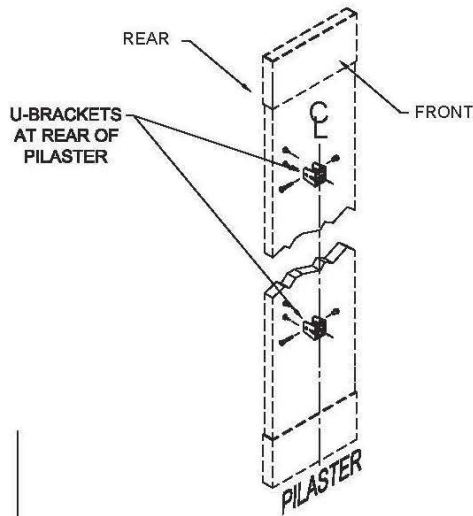

**FIGURE 4**

## STEP 5 INSTALL PILASTERS

### NOTE

Structural steel should be 2 1/2" inches MAX from the bottom of the finished ceiling.

- Slide stainless steel shoes carefully over mounting ends of pilaster and leave approximately 5" space from end.

- Place pilaster between "L" brackets adjust jack leveling bolt and fasten loosely with screws at predrilled locations at each side.

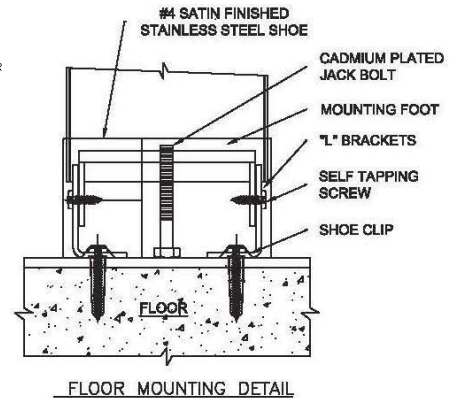
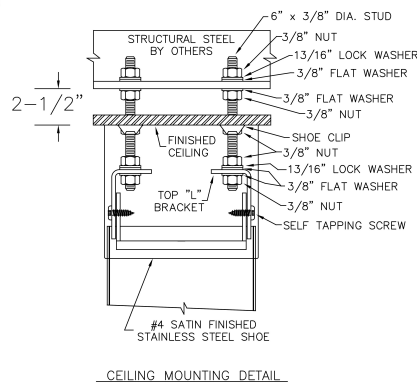

**FIGURE 5**

## STEP 6 SECURING PILASTERS TO PANELS

- Plumb each pilaster by adjusting self tapping screws at top & bottom to desired position & tighten.
- Fasten the pilaster to panel using sheet metal screws.
- Establish door openings by setting pilaster to desired position. (Refer to layout drawings)
- Slide stainless steel shoe up to ceiling level & down to floor level, firmly engaging shoe clips.
- Fasten panel to wall brackets using sheet metal screws.
- Remove panel support device.

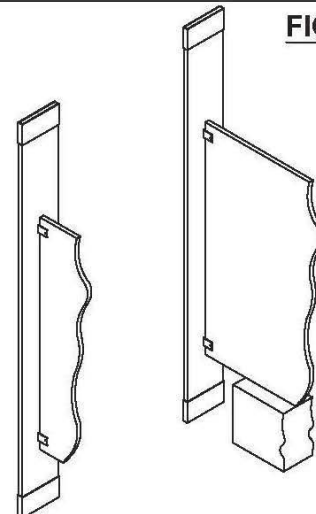

**FIGURE 6**

**FLOOR AND CEILING ANCHORED  
PANEL TO PILASTER/WALL  
TWO EAR ASSEMBLY**

Fasten pilaster to panel using sheet metal screws.

Pilasters must be both plumb and level.  
(do not fasten at this time)

Establish bottom door openings by adjusting  
pilaster and tightening screws.(Refer to step 6)

Panel Hardware Kit (P/N 40-8515020G) Includes: CHROME PLATED ZAMAC			
Panel Hardware Kit (P/N 40-8265021G) Includes: STAINLESS STEEL			
PART ID.		DESCRIPTION	QTY
1		Two Ear Bracket	(2)
2		"U" Bracket	(2)
3		Vandal Resistant C/P 2 1/2" S.M.S	(4)
4		Plastic Shields	(4)
5		Vandal Resistant C/P 5/8" S.M.S	(12)

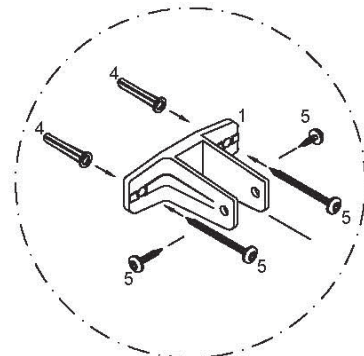
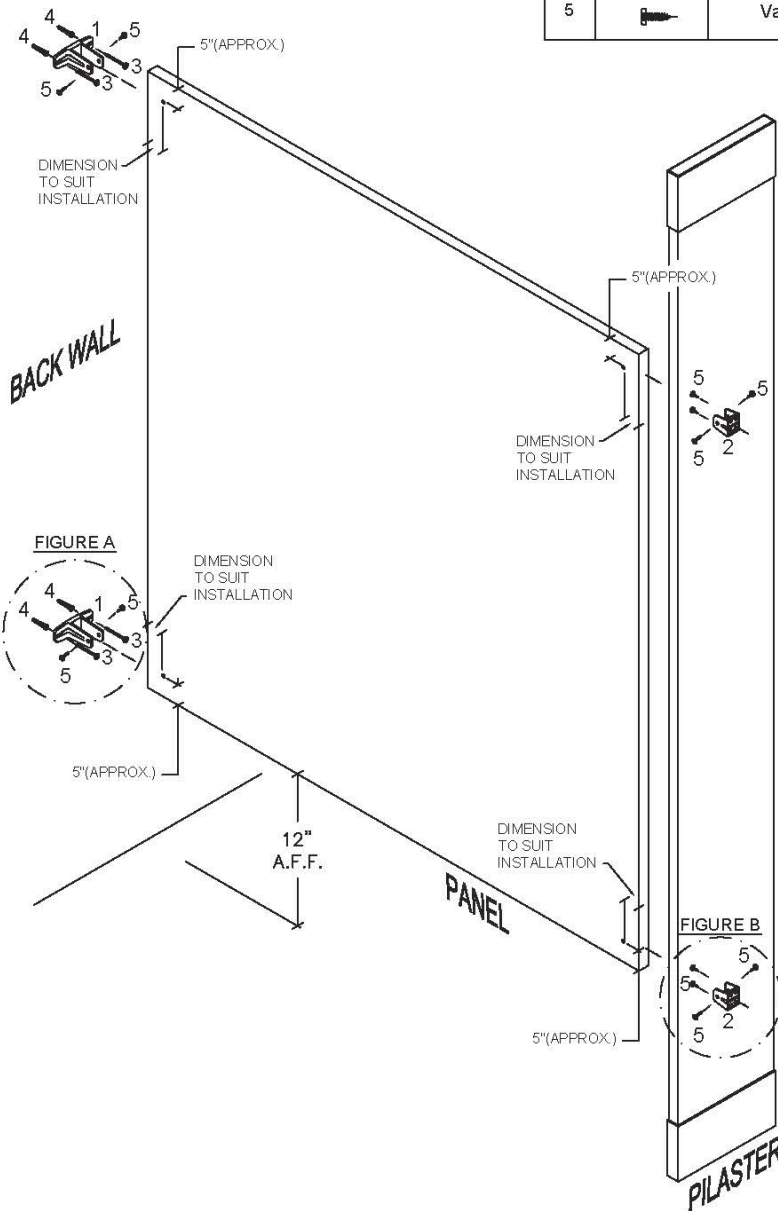

**FIGURE A**

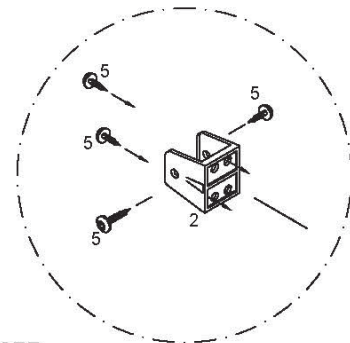

**FIGURE B**

**NOTE:**  
Use Only Two  
Vandal Resistant 5/8" SMS  
To Diagonally Fasten U-bracket To Pilaster.







## FLOOR AND CEILING ANCHORED PANEL TO PILASTER/WALL ONE EAR ASSEMBLY

Fasten pilaster to panel using sheet metal screws.

Pilasters must be both plumb and level.  
(do not fasten at this time)

Establish bottom door openings by adjusting  
pilaster and tightening screws.(Refer to step 6)

Panel Hardware Kit (P/N 40-8515010G) Includes: CHROME PLATED ZAMAC		
Panel Hardware Kit (P/N 40-8265011G) Includes: STAINLESS STEEL		
PART ID.	DESCRIPTION	QTY
1	 One Ear Bracket	(2)
2	 "U" Bracket	(2)
3	 Vandal Resistant 2 1/2" S.M.S	(4)
4	 Plastic Shields	(4)
5	 Vandal Resistant 5/8" S.M.S	(12)

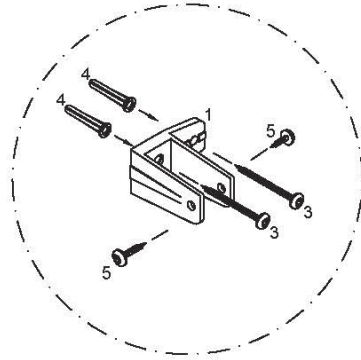
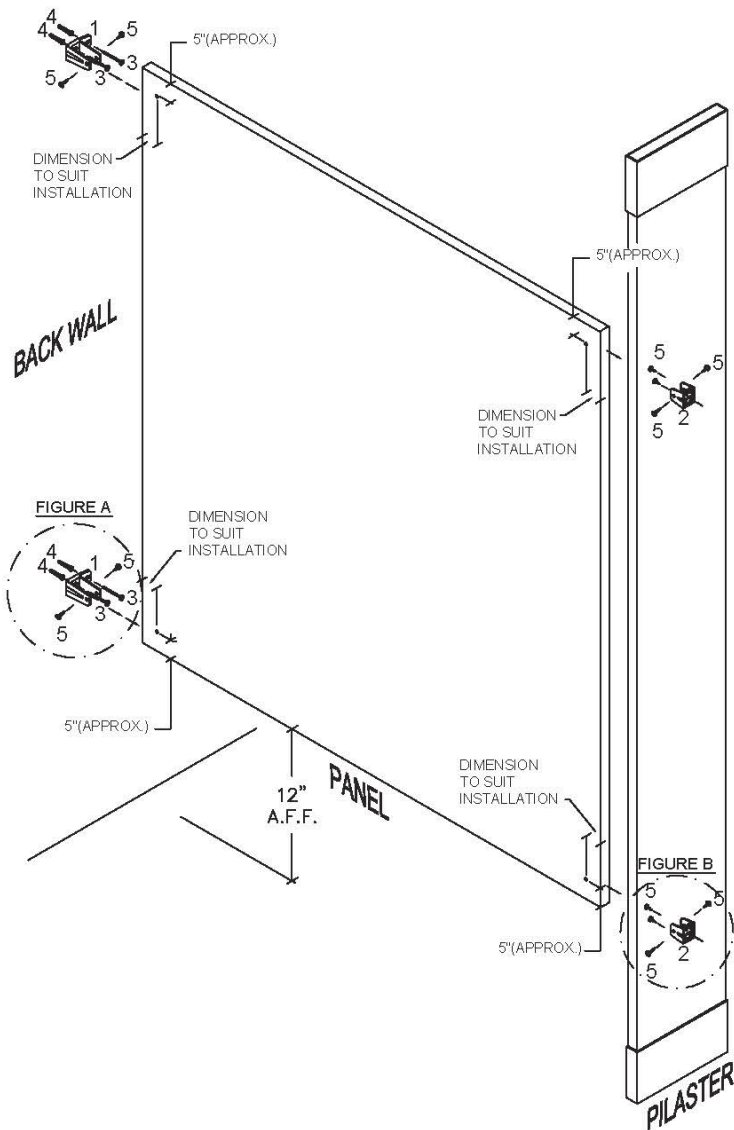

FIGURE A

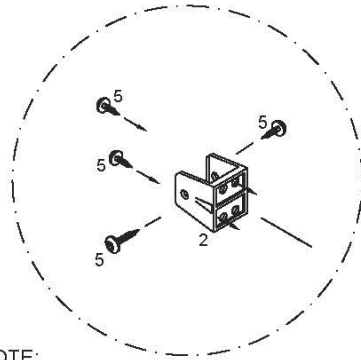

FIGURE B

**NOTE:**  
Use Only Two Vandal Resistant 5/8"  
To Diagonally Fasten U-bracket To Pilaster.

## FLOOR AND CEILING ANCHORED PILASTER/WALL ASSEMBLY

Fasten pilaster to panel using sheet metal screws.

Pilasters must be both plumb and level.  
(do not fasten at this time)

Establish bottom door openings by adjusting  
pilaster and tightening screws.(Refer to step 6)

Pilaster/Wall Hardware Kit (P/N 40-8515210G) Includes: CHROME PLATED ZAMAC			
Pilaster/Wall Hardware Kit (P/N 40-8265211G) Includes: STAINLESS STEEL			
PART ID.		DESCRIPTION	QTY
1		One Ear Wall Bracket	(2)
2		Vandal Resistant 2 1/2" S.M.S	(4)
3		Plastic Shields	(4)
4		Vandal Resistant 5/8" S.M.S	(8)

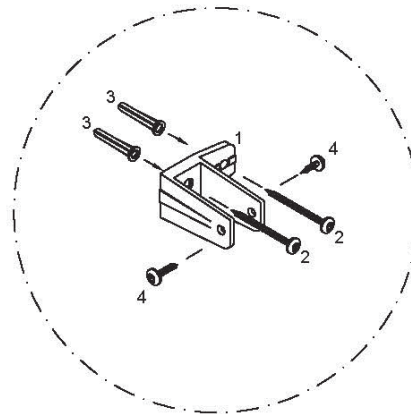
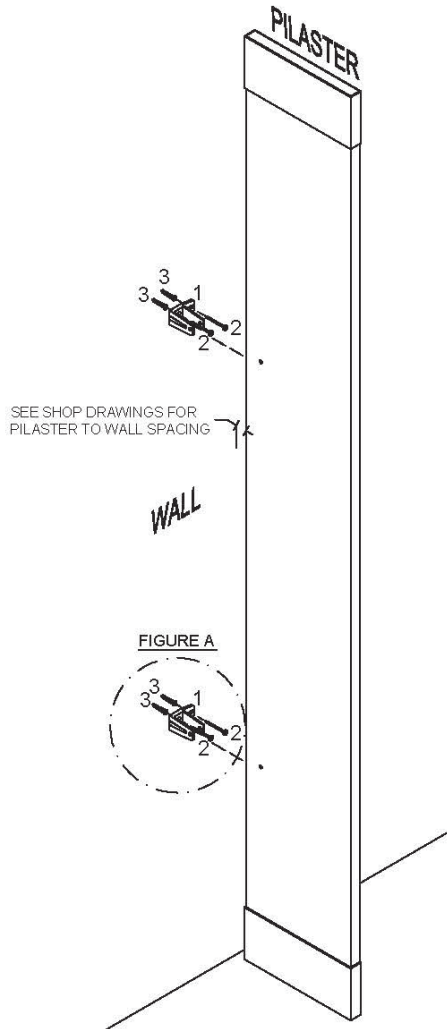

**FIGURE A**

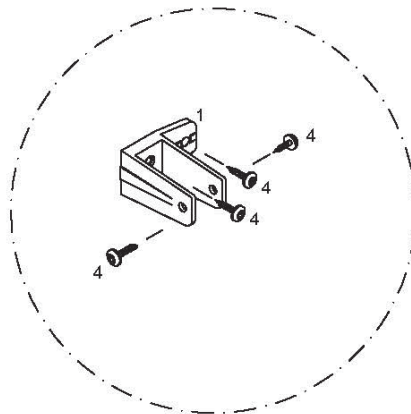

**ALTERNATE**

**NOTE:**  
Replace vandal Resistant 2 1/2" SMS  
With Tamper Resistant 5/8" SMS  
To Fasten Pilaster To Panel.



## FLOOR AND CEILING ANCHORED PILASTER/PANEL ALCOVE ASSEMBLY

NOTE: Use 40-8517320 for two ear alcove.

Alcove Hardware Kit (P/N 40-8517310G) Includes: CHROME PLATED ZAMAC		
Alcove Hardware Kit (P/N 40-8267311G) Includes: STAINLESS STEEL		
PART ID.	DESCRIPTION	QTY
1	1 1/4" One Ear Wall Bracket	(2)
2	Vandal Resistant 2 1/2" S.M.S	(10)
3	Plastic Shields	(10)
4	Vandal Resistant 5/8" S.M.S	(14)
5	Alcove Clip	(2)
6	1" One Ear Wall Bracket	(2)
7	Vandal Resistant 1" S.M.S	(4)
8	Bracket Headrail Salin 1/2" Zamac (NOT USED FOR FTC)	(1)

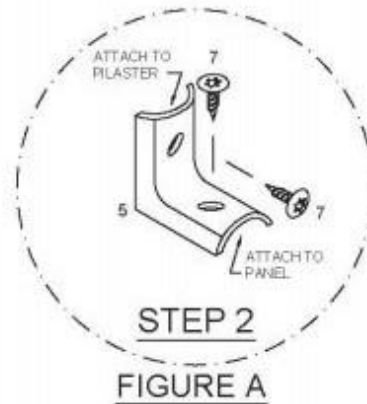
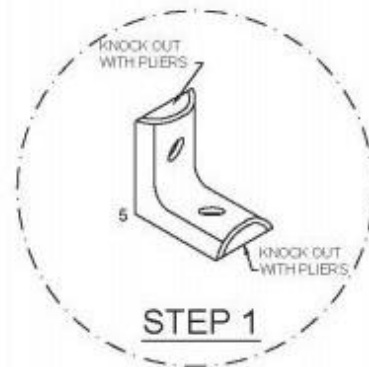
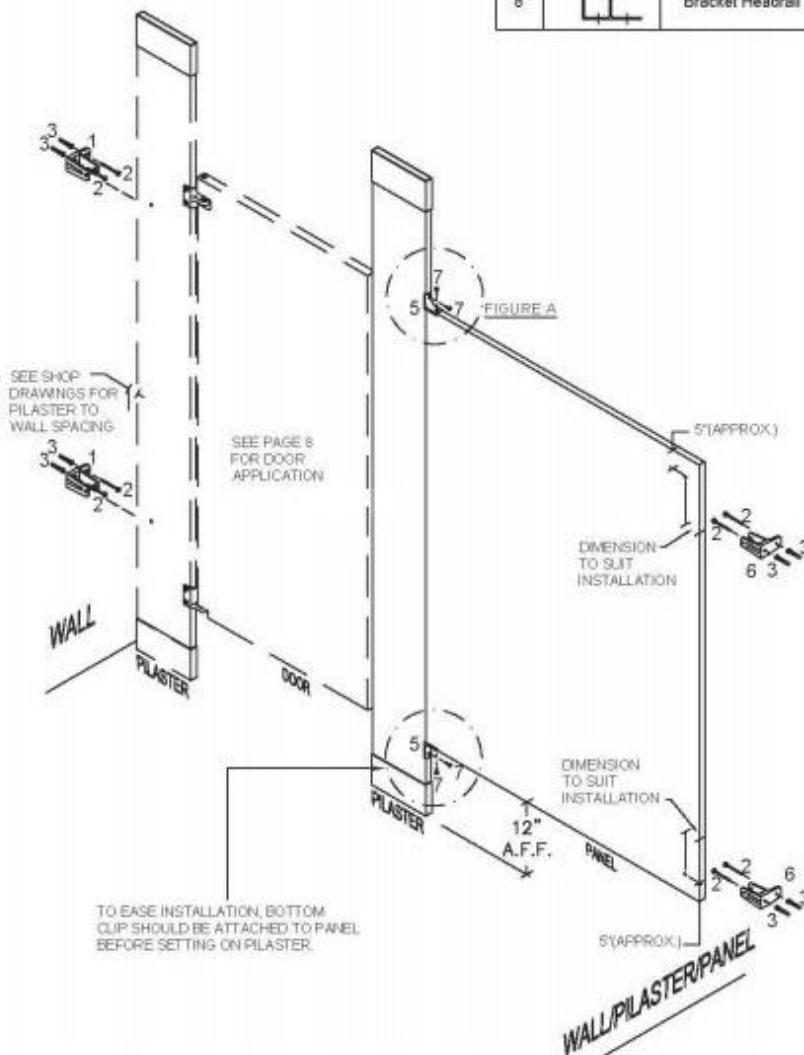

**FLOOR AND CEILING ANCHORED  
PILASTER/PANEL/PILASTER INLINE  
ASSEMBLY**

Alcove Hardware Kit (P/N 8517030) Includes: CHROME PLATED ZAMAC			
PART ID.		DESCRIPTION	QTY
1		Alcove Clips	(12)
2		Vandal Resistant Step Bolts 1" Long	(12)
3		Vandal Resistant Barrel Nut	(12)
4		Vandal Resistant 5/8" S.M.S	(12)

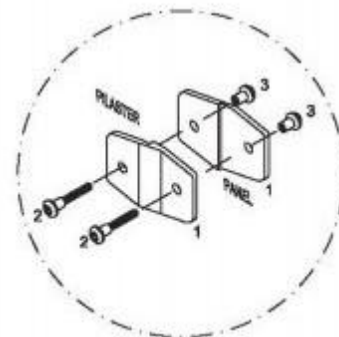
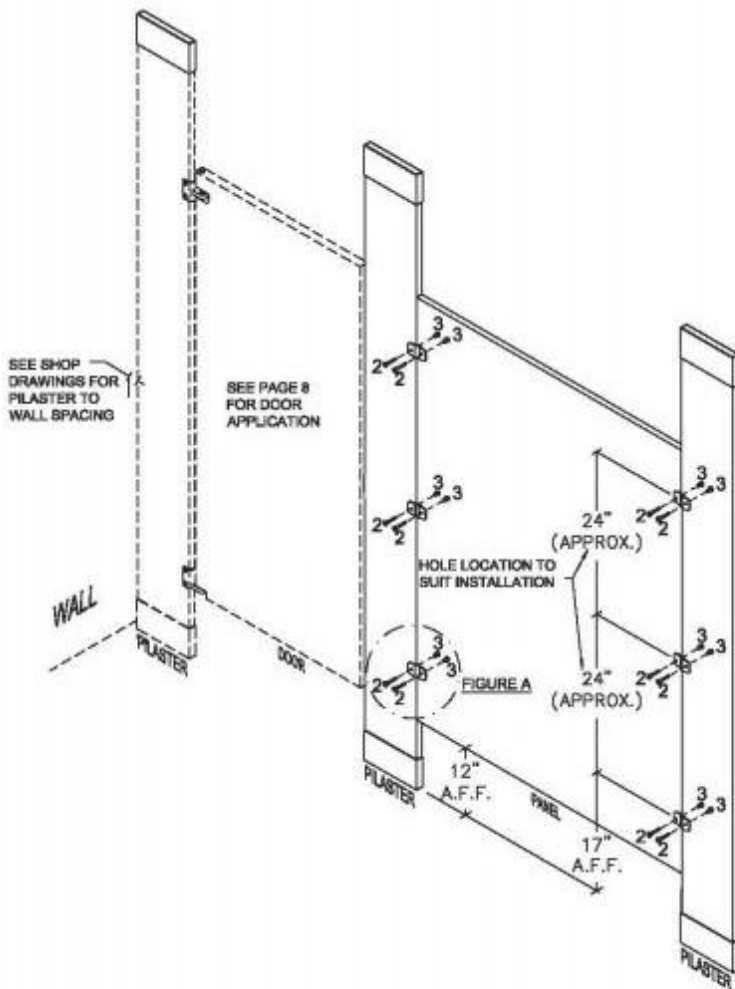

**FIGURE A**

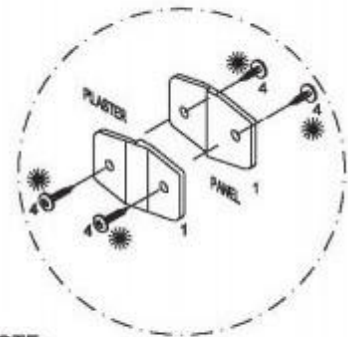







**NOTE:**  
Offset brackets for screw clearance

**OPTIONAL**

**OPTIONAL**  
Two Vandal Resistant 5/8" SMS  
May be Used (But Not Recommended)  
To Fasten brackets To Panel.

**NOTE:**  
Replace Vandal Resistant 2 1/2" SMS  
With Vandal Resistant 5/8" SMS  
To Fasten Pilaster To Panel.





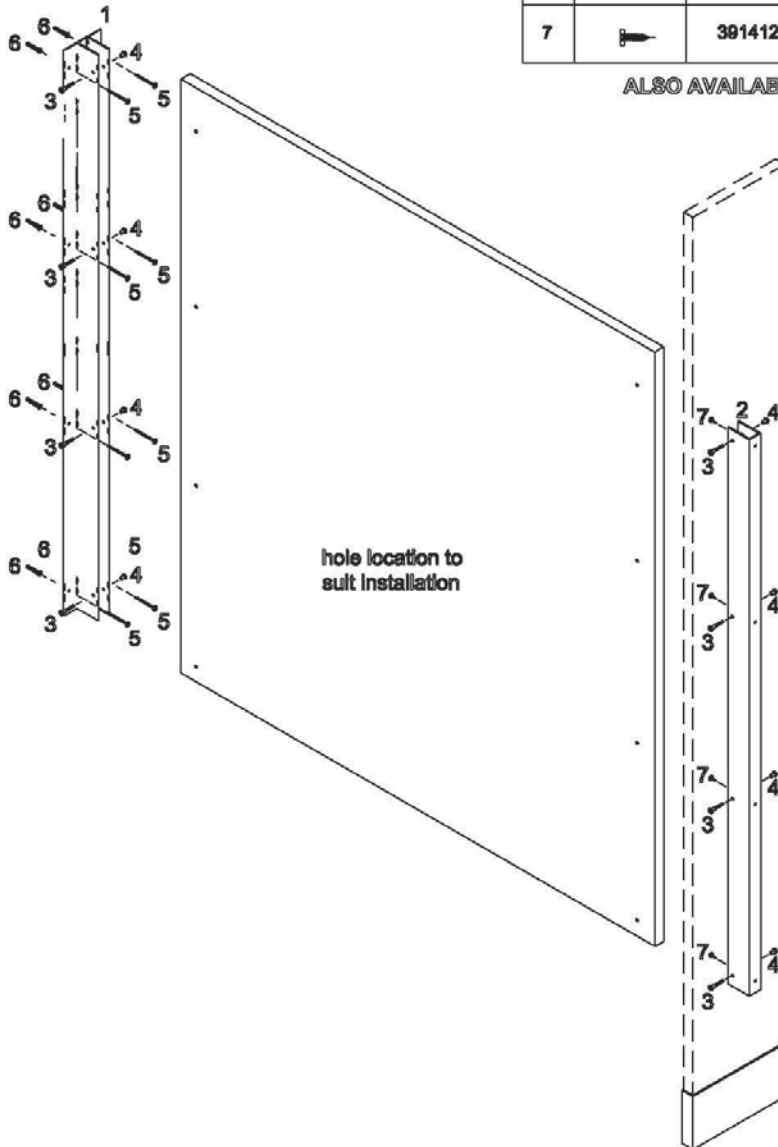

**OPTIONAL FULL HEIGHT  
PANEL TO PILASTER/WALL  
TWO EAR ASSEMBLY**

Panel Hardware Kit (P/N 8448020) Includes: ALUMINUM FULL HEIGHT		
PART ID.	DESCRIPTION	QTY
1	 5442750 Two Ear Bracket	(1)
2	 5448540 "U" Bracket	(1)
3	 3910600 Theft Resistant C/P Step Bolts 1" Long	(12)
4	 3910690 Theft Resistant C/P Barrel Nut	(12)
5	 3910450 Theft Resistant C/P #14 x 2 1/2" S.M.S	(12)
6	 3080000 Plastic Shields	(12)
7	 3914120 Theft Resistant C/P #14 x 5/8" S.M.S	(12)

ALSO AVAILABLE IN STAINLESS STEEL P/N 8286020







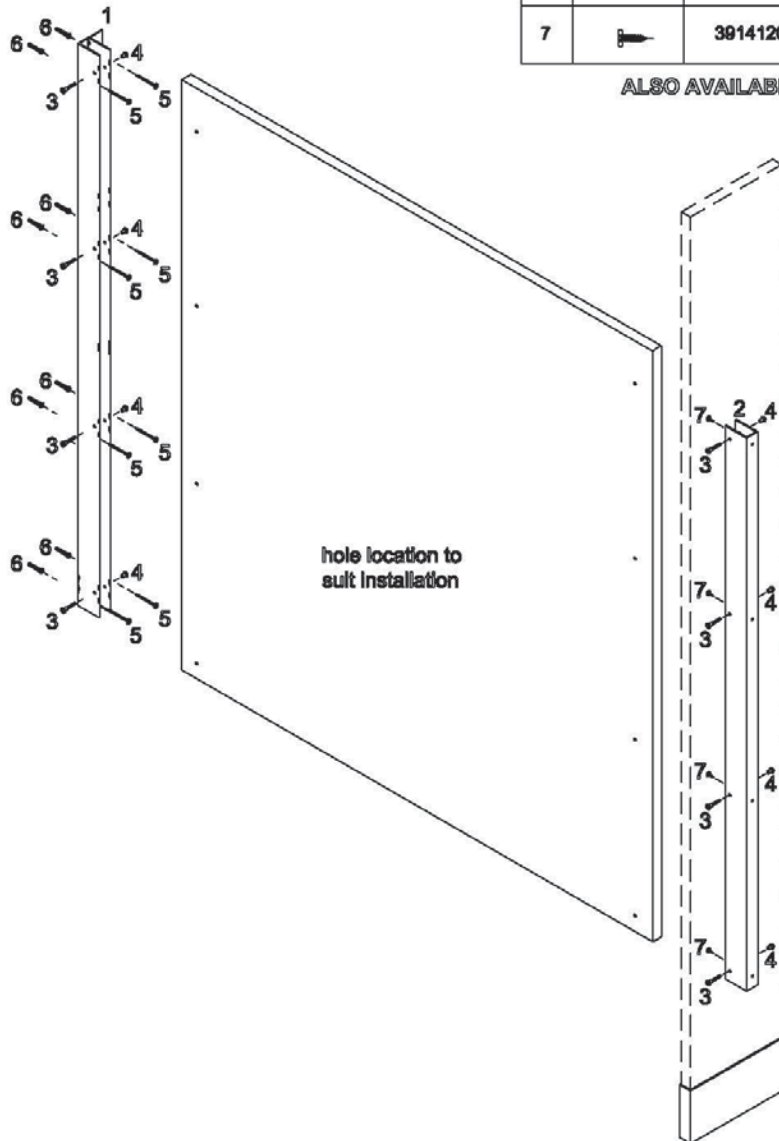

**OPTIONAL FULL HEIGHT  
PANEL TO PILASTER/WALL  
ONE EAR ASSEMBLY**

Panel Hardware Kit (P/N 8446010) Includes: ALUMINUM FULL HEIGHT			
PART ID.		DESCRIPTION	QTY
1		5442760 One Ear Bracket	(1)
2		5449540 "U" Bracket	(1)
3		3910600 Theft Resistant C/P Step Bolts 1" Long	(12)
4		3910690 Theft Resistant C/P Barrel Nut	(12)
5		3910450 Theft Resistant C/P #14 x 2 1/2" S.M.S	(12)
6		3080000 Plastic Shields	(12)
7		3914120 Theft Resistant C/P #14 x 5/8" S.M.S	(12)

ALSO AVAILABLE IN STAINLESS STEEL P/N 8266010



**OPTIONAL FULL HEIGHT  
PILASTER/WALL  
ASSEMBLY**

Pilaster/Wall Hardware Kit (P/N 8446210) includes: ALUMINUM FULL HEIGHT			
PART ID.		DESCRIPTION	QTY
1		5441840 One Ear Wall Bracket	(2)
2		3910700 Theft Resistant C/P Step Bolts 1 1/4" Long	(8)
3		3910890 Theft Resistant C/P Barrel Nut	(8)
4		3910450 Theft Resistant C/P #14 x 2 1/2" S.M.S	(12)
5		3080000 Plastic Shields	(12)
6		3914120 Theft Resistant C/P #14 x 5/8" S.M.S	(8)



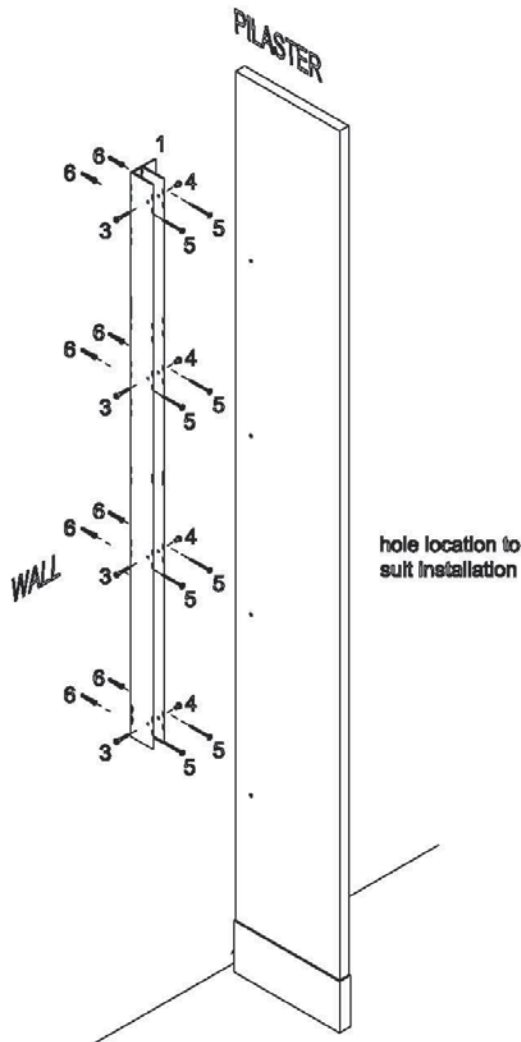

ALSO AVAILABLE IN STAINLESS STEEL P/N 6266210





**OPTIONAL FULL HEIGHT  
URINAL SCREEN  
ASSEMBLY**

- A. Before proceeding, confirm that backing of wall is adequate to support and secure mounting of urinal screens.
- B. Insert anchoring devices in walls and secure wall brackets.
- C. Place urinal screen on a support, 12" above the floor.
- D. Set it into wall bracket and fasten urinal screen at this time.

Urinal Screen Hardware Kit (P/N 8449000) Includes: ALUMINUM FULL HEIGHT			
PART ID.		DESCRIPTION	QTY
1		5449000 36" Long Two Ear Wall U/S Bracket	(1)
2		3910450 Theft Resistant C/P #14 x 2 1/2" S.M.S	(8)
3		3080000 Plastic Shields	(8)
4		3910600 Theft Resistant C/P Step Bolts 1" Long	(4)
5		3910690 Theft Resistant C/P Barrel Nut	(4)

ALSO AVAILABLE IN STAINLESS STEEL P/N 8269000

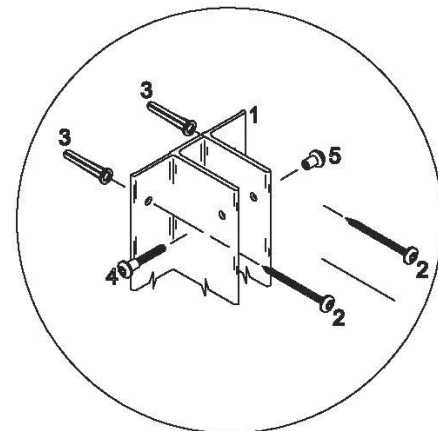
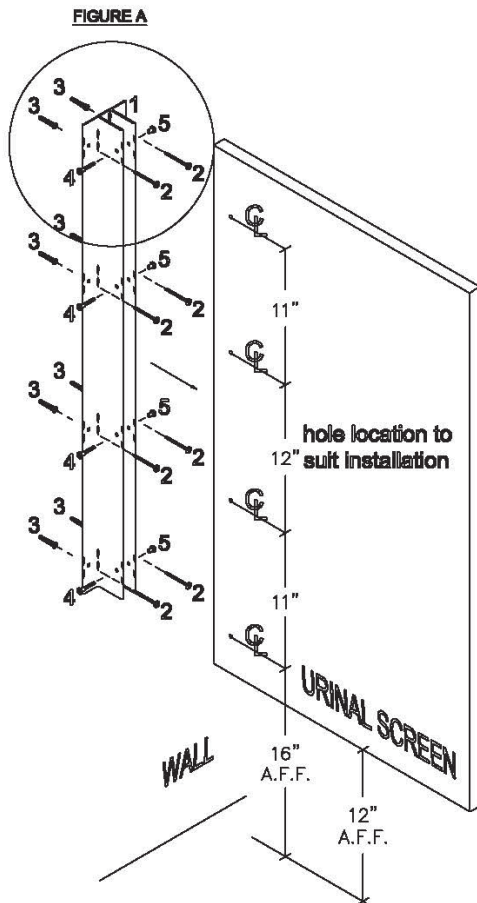

**FIGURE A**

**CARE AND MAINTENANCE OF  
TOILET PARTITIONS**

In order to provide toilet partitions with the care and maintenance, the following instructions must be followed.

- A. All surfaces must be kept clean with water and mild soap solution only.
- B. In high humidity areas, the rooms must be properly ventilated.
- C. "Hosing down" or wet washing of these units may cause water absorption and damage
- D. For maximum protection, periodic application of any standard furniture wax will be beneficial.
- E. In order to provide toilet partitions with the proper care and maintenance, the above instructions must be followed.

**WARNING**

Under no circumstances should the components be subjected to:

- \* Abrasive powders or pads
- \* Water closet cleaners
- \* Ceramic tile cleaners
- \* Solutions containing more than 1% by volume of ammonia
- \* Solutions containing acids or lye
- \* Solutions containing enzymes

Attention to work progress during new construction or renovation is important.

Other trades and cleaning services may use agents for ceramics and tiles that will damage these components.